

Q'nique19 X

Instruction Manual



Important Safety Instructions

When using an electrical appliance, basic safety precautions should always be followed, including the following.

DANGER - To reduce the risk of electric shock, do not leave the machine unattended when plugged in. Always unplug this machine from the electric outlet immediately after using and before cleaning.

WARNING - To reduce the risk of burns, fire, electric shock, or injury to persons:

- This appliance is not intended for use by persons (including children) with reduced physical, sensory or mental capabilities, or lack of experience and knowledge, unless they have been given supervision or instruction concerning use of the appliance by a person responsible for their safety.
- Children should be supervised to ensure that they do not play with the appliance.
- Use this machine only for its intended use as described in this manual. Use only attachments recommended by the manufacturer as contained within this manual.
- Never operate this machine if it has a damaged cord or plug, it is not working properly, or it has been dropped, damaged, or dropped into water. Return the machine to the nearest authorized dealer or service center for examination, repair, or electrical or mechanical adjustment.
- Never operate the machine with any air openings blocked. Keep ventilation openings of the quilting machine free from the accumulation of lint, dust, and loose cloth.
- Never drop or insert any object into any opening.
- Do not use outdoors.
- Do not operate where aerosol (spray) products are being used or where oxygen is being administered.
- Connect this appliance to a properly grounded outlet only. See grounding instructions on next page.
- To disconnect, turn all controls to the off position, then remove the plug from the outlet by grasping the plug. Do not pull on cord.
- Do not unplug by pulling on cord. To unplug, grasp the plug, not the cord.
- If the supply cord is damaged, it must be replaced by the manufacturer, its service agent or similarly qualified persons in order to avoid a hazard.
- Keep fingers away from all moving parts. Special care is required around the quilting machine needle.
- Always use the proper needle plate. The wrong plate can cause the needle to break.
- Do not use bent or damaged needles.
- Do not pull or push fabric while stitching. It may deflect the needle, causing it to break.
- Switch the quilting machine off when making any adjustments in the needle area, such as threading the needle, changing the needle, or changing the presser foot, etc.
- Always unplug the quilting machine from the electrical outlet when removing covers, lubricating, or when making any other user servicing adjustments mentioned in the instruction manual.
- **CAUTION:** In order to avoid a hazard due to inadvertent resetting of the thermal cut-out, this appliance must not be supplied through an external switching device, such as a timer, or connected to a circuit that is regularly switched on and off by the utility.

If using this machine in an area with inconsistent input power, it is recommended the surge protector is connected to a backup battery supply.

SAVE THESE INSTRUCTIONS

Do not discard box or packaging

GROUNDING INSTRUCTIONS

This product must be grounded. In the event of malfunction or breakdown, grounding provides a path of least resistance for electric current to reduce the risk of electric shock. This product is equipped with a cord that has an equipment-grounding conductor and a grounding plug. Plug the cord from the quilting machine into a surge protector. The surge protector must be plugged into an appropriate outlet that is properly installed and grounded in accordance with all local codes and ordinances.

DANGER - Improper connection of the equipment-grounding conductor can result in a risk of electric shock. The conductor with insulation having an outer surface that is green, with or without yellow stripes, is the equipment-grounding conductor. If repair or replacement of the cord or plug is necessary, do not connect the equipment-grounding conductor to a live terminal. Check with a qualified electrician or serviceman if the grounding instructions are not completely understood, or if in doubt as to whether the product is properly grounded.

Do not modify the plug provided with the product — if it will not fit the outlet, have a proper outlet installed by a qualified electrician.

Grounding Methods

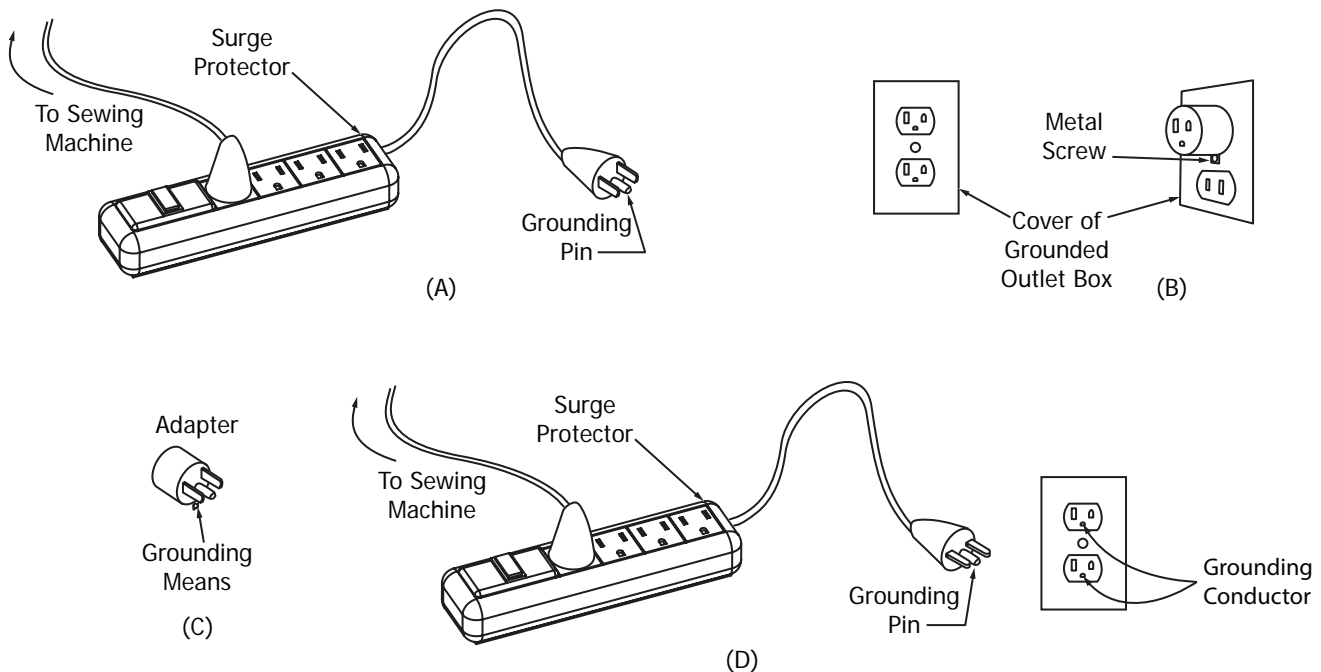

This product is for use on a nominal 120 V circuit, and has a grounding pin as illustrated above (A). A temporary adapter, shown in (B) and (C), may be used to connect this plug to a 2-pole receptacle (B) if a properly grounded outlet is not available. The temporary adapter should be used only until a properly grounded outlet can be installed by a qualified electrician. The green colored rigid ear, lug, and the like, extending from the adapter must be connected to a permanent ground such as a properly grounded outlet box cover. Whenever the adapter is used, it must be held in place by the metal screw.

A qualified electrician should be consulted if there is any doubt as to whether an outlet box is properly grounded.

Table of Contents

Important Safety Instructions	i	Maintaining the Machine	67
Table of Contents.....	iii	Preparing the Oil Bottle	68
Machine Specifications	iv	Oiling and Cleaning.....	69
Machine Layout	v	Changing the Needle.....	73
Ports and Plugins.....	vii	Adjusting the Hopping Foot	75
My Machine Details.....	ix	Reinstalling the Needle Plate	80
Included Parts and Tools	x	Repairs and Diagnostics	82
Welcome to Your Q'nique 19X.....	1	Troubleshooting the Bobbin Wind.....	83
Animated Instructions	3	Replacing the Encoder Spring	85
Out-of-the Box Assembly	3	Reinstalling the Hook Holder.....	88
Part One	4	Timing the Machine	91
Task 1- Installing the Lower Encoder.....	5	Appendix.....	95
Part Two	10	Choosing Your Needle	96
Task 2 - Installing the Wheels.....	11	Choosing Your Thread.....	98
Part Three.....	16	Choosing Your Fabric and Batting.....	101
Task 3 - Installing the Wheel Base		Troubleshooting Guide	102
Covers	17	Index.....	104
Task 4 - Installing the Handlebars	19		
Task 5 - Connecting the Display.....	22		
Task 6 - Attaching the Thread Stand	24		
Task 7 - Installing the Upper Encoder.....	25		
Task 8 - Turning the Machine On/Off.....	27		
Preparing to Quilt	28		
Task 9 - Winding a Bobbin.....	29		
Task 10 - Loading the Bobbin Case	32		
Task 11 - Threading the Machine	34		
Part Four.....	40		
Quilting	41		
Choosing Machine Settings.....	42		
Using the Handlebar Controls	44		
Using Precise Quilting Mode	45		
Using Cruise Quilting Mode.....	47		
Using Manual Quilting Mode	49		
Using Baste Quilting Mode.....	51		
Screen Settings	53		
Using the Edge Warning.....	54		
Adjusting Thread Tension	57		
Taking Measurements	60		
System Info	62		
Getting Started.....	63		

Machine Specifications

Patent: WO 2013/070633 AI
Additional Patents Pending

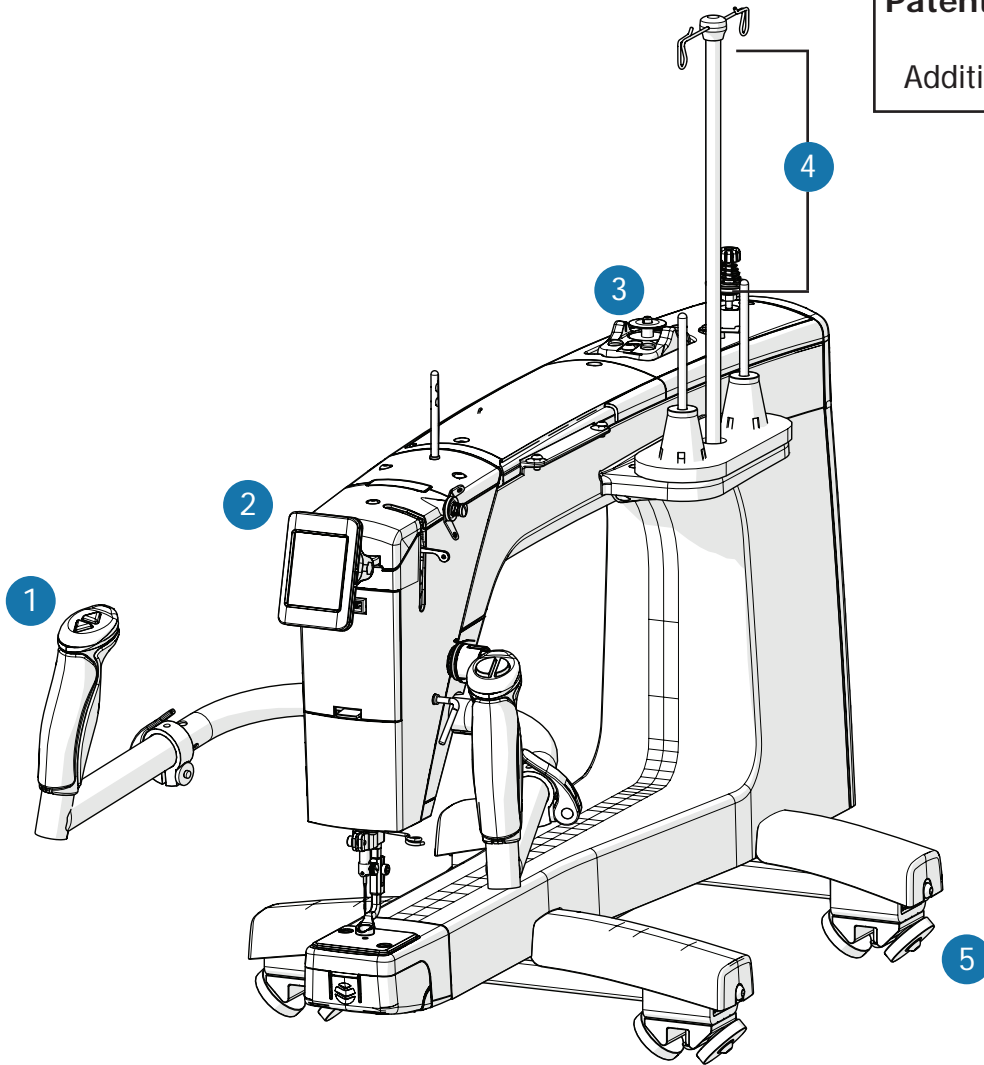

Product Dimensions

Body:

- Height: 680.2 mm, or 26.8 inches
- Width: 395.4 mm, or 15.6 inches
- Length: 831.9 mm, or 32.8 inches
- Weight: 18.8 kg, or 41.5 lbs

Quilting Arm:

- Height: 224.8 mm, or 8.9 inches
- Width: 482.6 mm, or 19 inches

Electrical

- Input Voltage: 110-220 VAC
- Peak Power Consumption: 300 W

Features

- 1 Ergonomic handles and handlebars for efficient, extended use (page 19)
- 2 2.4" Touch display (page 22)
- 3 Built in bobbin winder (page 29)
- 4 Dual thread mast and stands for quilting and winding bobbin at the same time
- 5 Dual wheels for added stability (page 5)
- Edge Warning System (page 54)
- Range of 90 to 2000 stitches per minute
- Regulated stitching

Machine Layout

Quilting Machine (Side View)

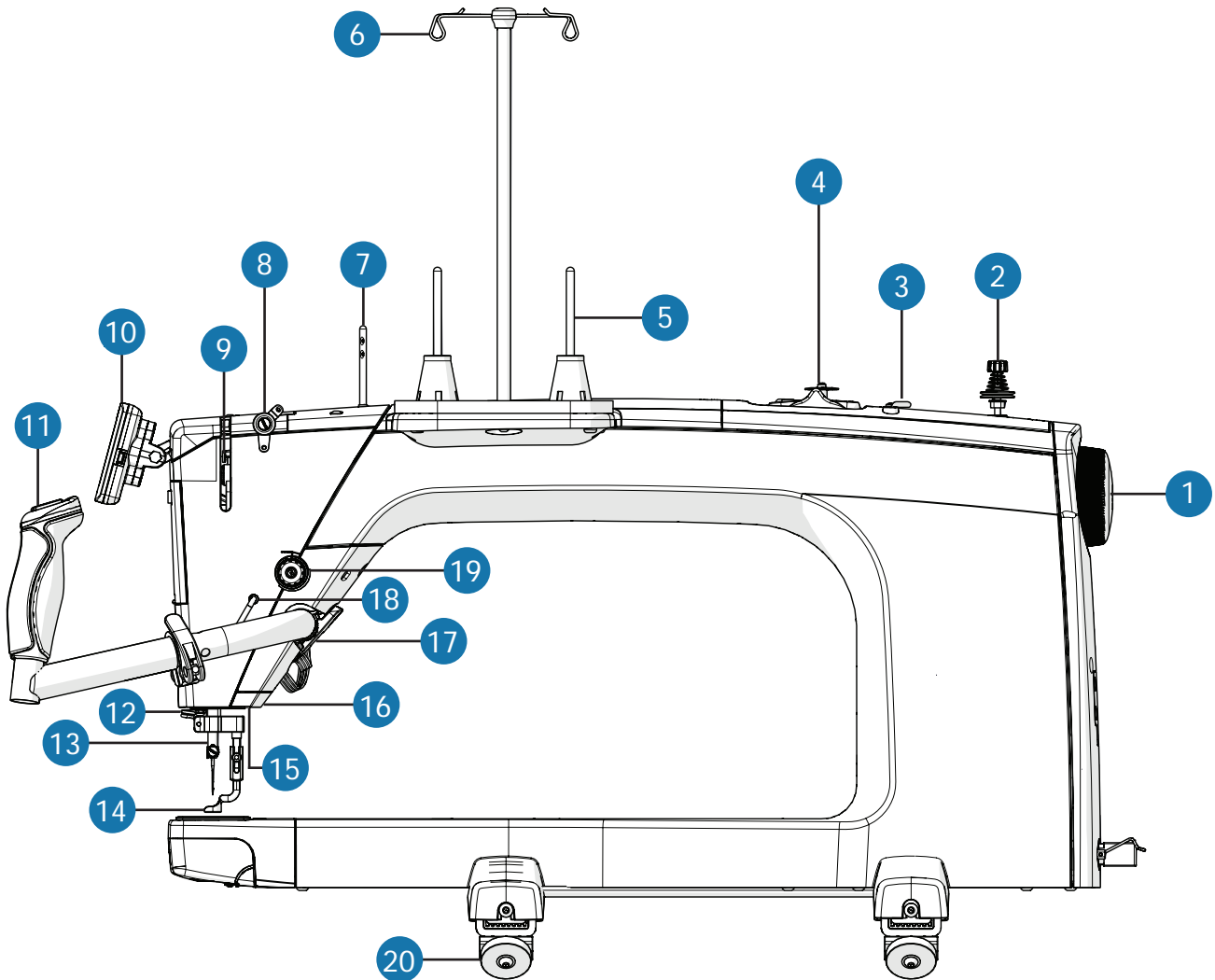

- 1 Hand Wheel**
Raises and lowers the needle bar.
- 2 Bobbin Thread Tensioner** (page 29)
Tensions thread for winding a bobbin.
- 3 Bobbin Thread Cutter** (page 29)
Cuts wound bobbin thread.
- 4 Bobbin Stand** (page 29)
Positions bobbin for winding.
- 5 Thread Stand** (page 29, page 34)
Holds a cone of thread.
- 6 Thread Mast** (page 29, page 34)
Guides the thread for quilting.
- 7 Thread Guide Rod** (page 34)
Positions thread when quilting.
- 8 Small Thread Tensioner** (page 34)
Tensions thread when quilting.
- 9 Take-Up Lever** (page 34)
Tensions thread when quilting.
- 10 Display** (page 22)
Provides access to quilting options.
- 11 Handlebar Controls** (page 44)
Controls machine functions.
- 12 Bottom Thread Guide** (page 34)
Positions thread when quilting.

- 13 Needle Bar** (page 73)
Holds the needle when quilting.
- 14 Hopping Foot** (page 96)
Presses fabric down when quilting.
- 15 Lamp**
Lights up needle area.
- 16 Thread Cutter** (page 34)
Cuts excess thread after threading machine.
- 17 Handlebar Clamp** (page 19)
Holds handlebars in place.
- 18 Thread Guide** (page 34)
Positions thread when quilting.
- 19 Large Thread Tensioner** (page 34)
Tensions thread as adjusted.
- 20 Machine Wheels** (page 5)
Rides the bottom carriage rails to move the machine up or down on the quilting frame.

Hook Assembly (Front View)

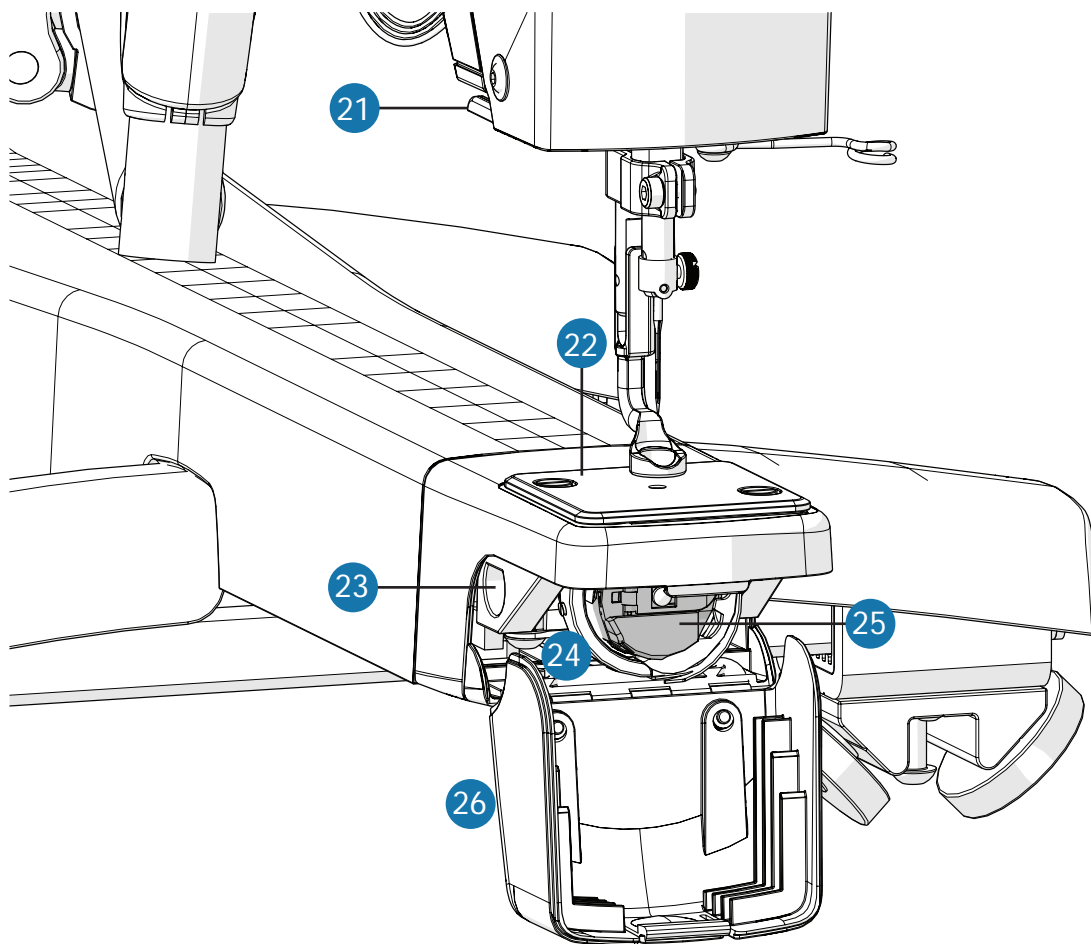

- 21 Thread Cutter** (page 34)
Cuts the thread after threading the machine.
- 22 Needle Plate** (page 80)
Covers top hook assembly access.
- 23 Timing Cut-Out** (page 91)
Accesses hook assembly set screws.
- 24 Hook Assembly** (page 32)
Holds the bobbin case and hooks the top thread to create stitches.
- 25 Bobbin Case** (page 32)
Holds M class bobbin and controls bottom thread tension.
- 26 Bobbin Cover** (page 32)
Covers the hook assembly and bobbin case.

Ports and Plugins

Machine Rear (Underside View)

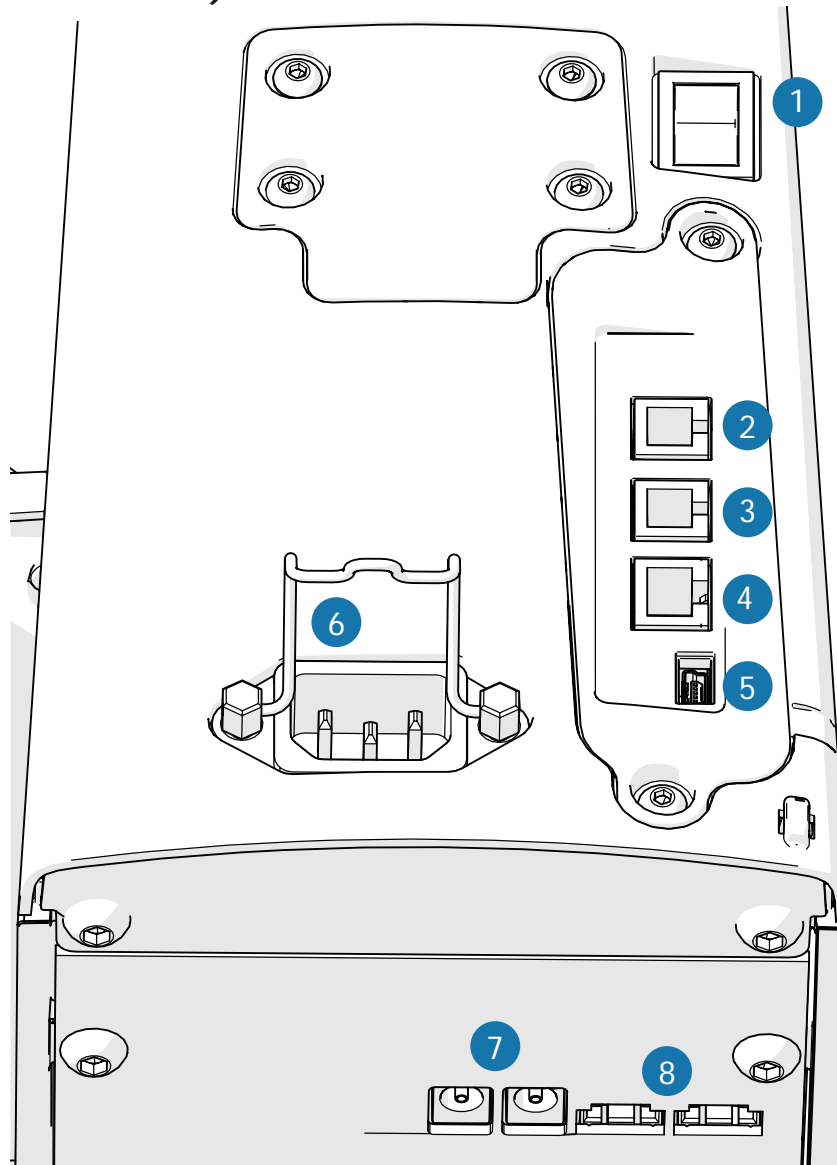

- 1 Power On/Off Switch** (page 27)
Turns machine on and off.
- 2 Lower Encoder Port** (page 5)
Connects encoders to machine.
- 3 Upper Encoder Port** (page 25)
Connects encoders to machine.
- 4 Quilt Motion Tablet Port**
For optional automation accessory.
- 5 USB Connector Port**
For updating only.
- 6 Power Port with Retainer** (page 27)
Connects and holds power cable to the machine.
- 7 Accessory Ports**
For laser accessory.
- 8 Back Handle Ports**
For back handle accessory.

Machine Front

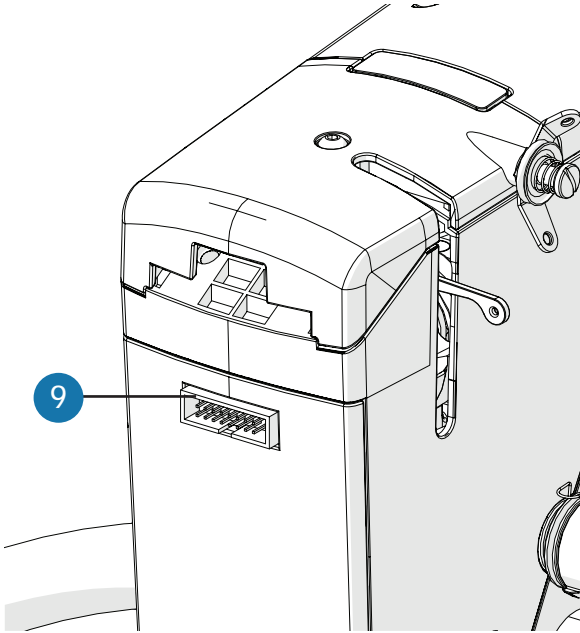

- 9 Display Cable Port** (page 22)
Connects display cable to machine.

Machine Throat

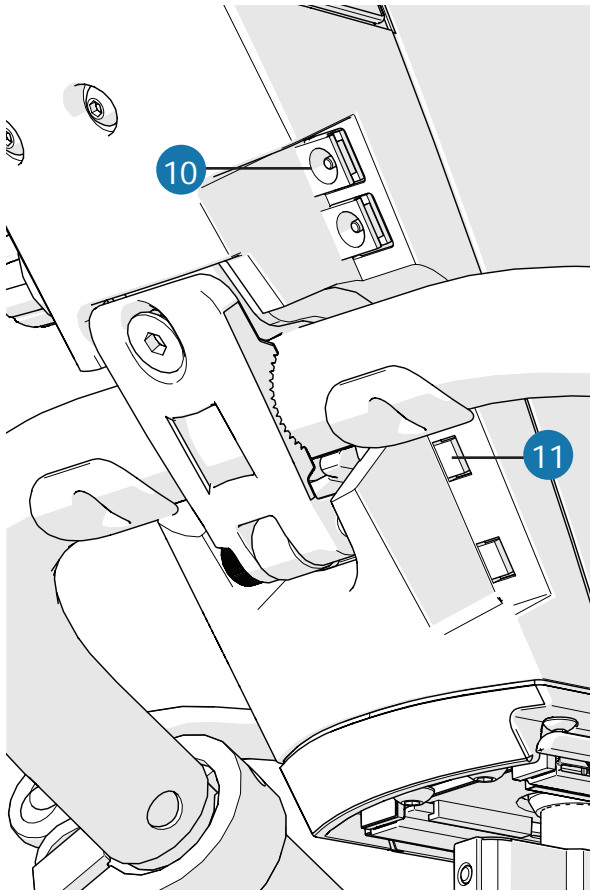

- 10 Accessory Ports**
For laser accessory.
- 11 Handlebar Ports** (page 19)
Connects handlebar controls to machine.

My Machine Details

Use this page to write down some information about your machine. This will be helpful if you ever need to call a Grace Company support technician.

Machine Type: Q'nique 19X

Machine Serial Number: _____

Date of Purchase: _____

What Frame are You Using? _____

Select Which Machine Accessories You Have Purchased:

- | | |
|--|---|
| <input type="checkbox"/> QuiltMotion | <input type="checkbox"/> Quilt Perfect Ruler Feet Kit |
| <input type="checkbox"/> Back Handles | <input type="checkbox"/> 360 Wonder Foot |
| <input type="checkbox"/> Q'nique Laser Stylus | <input type="checkbox"/> 4 Piece Accessory Hopping Foot |
| <input type="checkbox"/> Magnifique Magnifying Glass | <input type="checkbox"/> 9 Piece Accessory Hopping Foot |
| <input type="checkbox"/> Ruler Base | <input type="checkbox"/> Thread Spool Accessory |

Find your serial number on the silver sticker on the back of the machine.

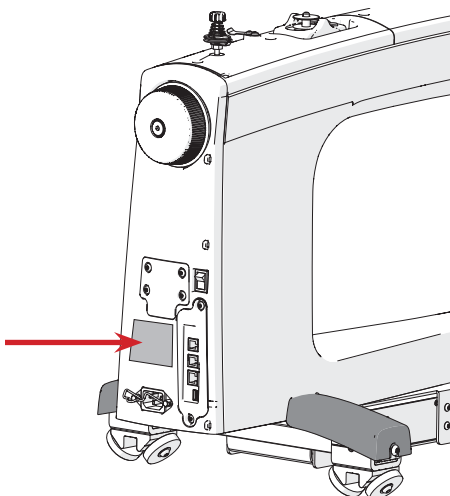

You may also be asked about your machine's firmware version. You can find this on the display after the machine is assembled and turned on. See page 62 for details.

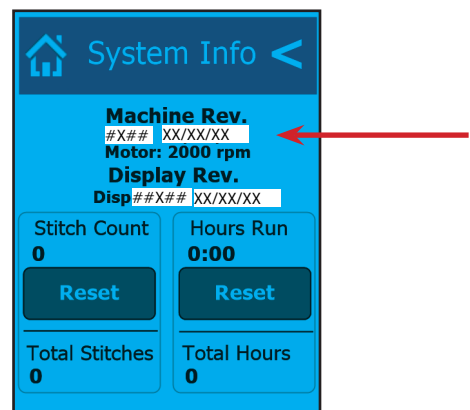

Included Parts and Tools

Level One (Workstation)

Tip: Parts are grouped together in the packaging for your convenience. For the best experience, do not remove parts from the packaging until instructed to do so.

Back Wheel Base Assembly

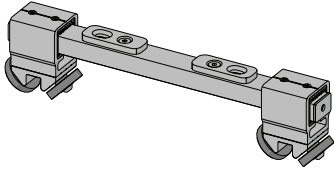

SMP-09-14385
See page 11

Front Wheel Base Assembly

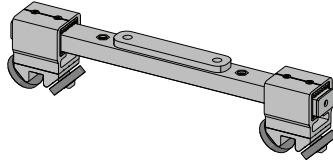

SMP-09-14386
See page 11

Tools Box

T-handle Allen Wrench 4 mm

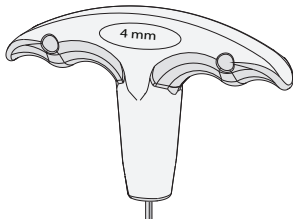

HDW-03-13114

T-handle Allen Wrench 3 mm

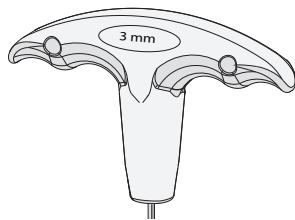

HDW-03-13115

T-handle Allen Wrench 2.5 mm

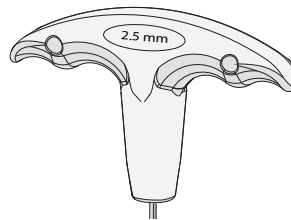

HDW-03-13116

T-handle Allen Wrench 2 mm

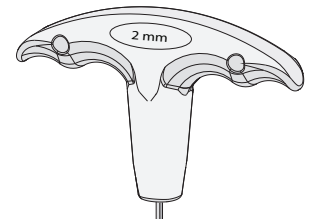

HDW-03-13117

Lint Brush

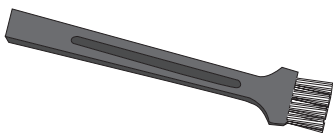

SMP-03-10170
See page 69

Needle Size 18
(one 10 pack)
(one pre-installed)

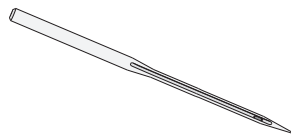

ACC-01-14517
See page 73

Needle Size 16
(one ten pack)

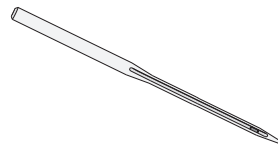

ACC-01-14516
See page 73

Needle Magnet

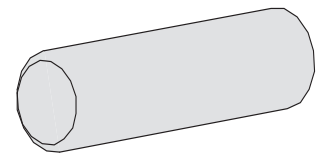

SMP-09-13837
See page 73

Included Parts and Tools (Continued)

Flat-head Screwdriver

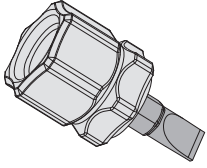

SMP-03-10169
See page 80

Hopping Foot Height tool

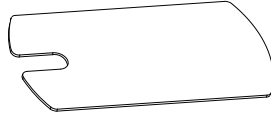

SMP-03-12171
See page 96

M Class Bobbin (x3) (Two pre-installed)

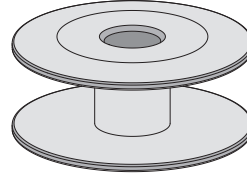

SMP-08-10070
See page 29

Timing Spacer Tool

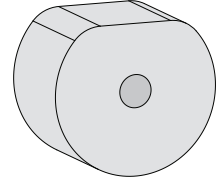

SMP-03-11320
See page 91

Encoder Box

Upper Encoder (silver spring)

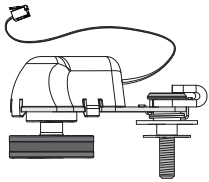

SMP-09-15701
See page 25

Lower Encoder (black spring)

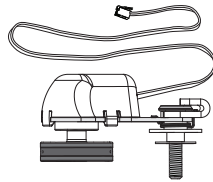

SMP-09-15700
See page 5

Zip Tie (x2) Zip Tie Mount (x2)

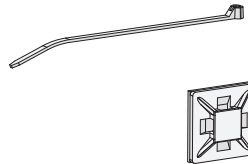

MIS-08-10805

Lower Encoder Spring (black)

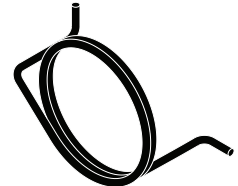

HDW-03-10671
See page 72

Upper Encoder Spring (silver)

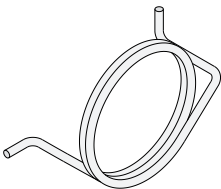

HDW-03-10216
See page 72

Wheel Base Hardware Box

SBHCS Screw M6 x 25 mm (x2)

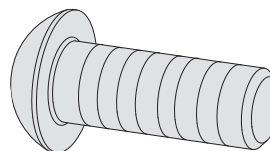

HDW-03-10215
See page 11

Shoulder Bolt M6 (x2)

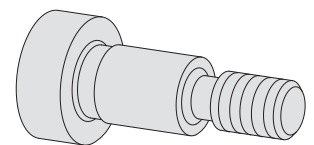

HDW-03-12206
See page 11

Wheel Base Cover Box

Back Right Wheel
Base Cover

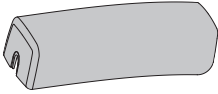

SMP-05-12164
See page 17

Back Left Wheel
Base Cover

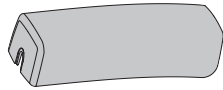

SMP-05-12165
See page 17

Front Left Wheel
Base Cover

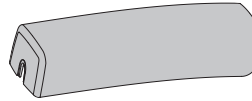

SMP-05-12166
See page 17

Front Right Wheel
Base Cover

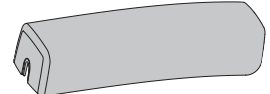

SMP-05-12167
See page 17

**SBHCS Screw
M6 x 14 mm (x4)**

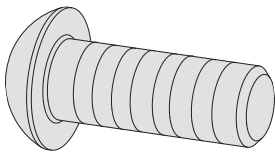

HDW-03-10974
See page 17

Display Box

**2.4 Inch Touch
Display**

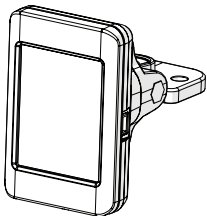

SMP-09-15716
See page 22

**SBHCS Screw
M5 x 16 mm (x2)**

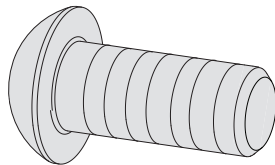

HDW-03-10857
See page 22

Included Parts and Tools (Continued)

Thread Stand Hardware Box

SBHCS Screw
M4 x 8 mm (x2)

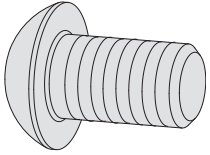

HDW-03-10012
See page 24

Power Cord/Oil Bottle Box

**Oil
Bottle**

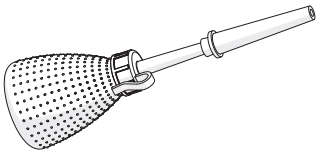

SMP-09-13888
See page 69

**Power
Cord**

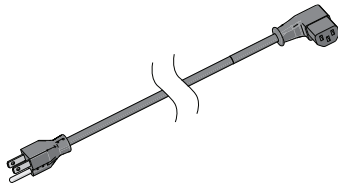

SMP-02-14466
See page 27

M3 Thumb Screw
(needle bar spare)

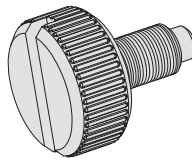

HDW-03-11736
See page 73

**Hopping Foot
Screw**

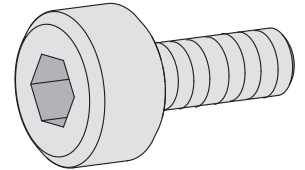

HDW-03-10966
See page 96

Level Two

Handlebar Assembly

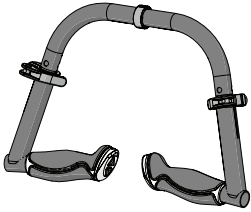

SMP-09-14066
See page 19

Thread Stand Assembly

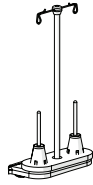

SMP-09-13183
See page 24

Sample Thread Kit

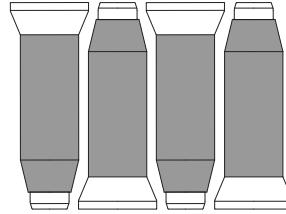

MIS-11-16122

Welcome to Your Q'nique 19X

We are pleased to introduce you to the newest part of your quilting setup. This machine has been especially designed to help quilters like you have the tools available to create quality projects.

This manual is broken into four sections (or parts). Notifications at the end of each section will direct you to switch to your frame manual or QuiltMotion manual for instructions on assembling those products. This creates a streamlined process of building a complete quilting setup in the most efficient way. Use the following flowchart to guide you in navigating multiple manuals. If you are not using one of the products in the flowchart, just move to the next item in the chart.

Thank you again for choosing us to help with your quilting projects.

- The Grace Company

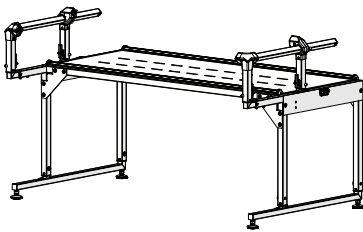

Start Here: Frame Manual: Part One

- Assemble the frame's legs, table, and sides.
- Install the channel lock onto the bottom carriage.
- Align your tracks.

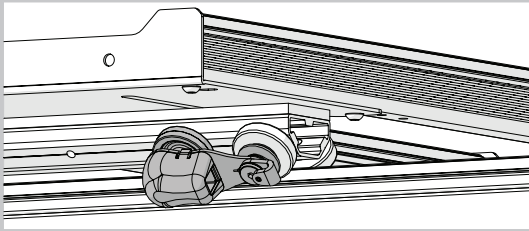

Quilting Machine Manual: Part One

- Install the lower encoder onto the bottom carriage.

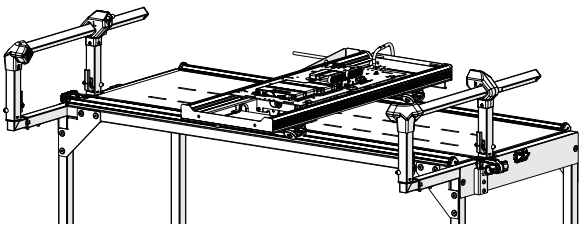

QuiltMotion Manual: Part One

- Prepare the bottom carriage.
- Install the long belt across the frame.

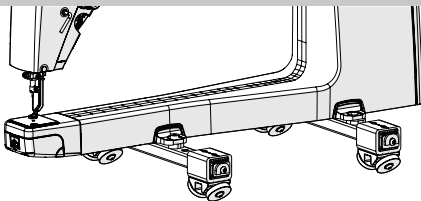

Quilting Machine Manual: Part Two

- Install your machine's wheels.
- Align your wheels.

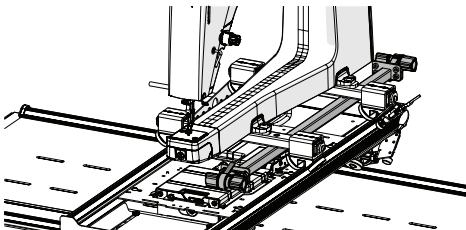

QuiltMotion Manual: Part Two

- Install the short belt.
- Tension the short belt.

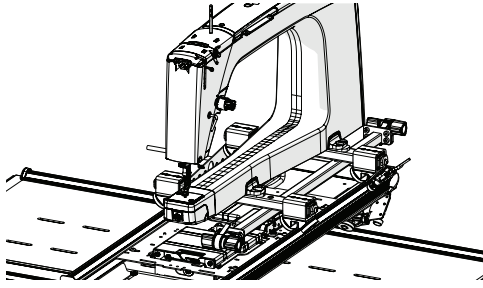

Frame Manual: Part Two

- Install the channel lock on the machine or top plate.
- Prepare the top plate and home sewing machine.
- Place the machine or top plate on the frame.

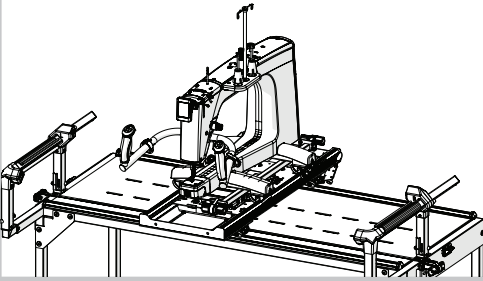

Quilting Machine Manual: Part Three

- Install the wheel covers, display, handles, thread mast.
- Install the upper encoder.

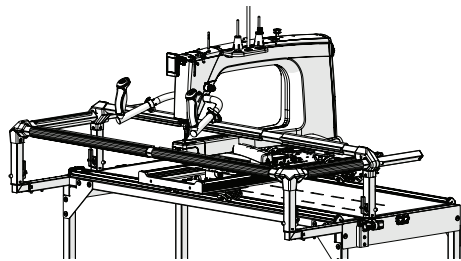

Frame Manual: Part Three

- Install the rails and fabric bungees.
- Position and adjust the rails.
- Adjust the carriage stop.
- Level the frame.

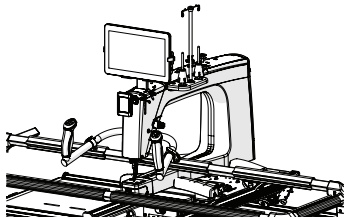

QuiltMotion Manual: Part Three

- Install the tablet bracket.
- Plug in QuiltMotion.

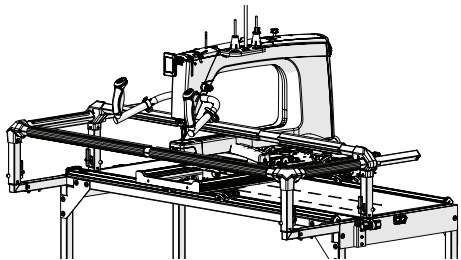

Frame Manual: Part Four

- Install the velcro tape
- Install the cloth leaders
- Attach the fabric

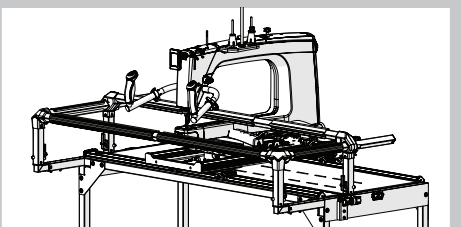

Quilting Machine Manual: Part Four

- Use the quilting modes and settings in the display.
- Maintain the machine and perform repairs.

Animated Instructions

To provide the best possible customer experience, we also offer animated video instructions for setting up this product. To view the animated instructions, visit our website at:

<https://www.graceframe.com/en/promotion/qnique-19x-resources>.

You can also use your smartphone to scan this QR code:



Out-of-the Box Assembly

This section of the manual covers all the steps to assemble the machine after you bring it home for the first time.

Task 1- Installing the Lower Encoder	page 5
Task 2 - Installing the Wheels	page 11
Task 3 - Installing the Wheel Base Covers	page 17
Task 4 - Installing the Handlebars	page 19
Task 5 - Connecting the Display	page 22
Task 6 - Attaching the Thread Stand	page 24
Task 7 - Installing the Upper Encoder	page 25
Task 8 - Turning the Machine On/Off	page 27

Part One

Before completing the tasks in Part One of your machine instructions, please complete Part One of your frame instructions.

Progress Checkpoint:

Have you:

- Assembled your frame's legs and table?
- Installed and align the frame tracks?
- Installed the channel lock on the bottom carriage?
- Installed the rail supports?

Note: Do not install the rails at this time.

If you've already fully assembled your frame, uninstall your frame's take-up rail.

Task 1- Installing the Lower Encoder

Parts & Tools Needed:

Lower Encoder
(black spring)

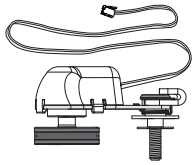

Encoder Box

T-handle Allen
Wrench 4 mm

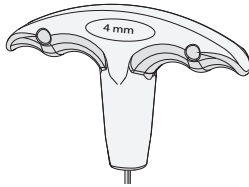

Tools Box

T-handle Allen
Wrench 2.5 mm

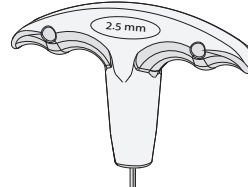

Tools Box

Instructions

The encoders monitor the position of the machine over the frame, allowing for regulated stitching. The lower encoder is installed on the left-rear wheel of your frame's bottom carriage. Please take the following steps to install the encoder onto the bottom carriage:

- 1 The parts and tools needed for this step are located in the **encoder and tools boxes**. The lower encoder has the black spring and green sticker.

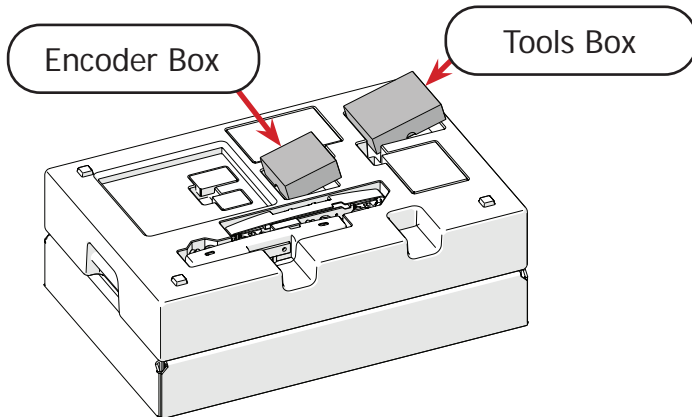

- 2 Loosen the **lock collar screw** on the lower encoder with the 2.5 mm Allen wrench until the **lock collar** (shown in blue) turns freely.

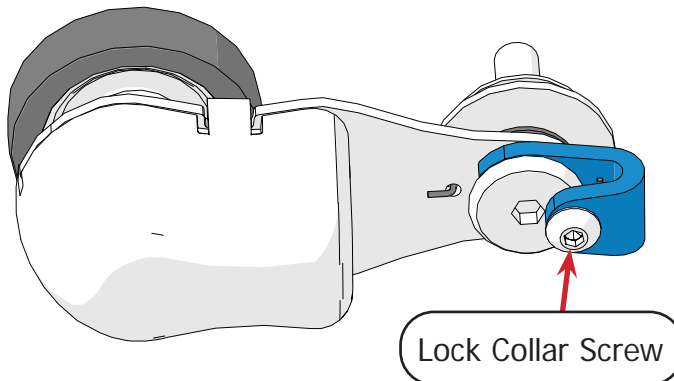

- 3 Locate the back left wheel of your bottom carriage. **Note:** If needed, review your frame assembly manual to determine the front of the bottom carriage.

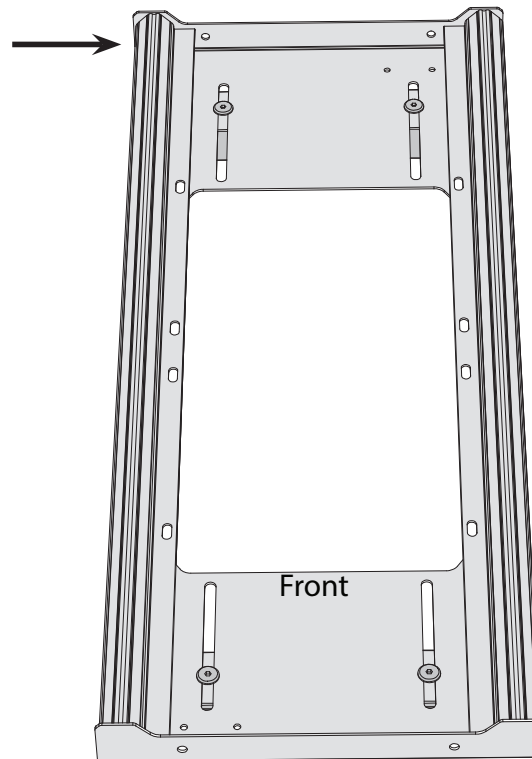

Note: Bottom carriage appearance will vary by model.

Task 1- Installing the Lower Encoder (Continued)

- 4 For the following steps, know whether your bottom carriage is dual-wheel (two wheels at each corner) or single-wheel (one wheel at each corner). If it is dual-wheel, does it have large wheels or small wheels?

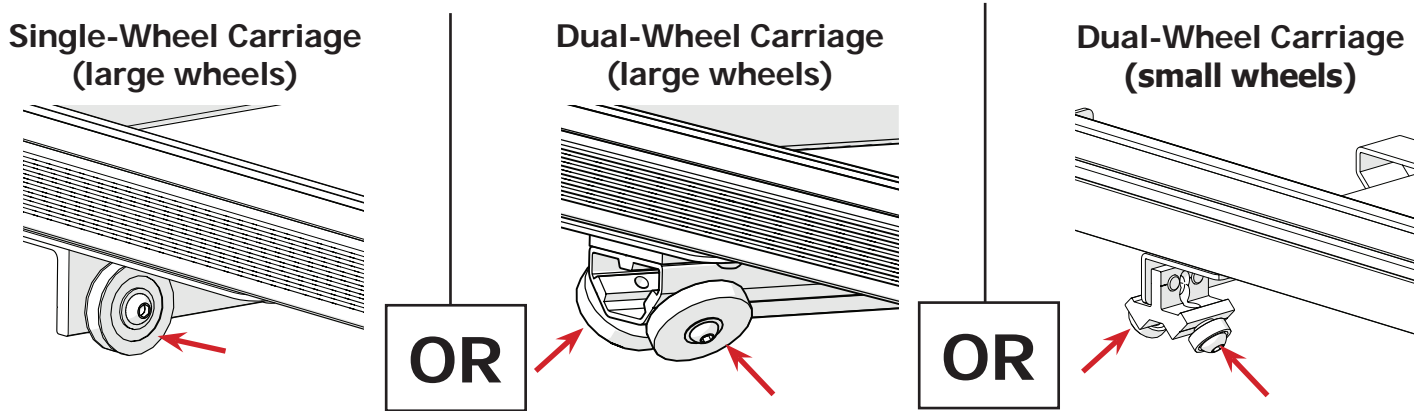

- 5 For large wheel carriages: Use the 4 mm Allen wrench to remove the left rear **wheel** from the bottom carriage and install it onto the encoder screw. The **wheel screw** will not be needed again and can be stored with the packaging materials.

For single-wheel carriages, place the spacer on the encoder after the wheel.

Single-Wheel Carriage

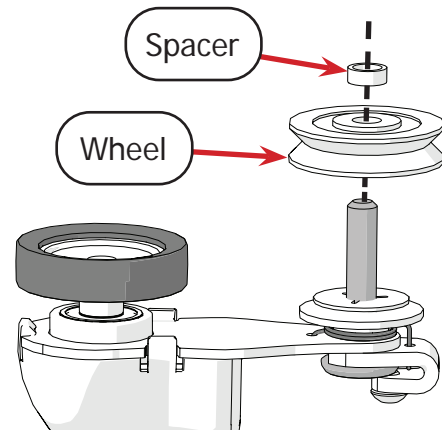
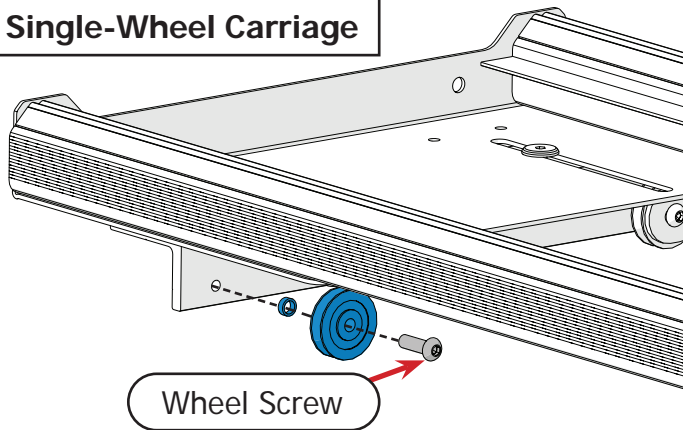

On dual-wheel carriages, remove the **outward-facing wheel** (shown in blue) and place the wheel onto the encoder screw so the **wheel hub** faces away from the encoder.

Large Dual-Wheel Carriage

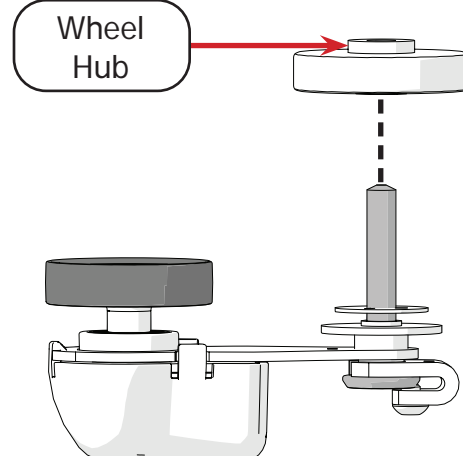
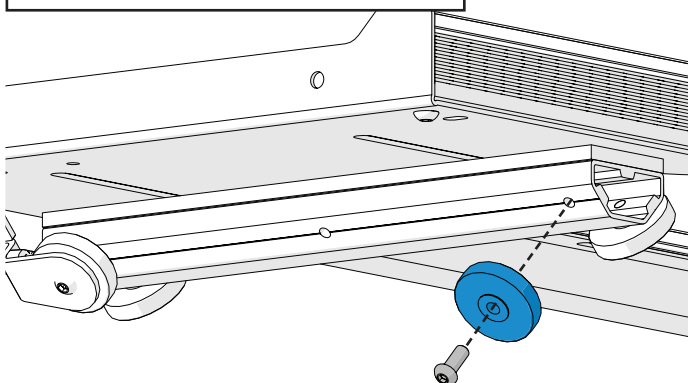

Task 1- Installing the Lower Encoder (Continued)

For the small, dual-wheel bottom carriage: Do not remove the wheels. Ensure the lower encoder bracket has been installed on the back of your bottom carriage. These steps are covered in your frame instruction manual.

Small Dual-Wheel Carriage

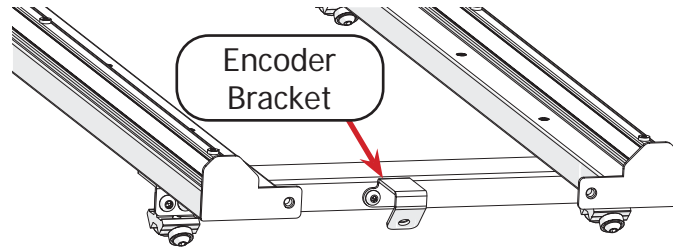

6 For the large wheel bottom carriages: With the 4 mm Allen wrench, screw the encoder into the left rear wheel hole on the carriage so the **encoder wheel** is between the rear wheels.

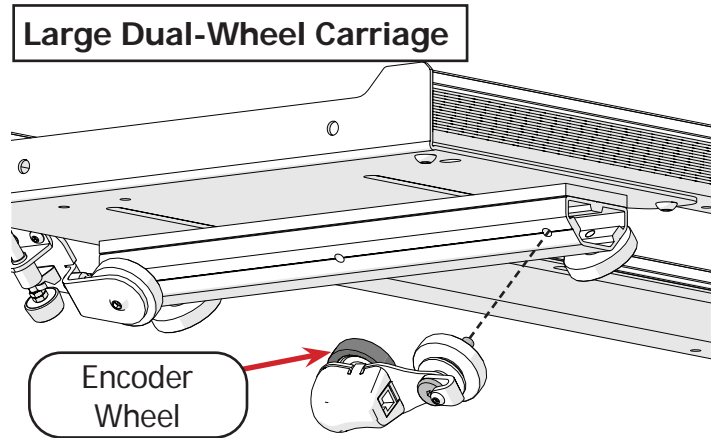
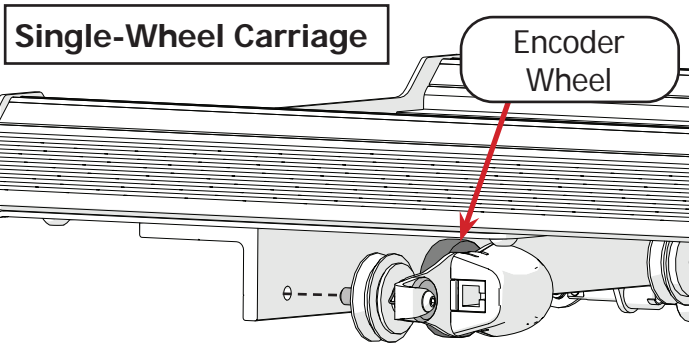

For the small, dual-wheel bottom carriage: Install the encoder directly onto the encoder bracket at the rear of the carriage so the **encoder wheel** is to the left of the bracket. Tighten with the 4 mm Allen wrench.

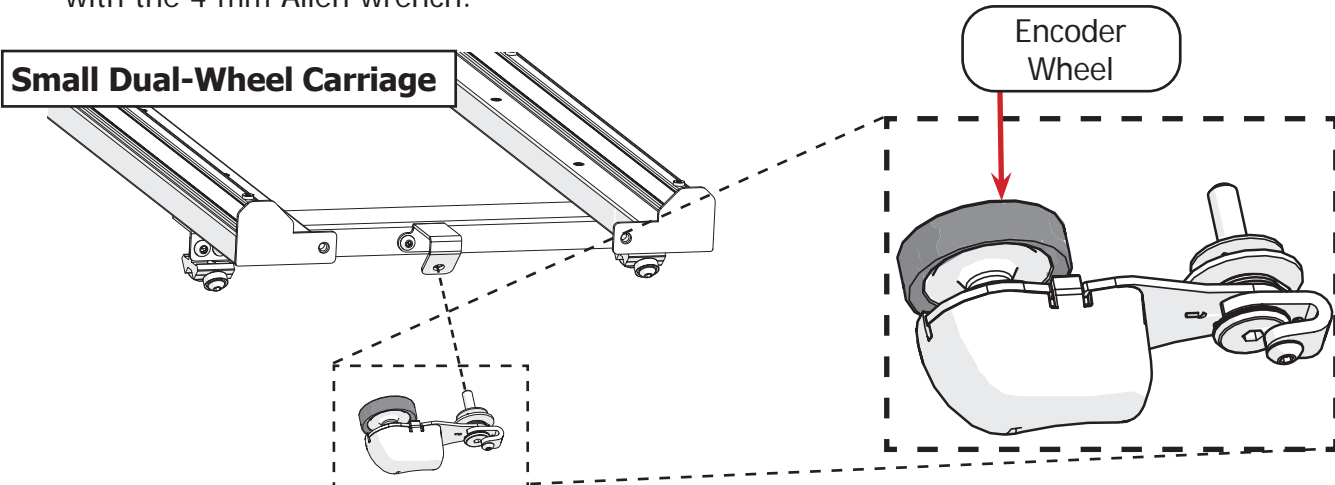

Task 1- Installing the Lower Encoder (Continued)

- 7 Turn the encoder **lock collar** (shown in blue) to point up. Then tighten the **lock collar screw** with the 2.5 mm Allen wrench.

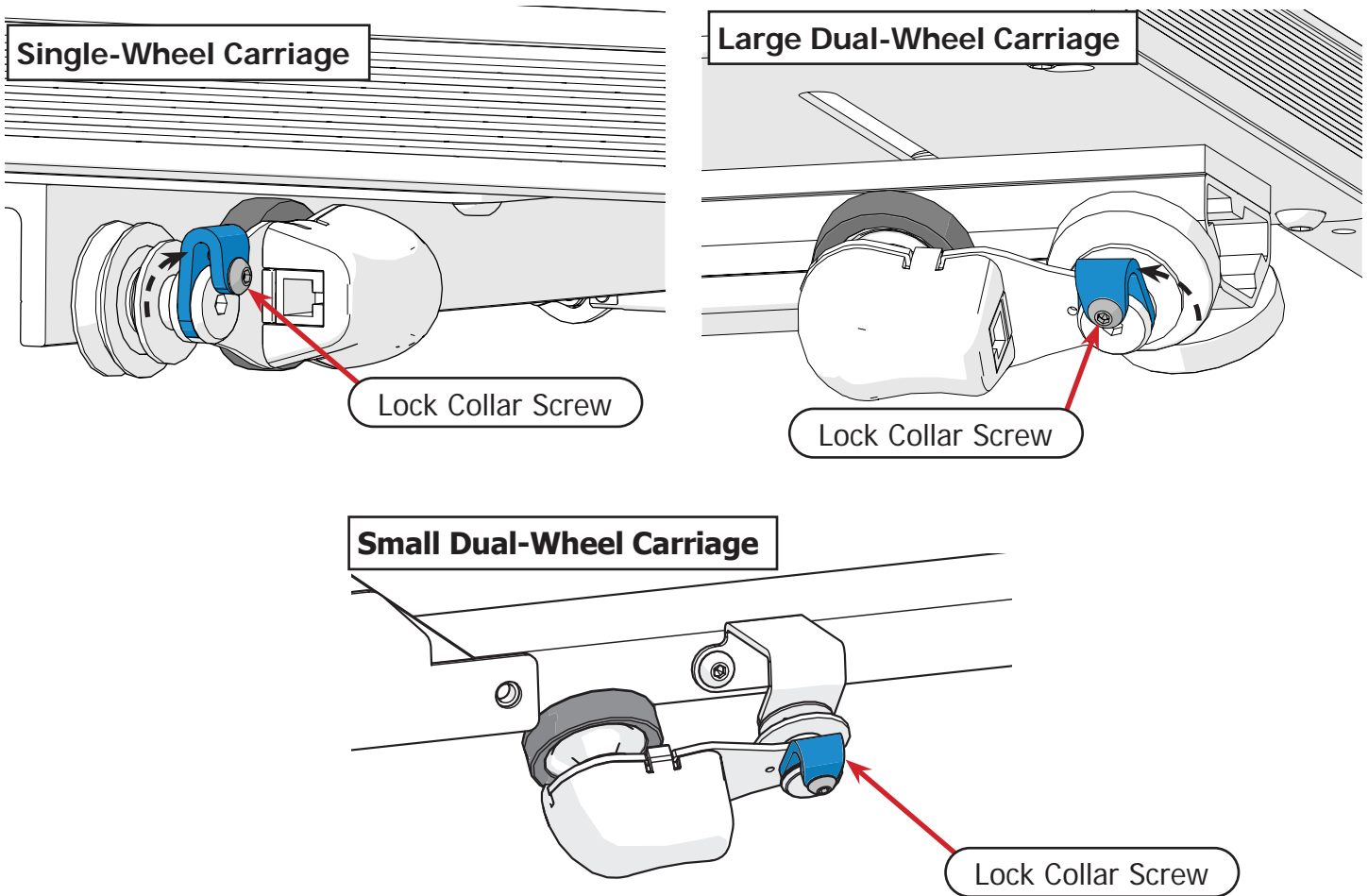

- 8 **For the large wheel bottom carriages:** Take the free end of **encoder cable** (shown in blue) and pull it through the slot in the bottom carriage behind the wheels.

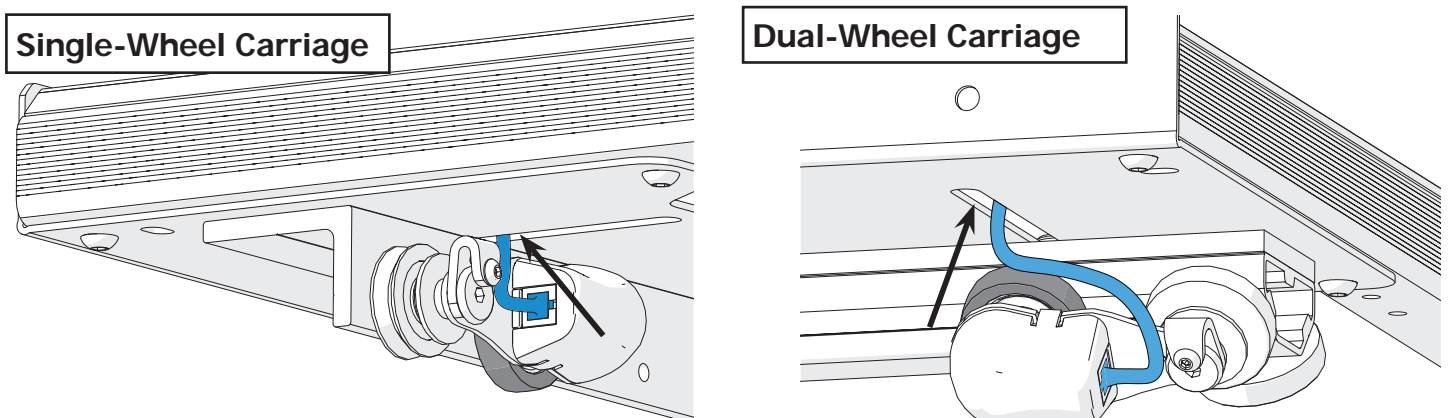

Note: For the small dual-wheel carriage this step is not needed.

Task 1- Installing the Lower Encoder (Continued)

Note: Instructions for plugging the cable into the machine are covered in “Choosing Your Needle” on page 96 after the machine has been installed.

Congratulations! You have completed Part One of this manual.

If you are also installing QuiltMotion, complete Part One of your QuiltMotion manual.

If you are not installing QuiltMotion at this time, continue to Part Two of this manual on page 10.

Part Two

Before completing the tasks in Part Two of your machine instructions, please complete Part One of your QuiltMotion instructions if you will be installing automation today.

Progress Checkpoint:

QuiltMotion Manual Part One (optional)

Have you:

- Installed the motor plate into your bottom carriage?
- Installed the long belt onto your frame?

Task 2 - Installing the Wheels

Parts & Tools Needed:

Back Wheel Base Assembly

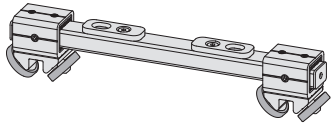

Front Wheel Base Assembly

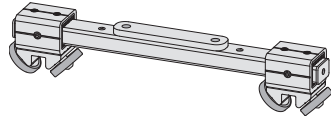

T-handle Allen Wrench 4 mm

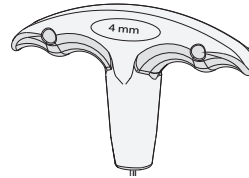

SBHCS Screw M6 x 25 mm (x2)

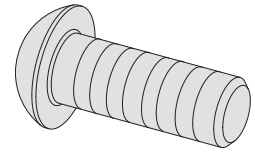

Packaging Level 1 (leave in packaging)

Packaging Level 1 (leave in packaging)

Wheel Base Hardware Box

Shoulder Bolt M6 (x2)

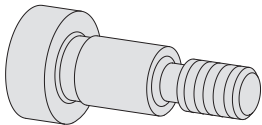

Wheel Base Hardware Box

Instructions

The machine wheels move the machine across the bottom carriage. To install the machine wheels:

- 1 Lift up the first level of packaging and place it beside the second level. Find the screws and bolts needed for this task in **box 3**.

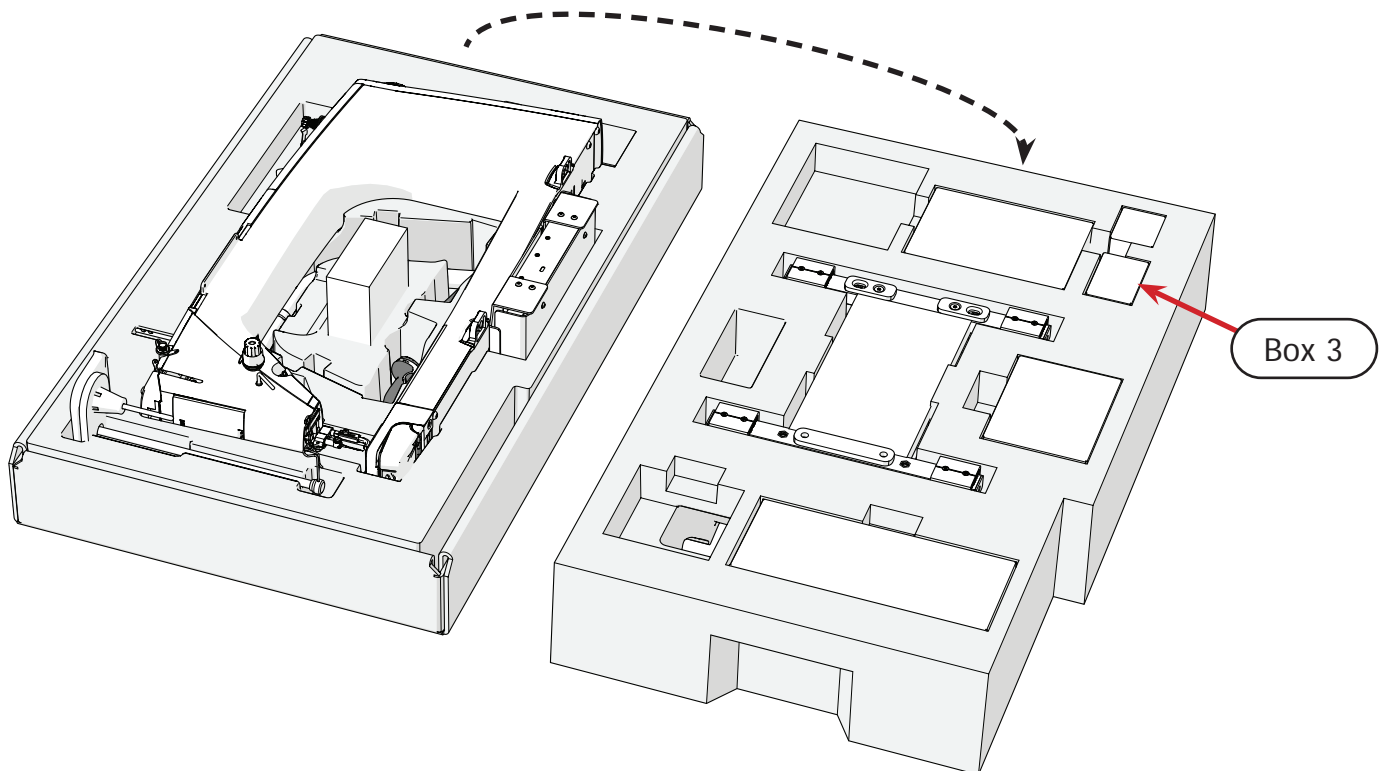

- 2 Remove the center **foam** from the first level of packaging.

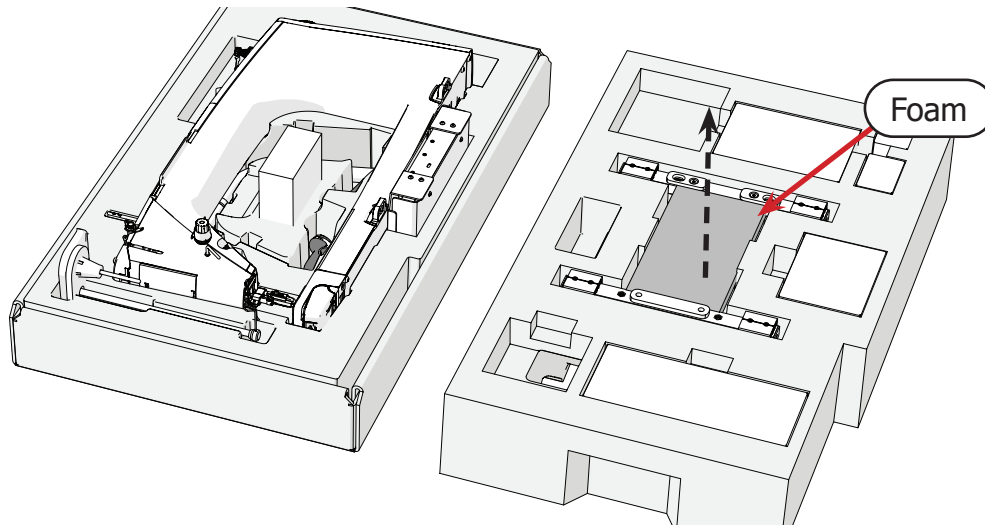

- 3 Take the machine body out of the second level of packaging and place it onto the **wheel base assemblies** in the first level.

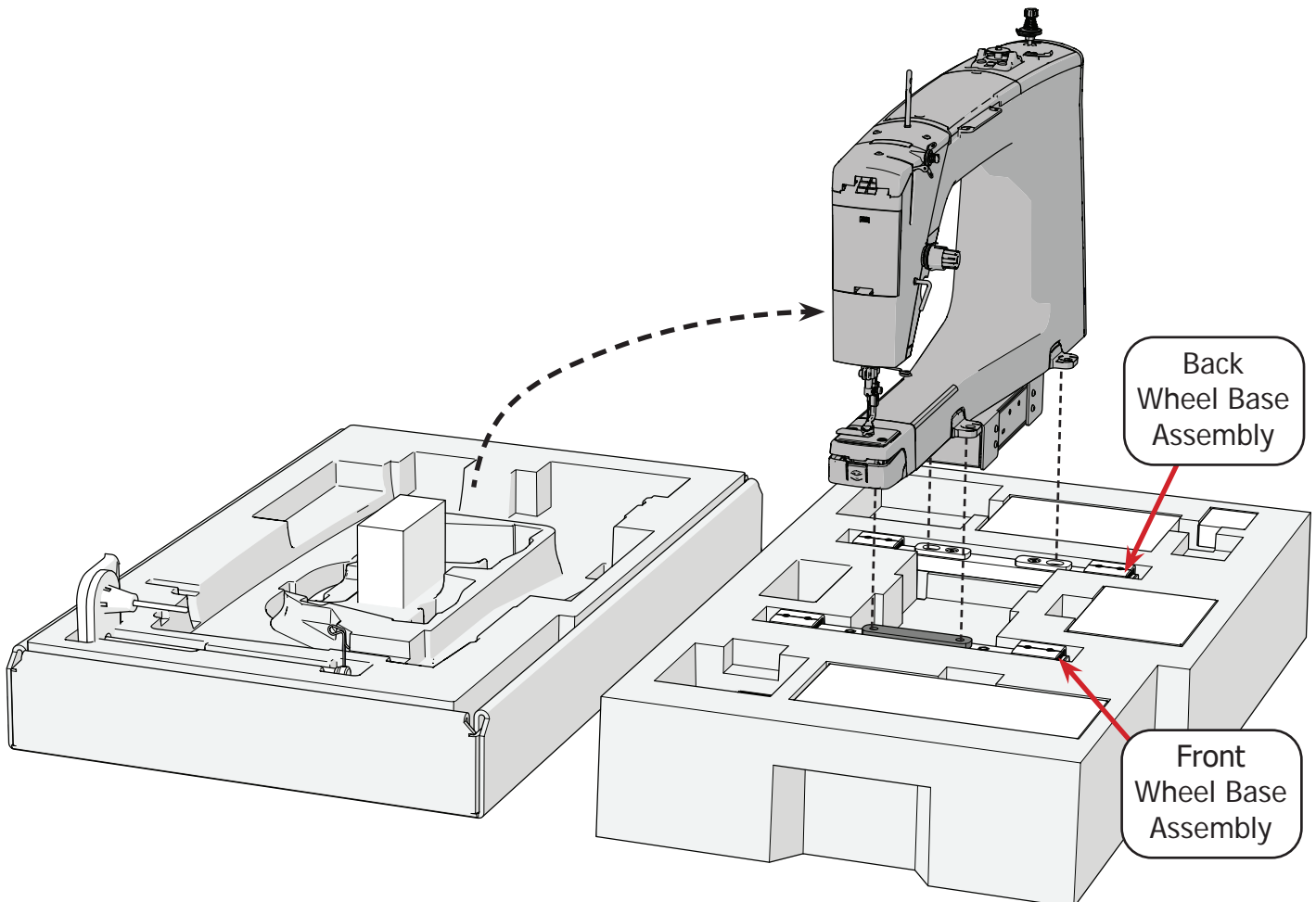

Part Two | Out of Box Assembly

Installing the Wheels (Continued)

- 4 Screw the back wheel base assembly in place with two **M6 x 25 mm screws SBHCS** and the 4 mm Allen wrench.

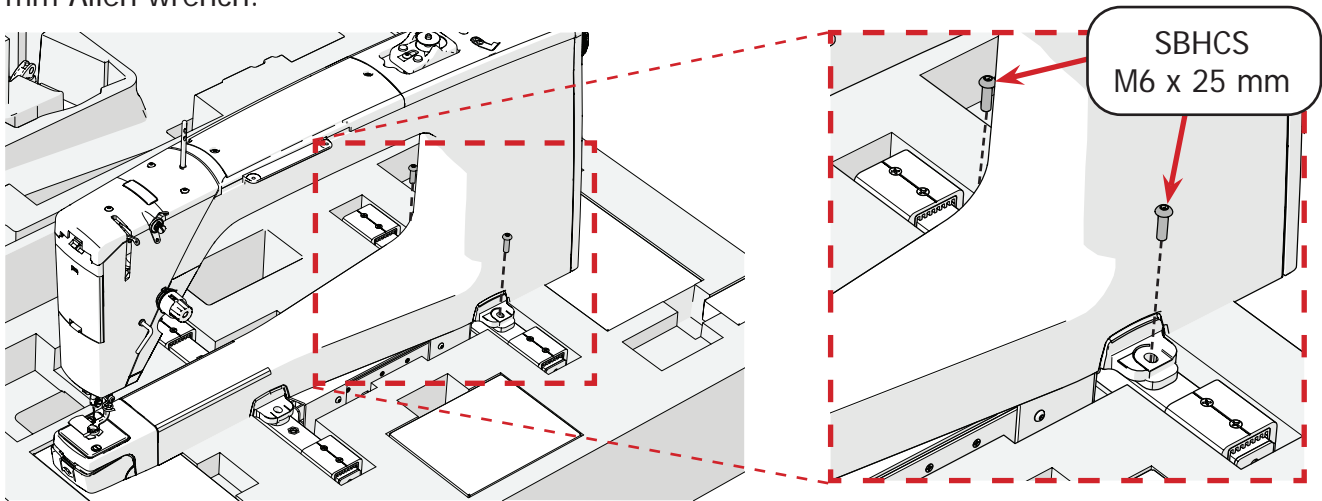

- 5 Use the 4 mm Allen wrench to screw in the **M6 shoulder bolts** into the front wheel base assembly.

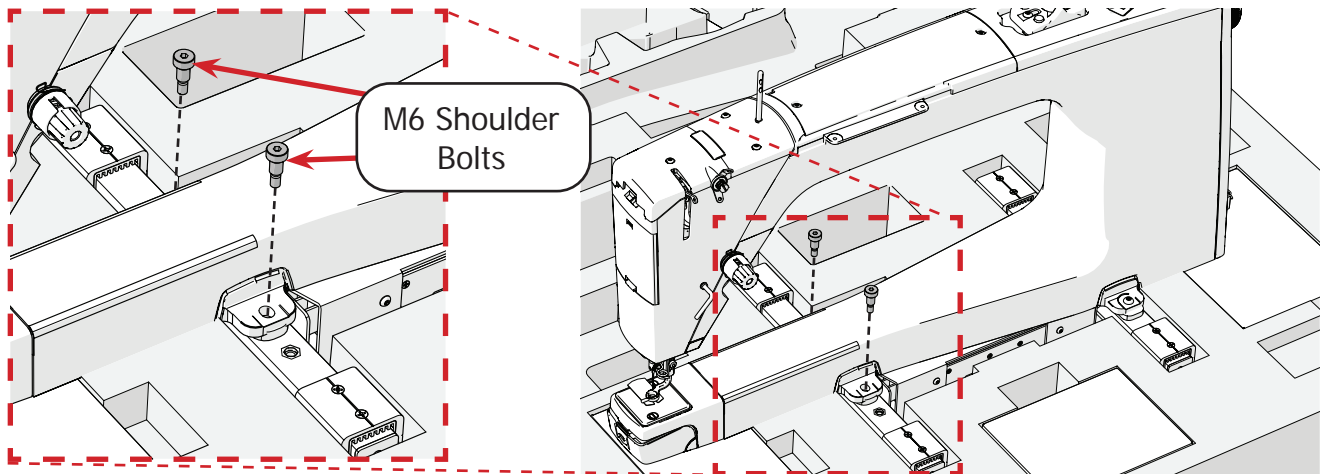

- 6 Now lift the machine out of the packaging. Place the machine onto your frame's bottom carriage, aligning the wheels with the tracks. See your frame's manual for bottom carriage orientation.

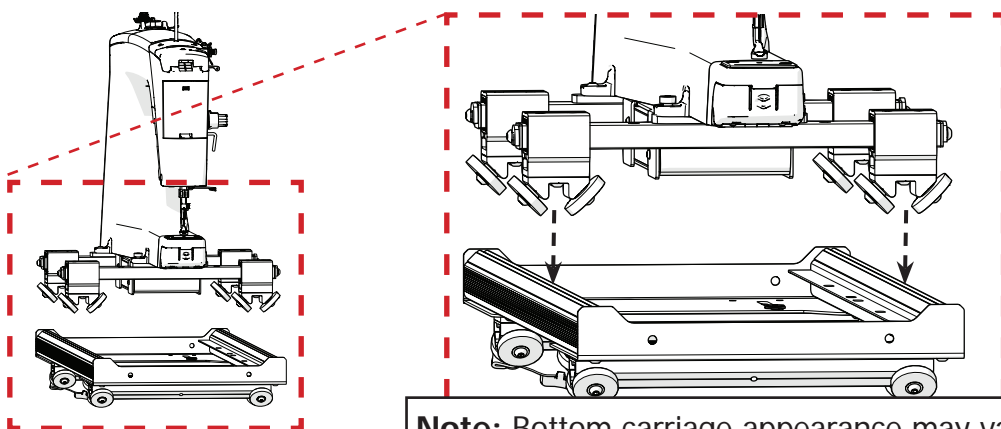

Note: Bottom carriage appearance may vary.

- 7 Loosen two set screws on one side of the machine (either the right side or left side) with the 4 mm Allen wrench.

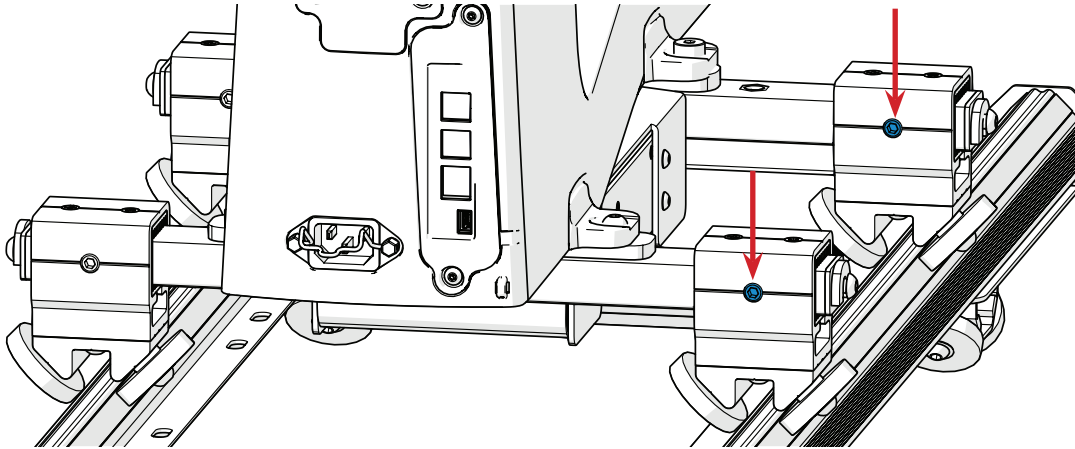

- 8 Slide the machine up and down the bottom carriage tracks.

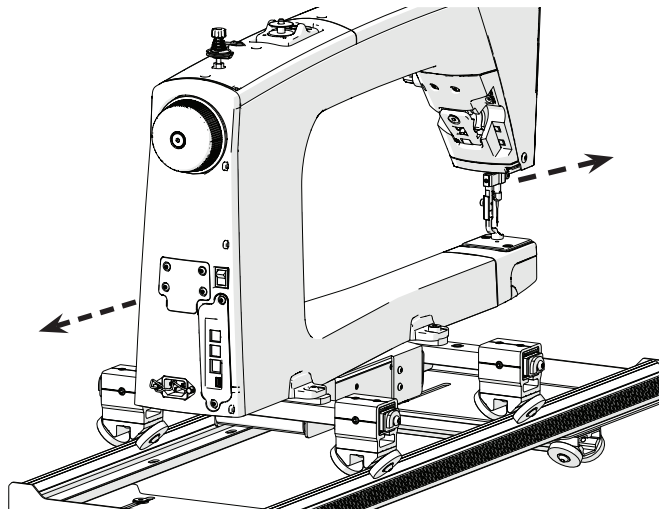

- 9 Check that the machine is centered over the wheels. If needed, shift the machine from side to side.

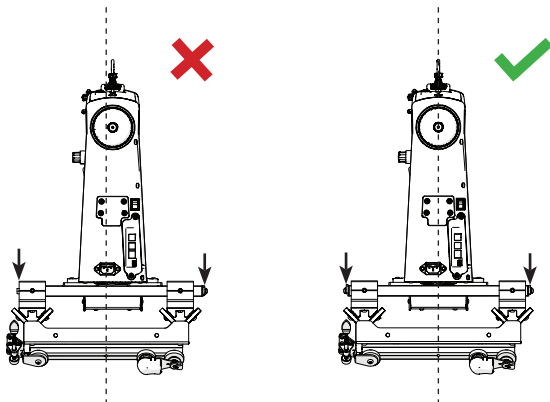

- 10 Re-tighten the wheel block set screws with the 4 mm Allen wrench.

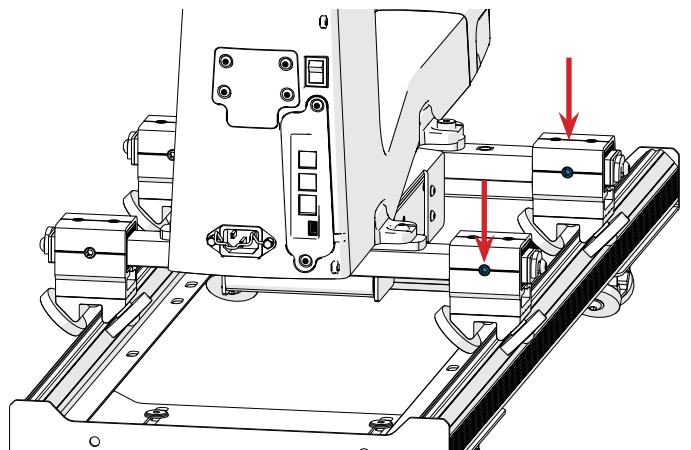

Congratulations! You have completed Part Two of this manual.

If you are also installing QuiltMotion, complete Part Two of your QuiltMotion manual.

If you are not installing QuiltMotion at this time but are assembling a new frame, continue to Part Two of your frame manual. If the frame manual is not broken in to parts, follow the manual's directions to:

- Install the channel lock onto your machine.

If you are installing your machine onto a frame that is already fully assembled, continue to Part Three of this manual on page 16.

Part Three

Before completing the tasks in Part Three of your machine instructions, please complete Part Two in your QuiltMotion manual (if setting up QuiltMotion at this time), and then part Two of your frame manual.

Progress Checkpoint:

Have you:

- Completed QuiltMotion Part Two (optional)

Have you:

- Installed the channel lock onto the quilting machine?

If you've already fully assembled your frame:

- Install the channel lock onto the quilting machine.

Task 3 - Installing the Wheel Base Covers

Parts & Tools Needed:

Front Left Wheel
Base Cover

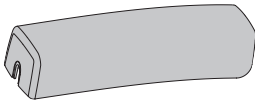

Wheel Base Cover Box

Front Right Wheel
Base Cover

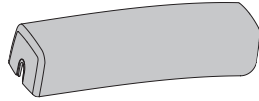

Wheel Base Cover Box

Back Left Wheel
Base Cover

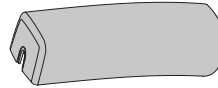

Wheel Base Cover Box

Back Right Wheel
Base Cover

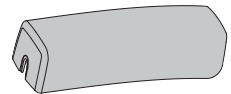

Wheel Base Cover Box

SBHCS Screw
M6 x 16 mm (x4)

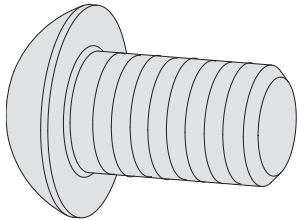

Wheel Base Cover Box

T-handle Allen
Wrench 4 mm

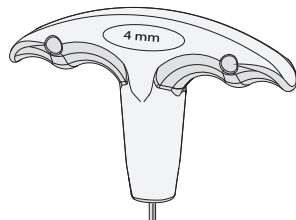

Instructions

Take the following steps to install the wheel base covers onto the machine:

- 1 The parts needed for this task are found in the **wheel base cover box**.

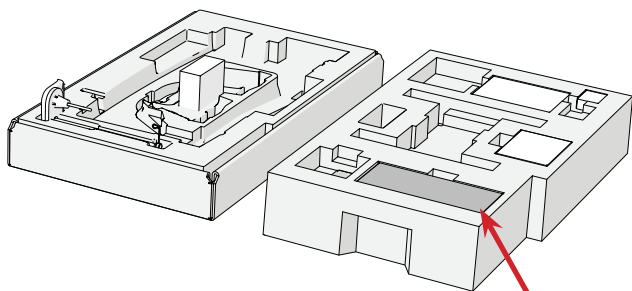

Wheel Base Cover
Box

- 2 Locate the label on the inside of each wheel cover.

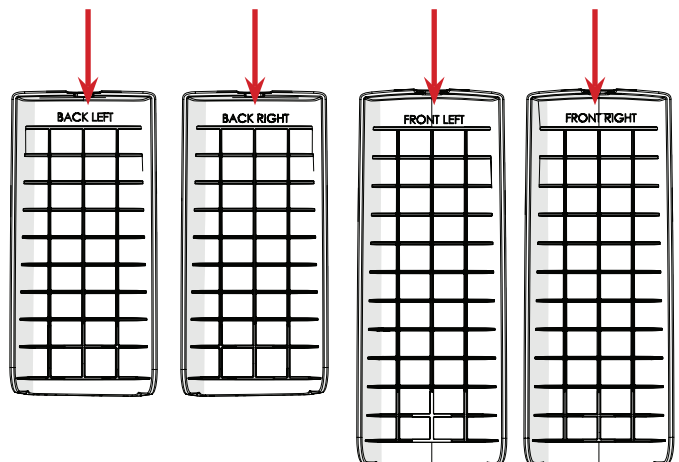

Installing the Wheel Base Covers (Continued)

- Slide the covers onto the associated leg.

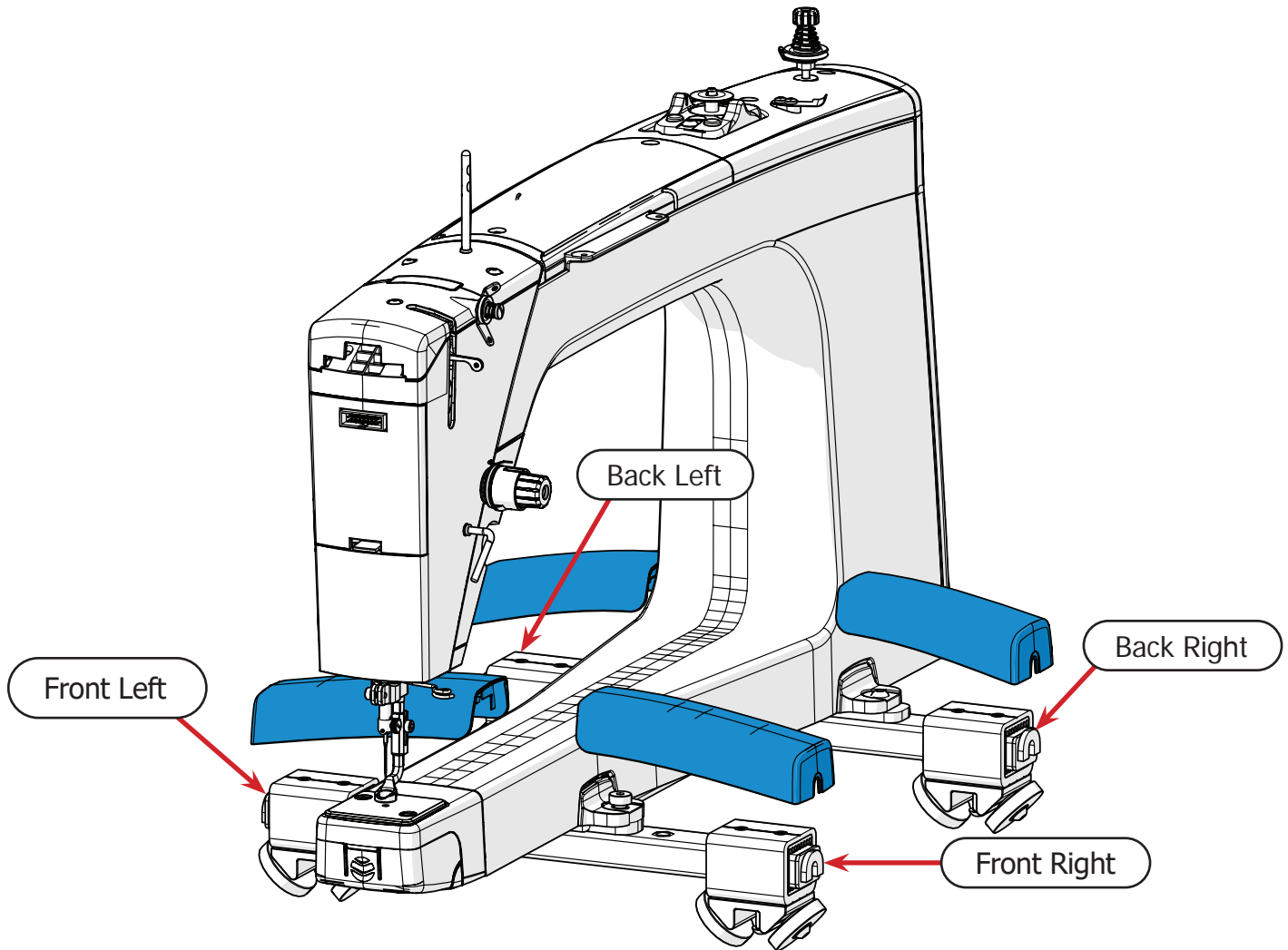

- Screw each cover into place using an **M6 x 16 mm SBHCS** and the 4 mm Allen wrench. Tighten until snug.

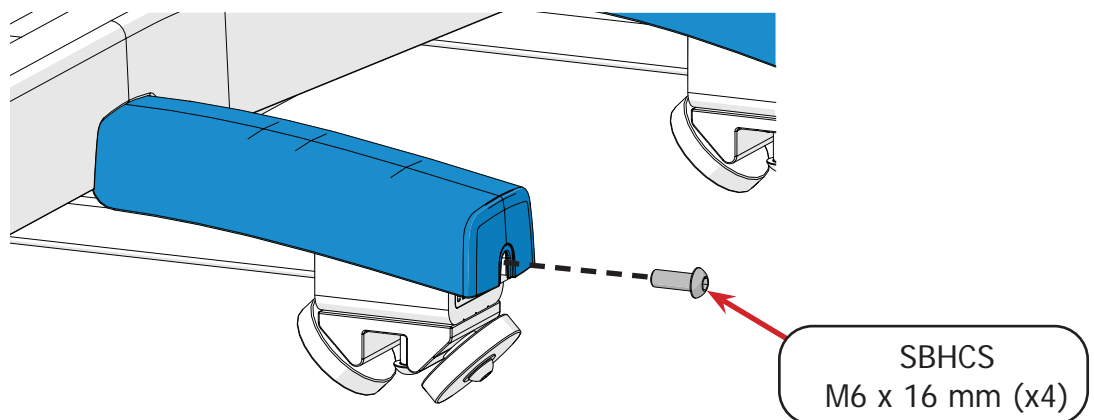

Task 4 - Installing the Handlebars

Parts & Tools Needed:

Handlebar Assembly

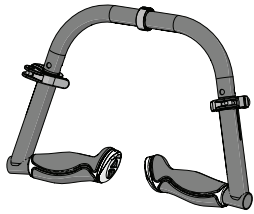

T-handle Allen Wrench 4 mm

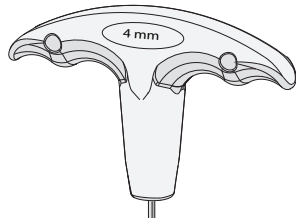

Packaging Level 2

Instructions

Take the following steps to install and adjust the handlebars:

- 1 With the 4 mm T-handle Allen wrench, remove the **handlebar clamp screw** to open the handlebar clamp.

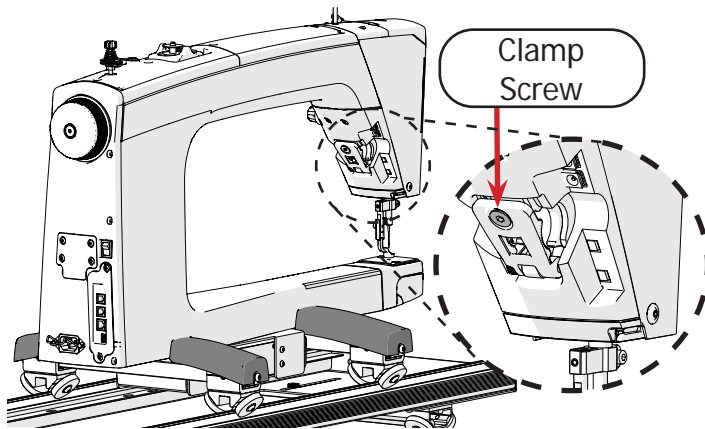

The handlebar clamp opens.

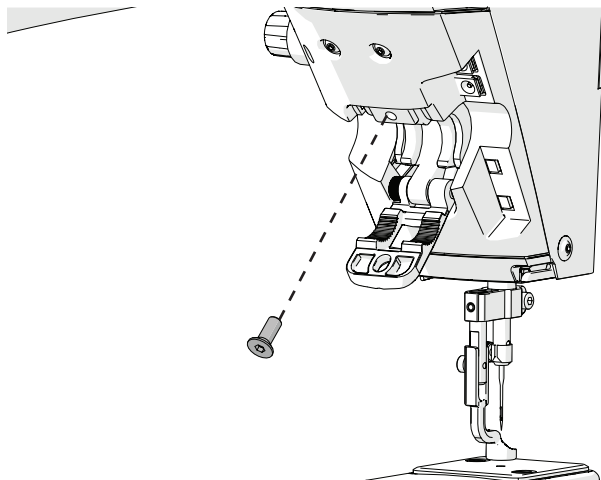

- 2 Take the **handlebar assembly** from the second level of the packaging.

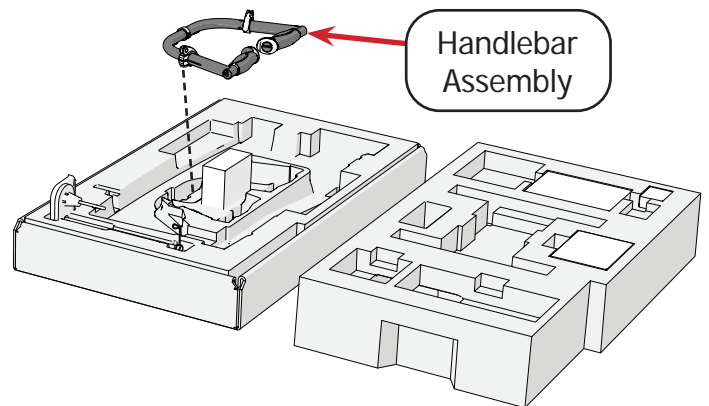

- 3 Slide them into the slot so that the **cables** are on the bottom.

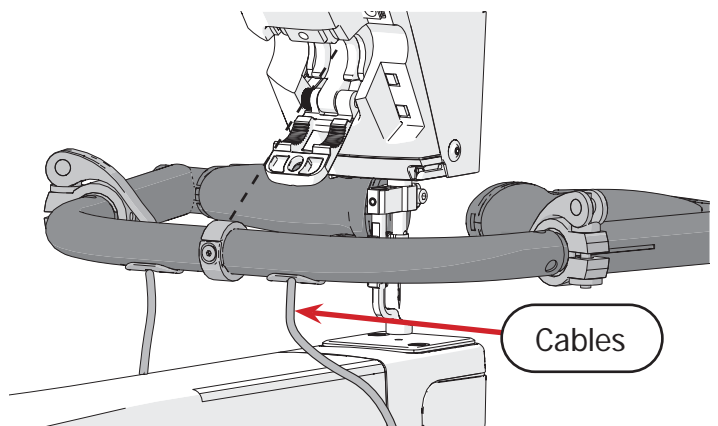

Task 4 - Installing the Handlebars (Continued)

- 4 Close and hold the clamp, and loosely screw in the **clamp screw**.

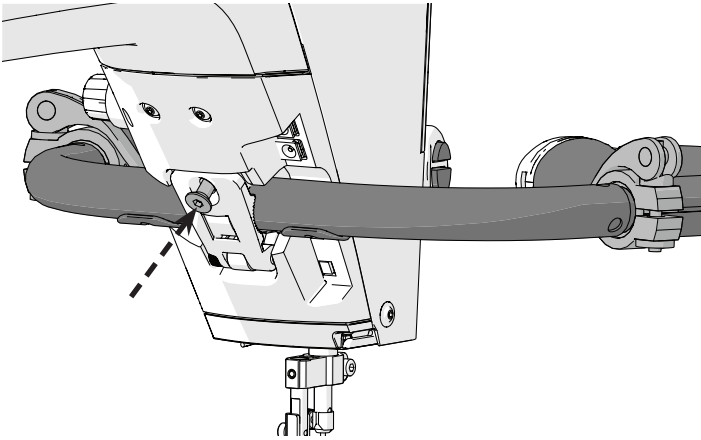

- 5 Hold the handlebars at the desired angle and tighten the **clamp screw**.

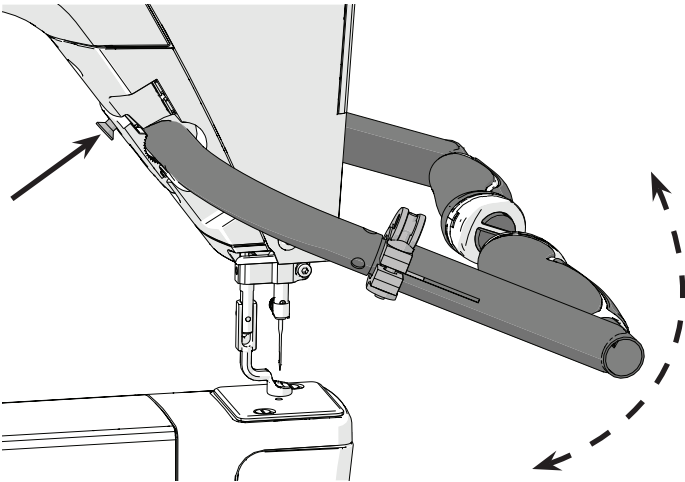

- 6 Open the **handlebar levers** (shown in blue).

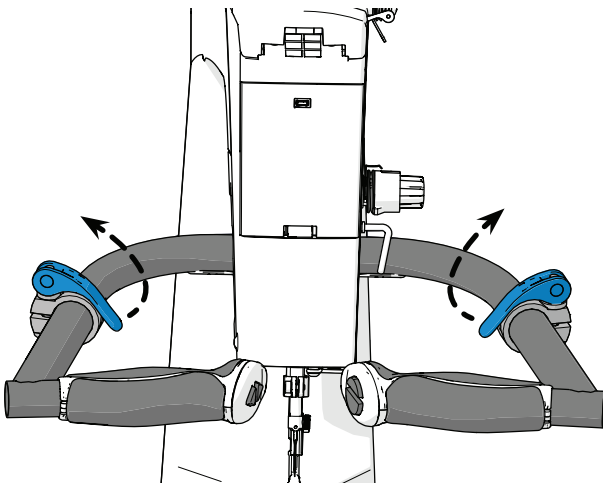

- 7 Twist the controls vertically until they are comfortable to hold and operate.

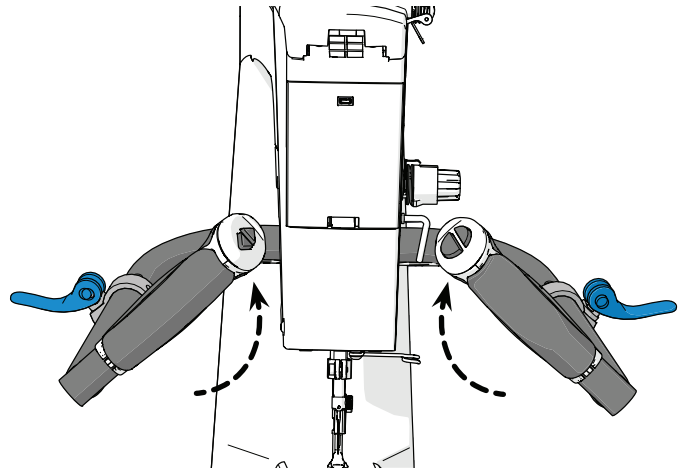

- 8 If desired, extend the handles outward to improve the reach of the machine.

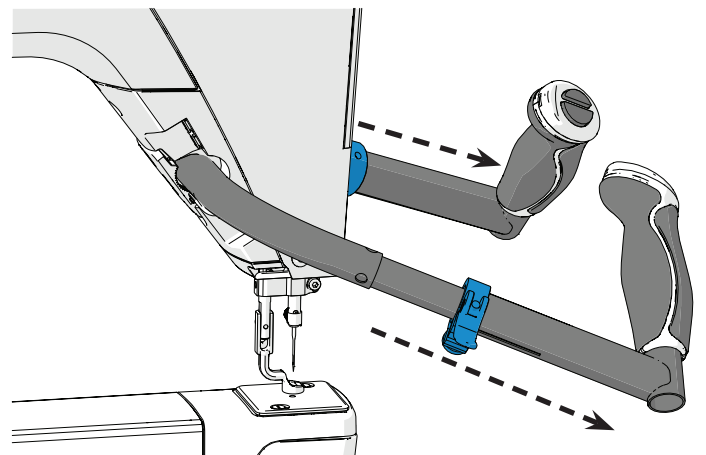

- 9 Once you are comfortable with the position of the handles, close the **handlebar levers**.

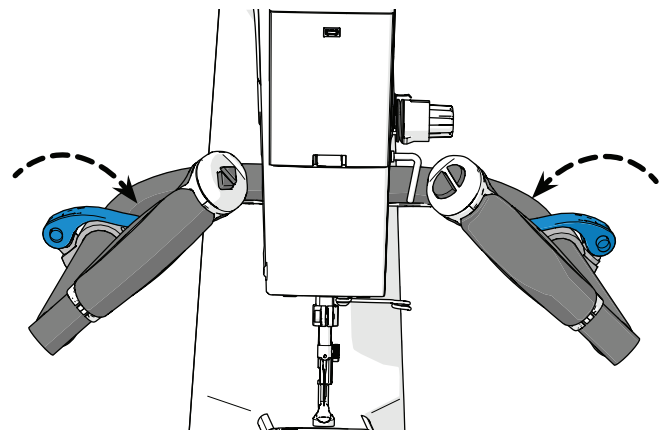

Part Three | Out of Box Assembly

Task 4 - Installing the Handlebars (Continued)

Tip: For micro-stippling, angle the handlebars down toward the fabric in step 5, and leave the controls horizontal in step 6.

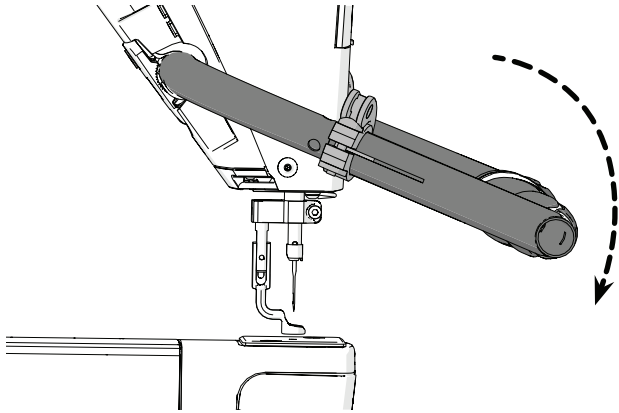

- 10 Plug the color-coded cables from the handlebars into the machine.

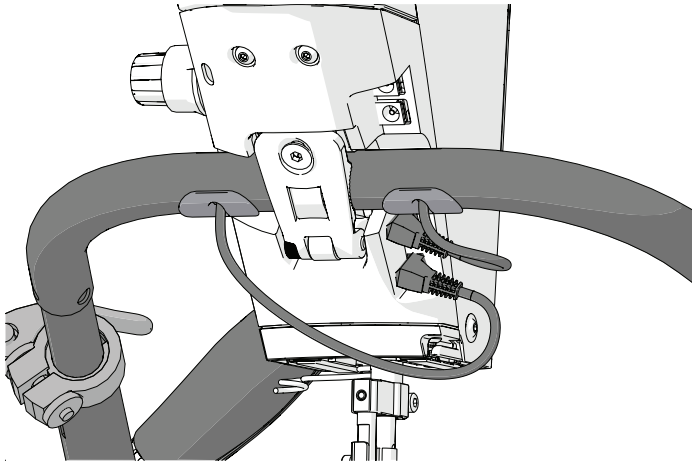

Task 5 - Connecting the Display

Parts & Tools Needed:

2.4-Inch Touch Display

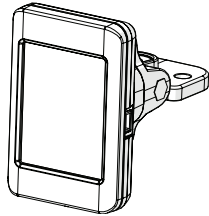

Display Box

SBHCS Screw
M5 x 16 mm (x2)

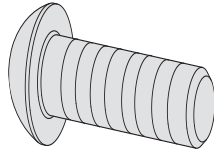

Display Box

T-handle Allen
Wrench 3 mm

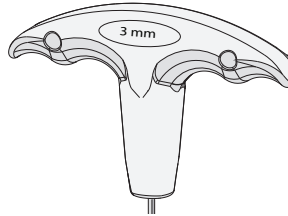

Tools Box

T-handle Allen
Wrench 2.5 mm

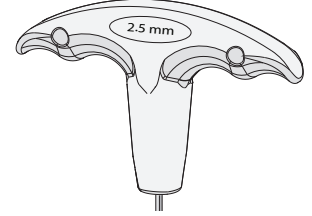

Instructions

Take the following steps to install the display.

- 1 The parts needed for this step are in the **display box**.

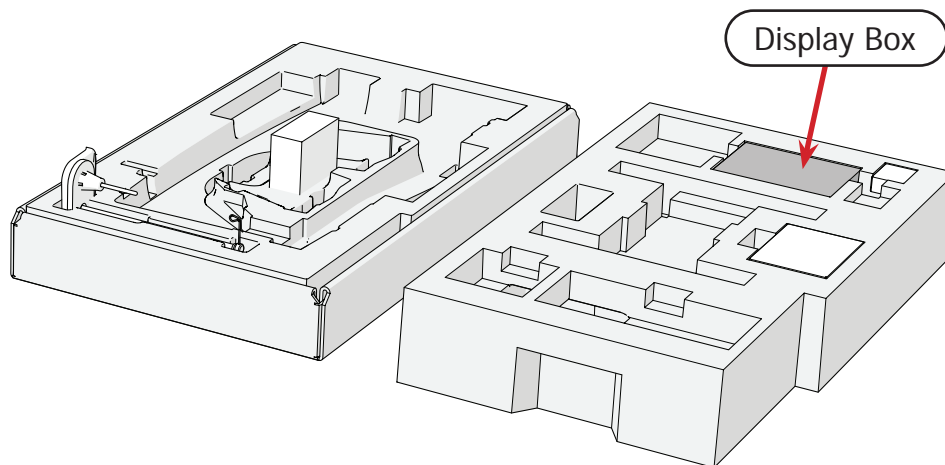

- 2 Use the 2.5 mm Allen wrench to remove the **M4 x 6 mm SBHCS** from the **front display cover** and remove the cover.

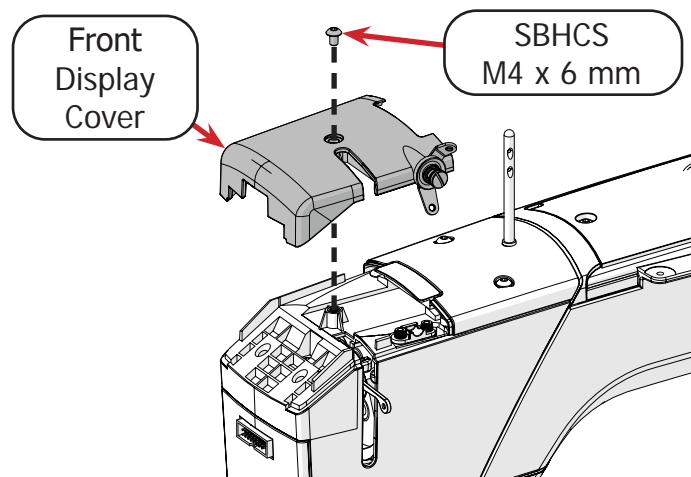

Part Three | Out of Box Assembly

Task 5 - Connecting the Display (Continued)

- 3 Attach the 2.4-inch touch display using two **M5 x 16 mm SBHCS** and the 3 mm Allen wrench.

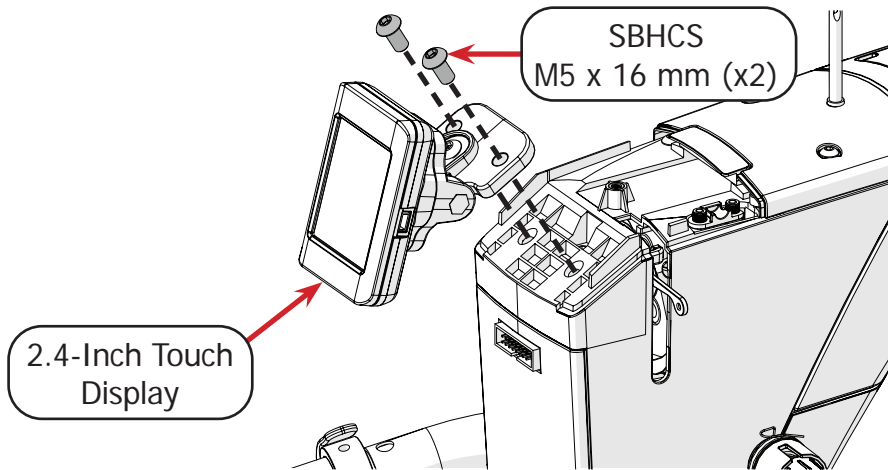

- 4 Replace the front display cover with the M4 x 6 mm SBHCS and the 2.5 mm Allen wrench.

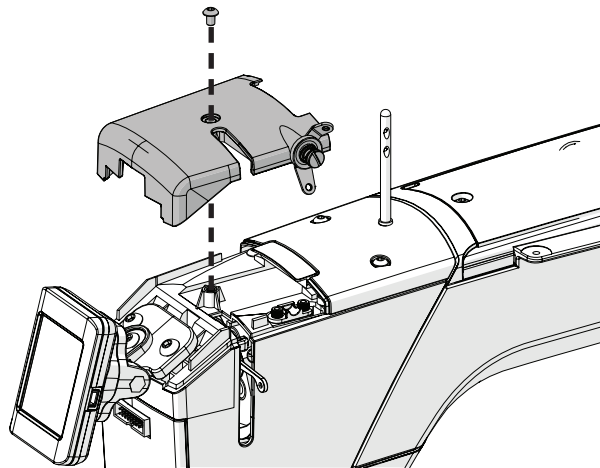

- 5 Plug the **display cable** into the cable port on the front of the machine.

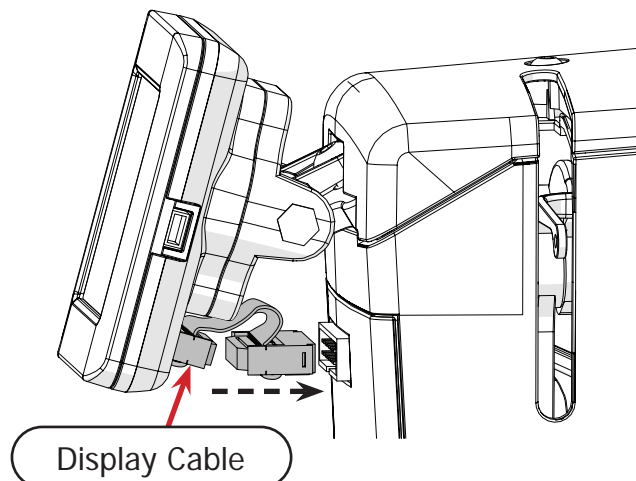

Task 6 - Attaching the Thread Stand

Parts & Tools Needed:

Thread Stand
Assembly

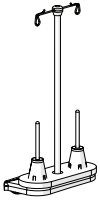

Bottom Level

SBHCS Screw
M4 x 8 mm (x2)

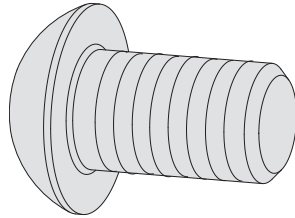

Thread Stand
Hardware Box

T-handle Allen
Wrench 2.5 mm

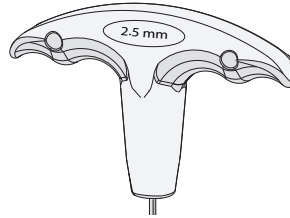

Instructions

Take the following steps to install the thread stand assembly:

- 1 Take the **thread stand assembly** out of the second level of packaging. The screws needed for this task are in the **thread stand hardware box**.

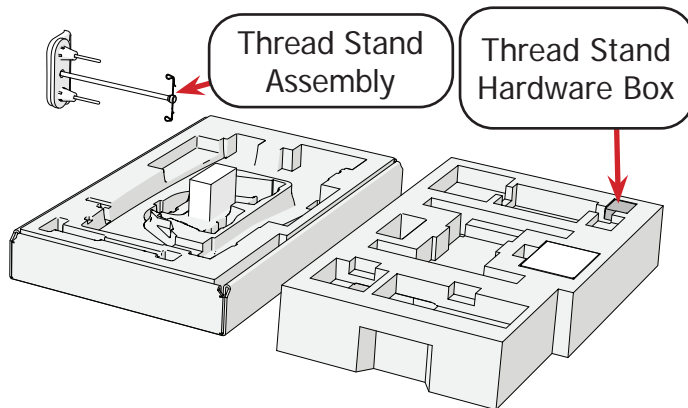

- 2 Slide the thread stand assembly over the screw holes on the small **lip** on the right side of the machine.

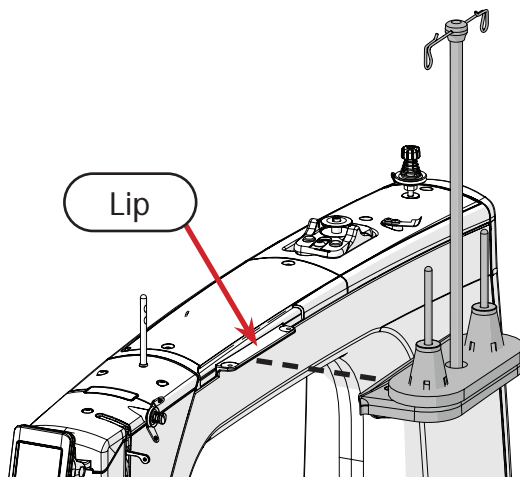

- 3 Secure the thread stand assembly in place using two **M4 x 8 mm SBHCS** and the 2.5 mm Allen wrench. You may need to lightly push the piece of **foam** aside to insert the screws.

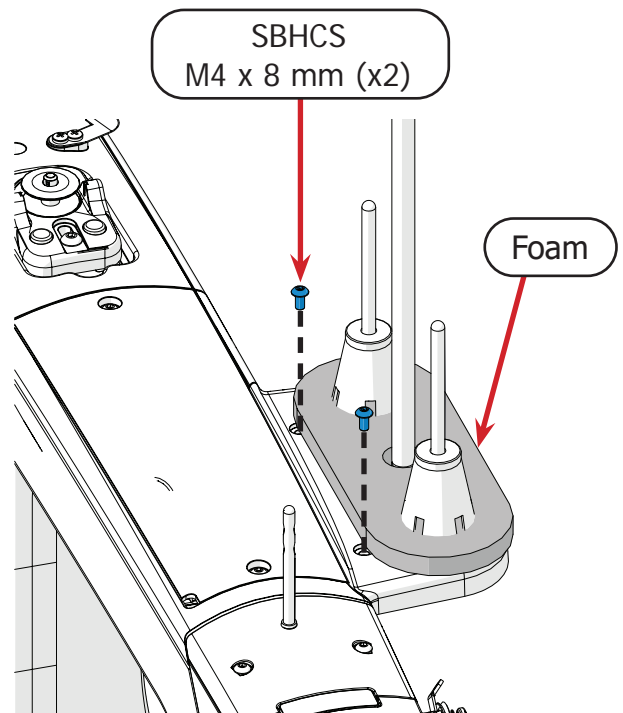

Task 7 - Installing the Upper Encoder

Parts & Tools Needed:

Upper Encoder
(silver spring)

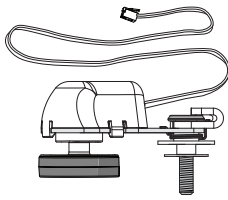

Encoder Box

T-handle Allen
Wrench 4 mm

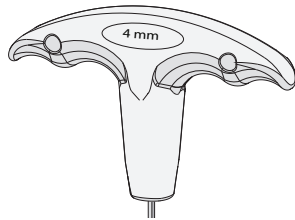

T-handle Allen
Wrench 2.5 mm

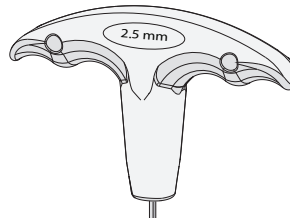

Instructions

The encoders monitor the position of the machine on the frame, allowing for regulated stitching. The upper encoder is installed on the outward-facing, left-rear wheel of the machine. Please take the following steps:

- 1 Use the 4 mm T-handle Allen wrench to remove the **left rear wheel** from the machine.

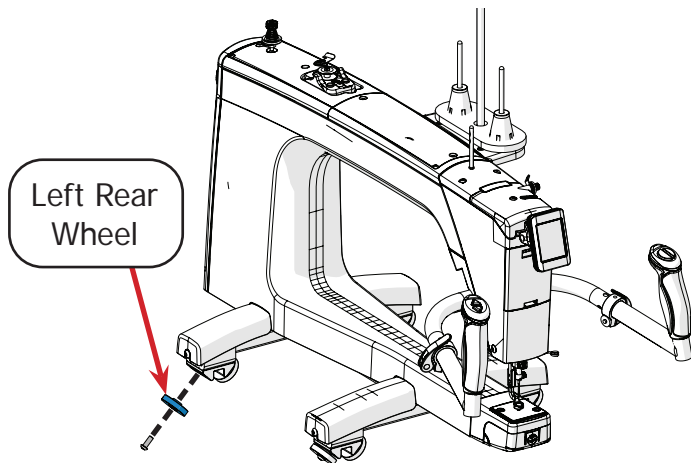

The **wheel screw** will not be needed again and can be stored with the packaging materials.

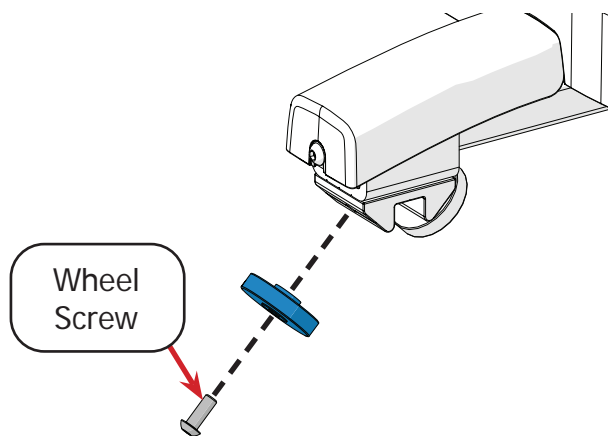

- 2 Find the **upper encoder** in **box 2**. The upper encoder has a silver spring and a purple sticker on the cable.

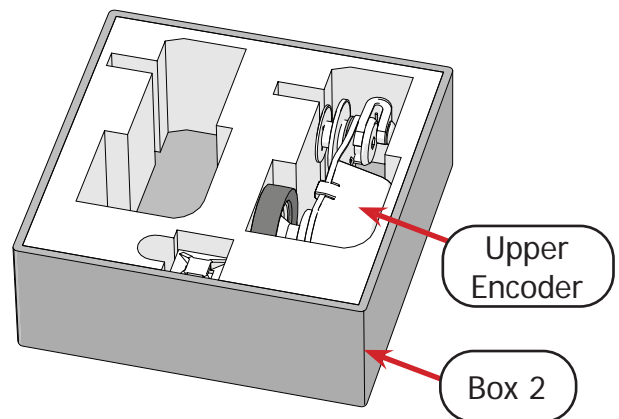

- 3 Loosen the **lock collar screw** on the upper encoder with the 2.5 mm Allen wrench until the **lock collar** (shown in blue) turns freely.

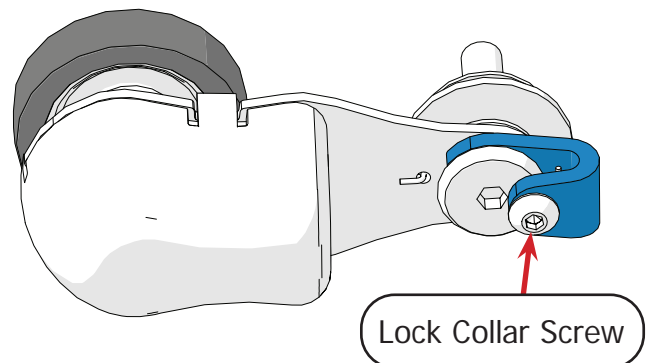

- 4 Slide the wheel onto the upper **encoder screw** so that the **wheel hub** faces away from the encoder.

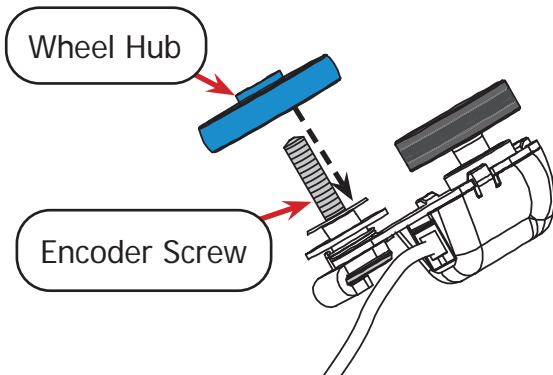

- 5 Place the encoder screw into the left rear wheel hole so the **dark encoder wheel** is between the two left machine wheels.

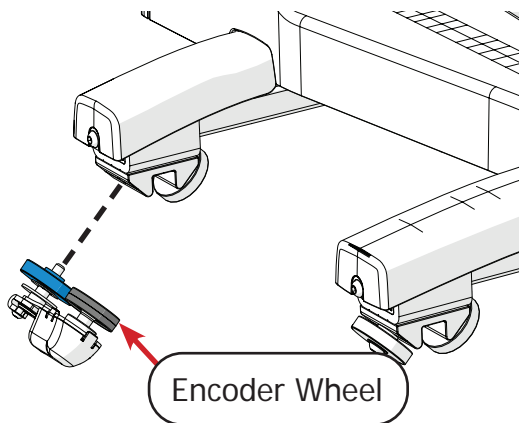

- 6 Tighten the **encoder screw** with the 4 mm Allen wrench.

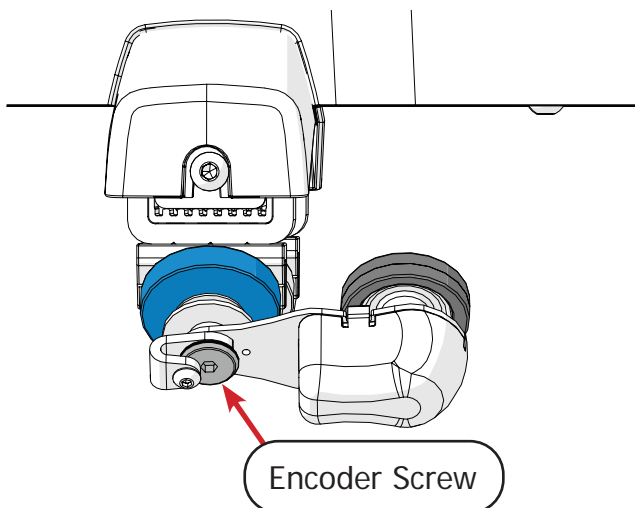

- 7 Turn the **encoder lock collar** (shown in blue) to point up and tighten the **lock collar screw** with the 2.5 mm Allen wrench.

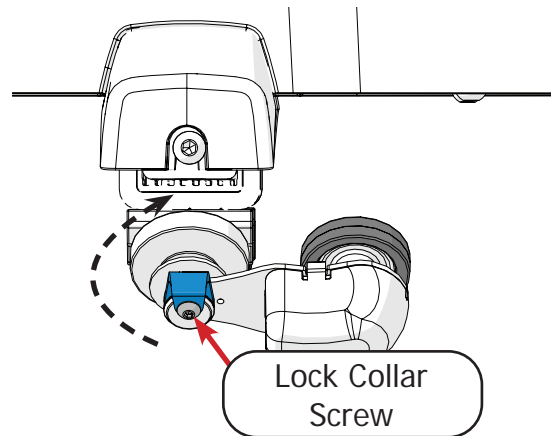

- 8 Plug the upper encoder cable into the **purple encoder port** on the back left of the machine.

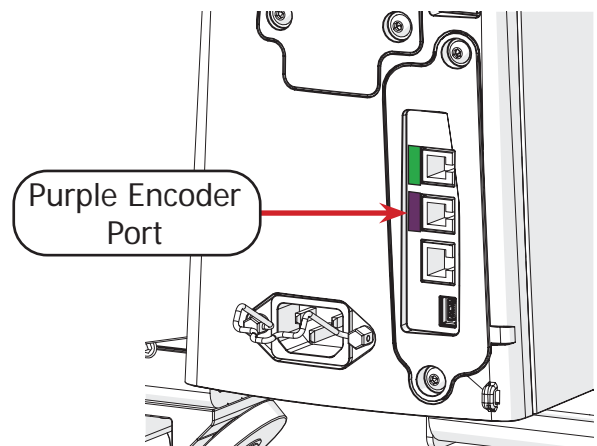

- 9 Plug the lower encoder cable into the **green encoder port** on the left rear of the machine.

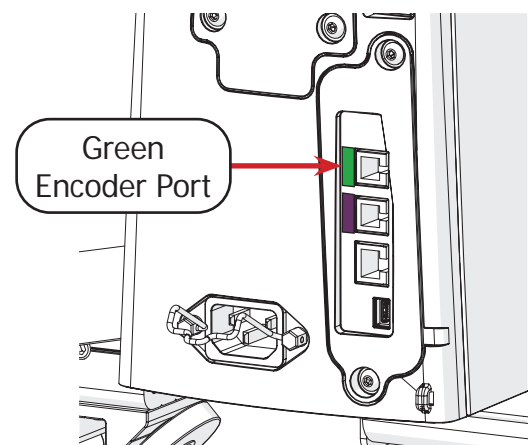

Task 8 - Turning the Machine On/Off

Parts & Tools Needed:

Power Cord

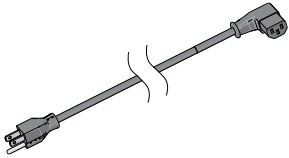

Power Cord/Oil Bottle
Box

Instructions

The power cable port and power switch are located on the back of the machine. To power on the machine, take the following steps:

- 1 Find the power cord in the **power cord/oil bottle box**.

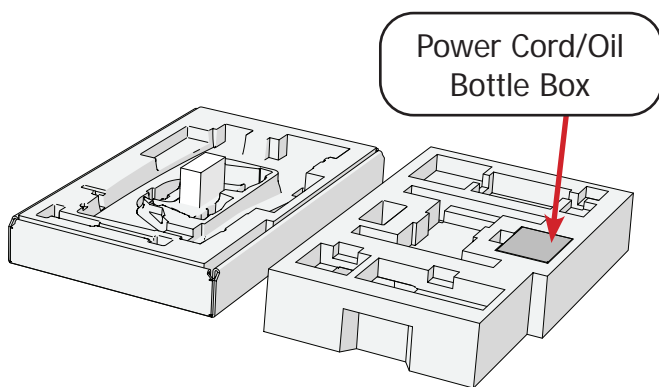

- 2 Lift up the **power cable retainer** (blue) and plug the **power cord** into the back of the machine.

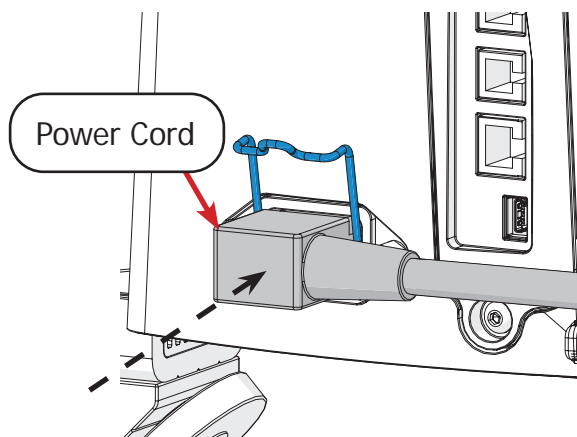

- 3 Press the **power cable retainer** down firmly until it grasps the power cable.

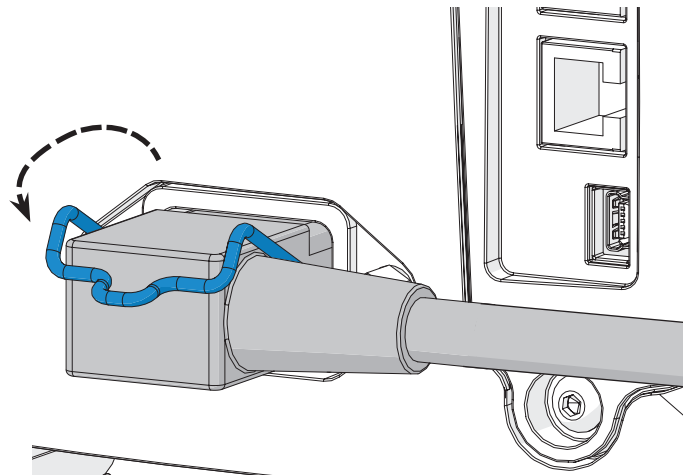

- 4 Press the **power switch** up to turn the machine on.

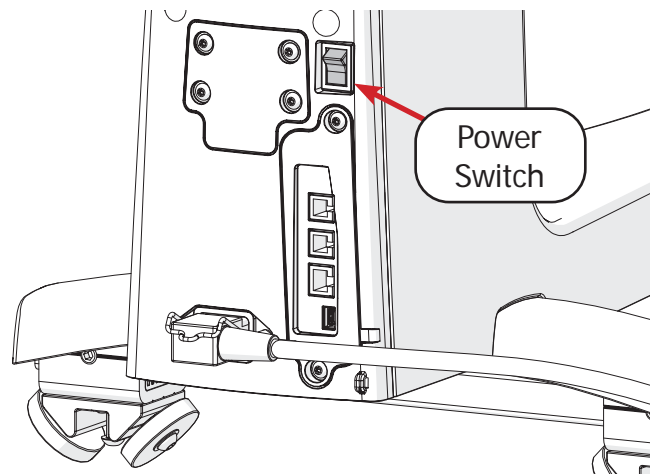

Preparing to Quilt

This section of the manual covers winding the bobbin, loading the bobbin case, and threading the machine.

Task 9 - Winding a Bobbin	page 29
Task 10 - Loading the Bobbin Case	page 32
Task 11 - Threading the Machine	page 34

Task 9 - Winding a Bobbin

Parts & Tools Needed:

Bobbin (Class M)

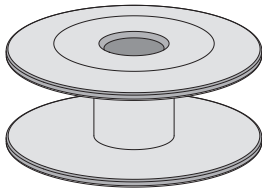

Box 1

T-handle Allen Wrench
3 mm (optional)

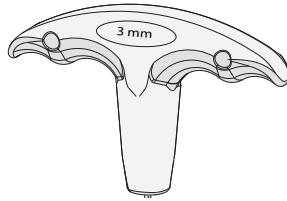

Winding Instructions

Your machine comes with two bobbins pre-wound with 50 weight polyester Finesse thread. An empty M-class bobbin has also been provided. It's important to choose bobbin thread that is similar in type and quality as the top thread. For more information on choosing thread, see "Choosing Your Thread" on page 96.

Note: This machine uses cone-style thread. Unless you have the spool accessory, please use only thread cones for this machine.

The following diagram outlines the path the thread (shown in blue) must take to wind the bobbin.

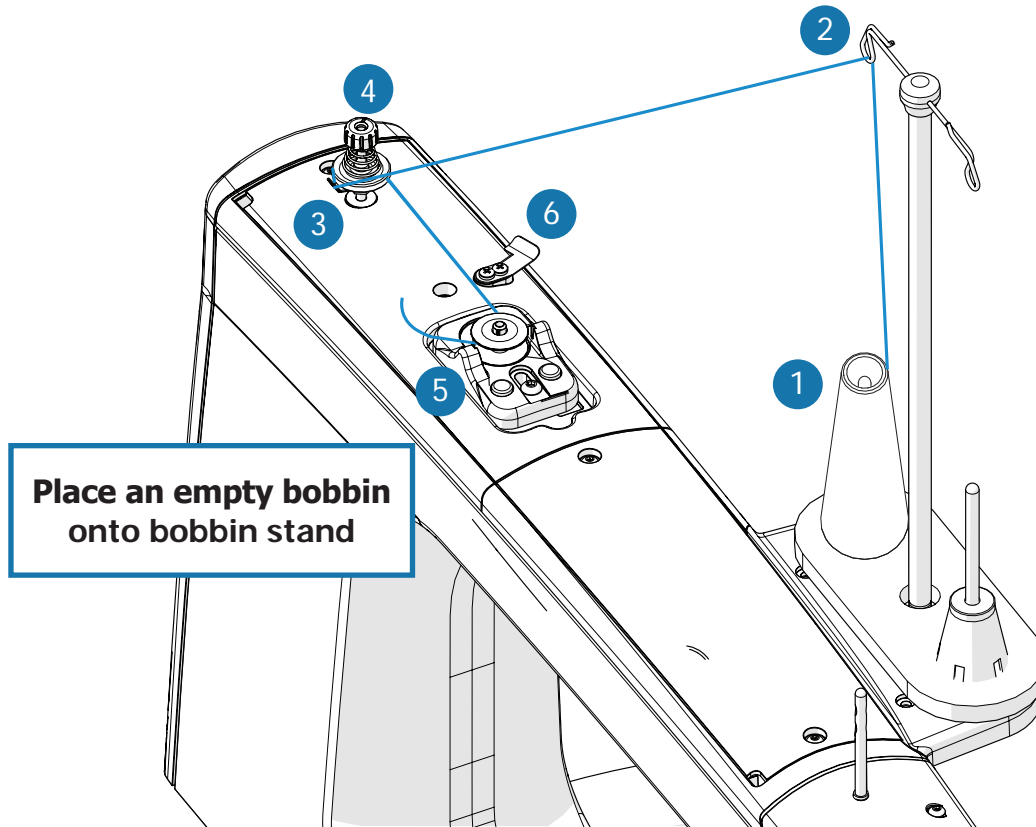

1 Thread Stand

3 Tensioner Thread Guide

5 Bobbin Stand with Bobbin

2 Guide Loops

4 Bobbin Thread Tensioner

6 Thread Cutter

- 1 Run the thread through the **thread mast guide loop** directly above the thread cone.

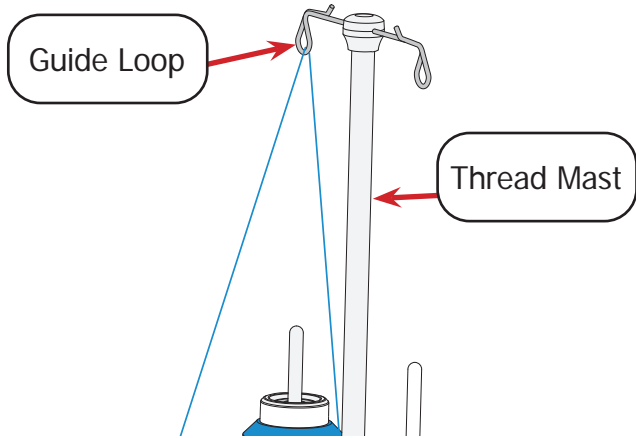

- 2 Pull the thread through the hole in the tensioner **thread guide** and then around the back of the **bobbin thread tensioner**, between the two discs.

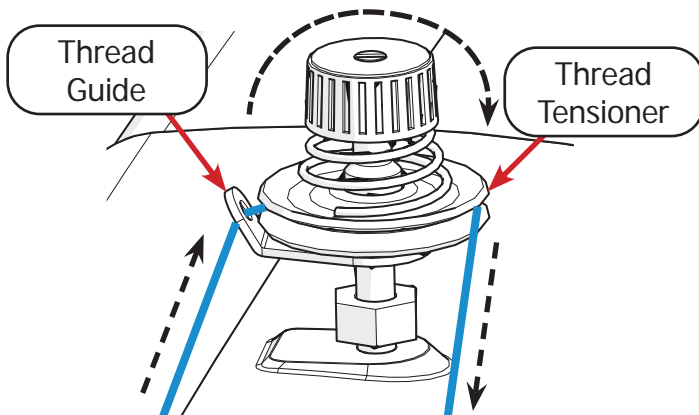

- 3 Tightly wrap the thread clockwise around the bobbin a few times to hold the thread in place. Push the **start button** toward the bobbin to start winding.

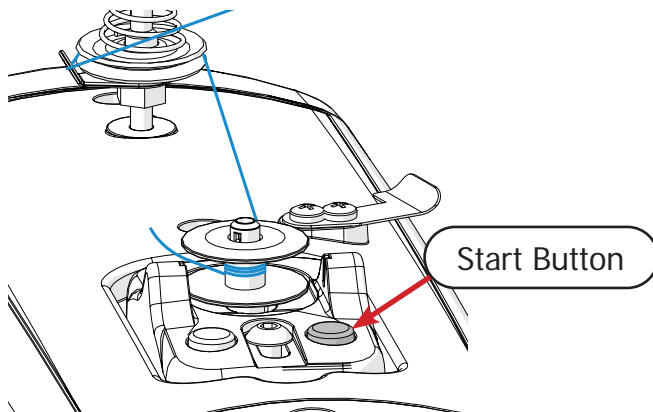

- 4 Winding stops automatically when the bobbin is full, or you can press the **stop button** to stop winding. Remove the bobbin from the bobbin winder and cut the thread with the **thread cutter**

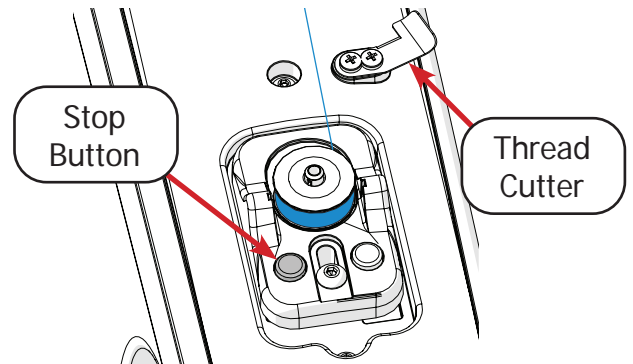

The bobbin thread should appear neat and smooth.

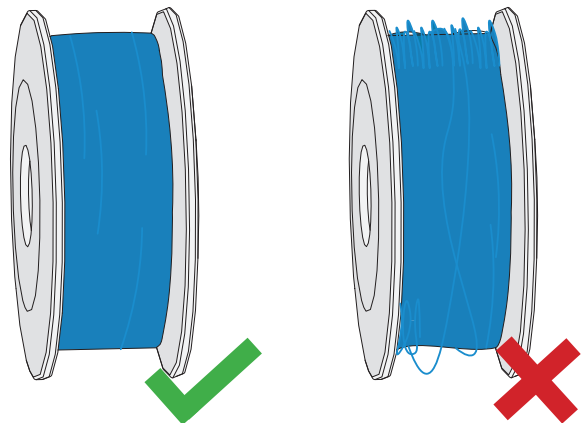

Task 9 - Winding a Bobbin (Continued)

Adjust Fill Levels

The bobbin winder can be adjusted to fill a bobbin to different levels if desired.

- 1 To adjust the bobbin winder, loosen the **M5 x 16 mm SBHCS** with the 3 mm Allen wrench.

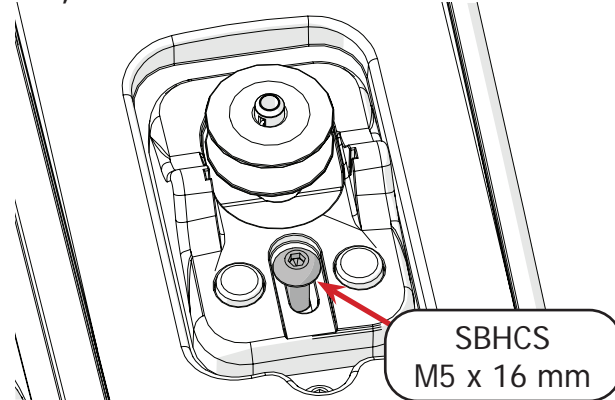

- 6 Slide the bobbin winder until the **guide line** underneath the bobbin is positioned where you want the bobbin thread to finish filling.

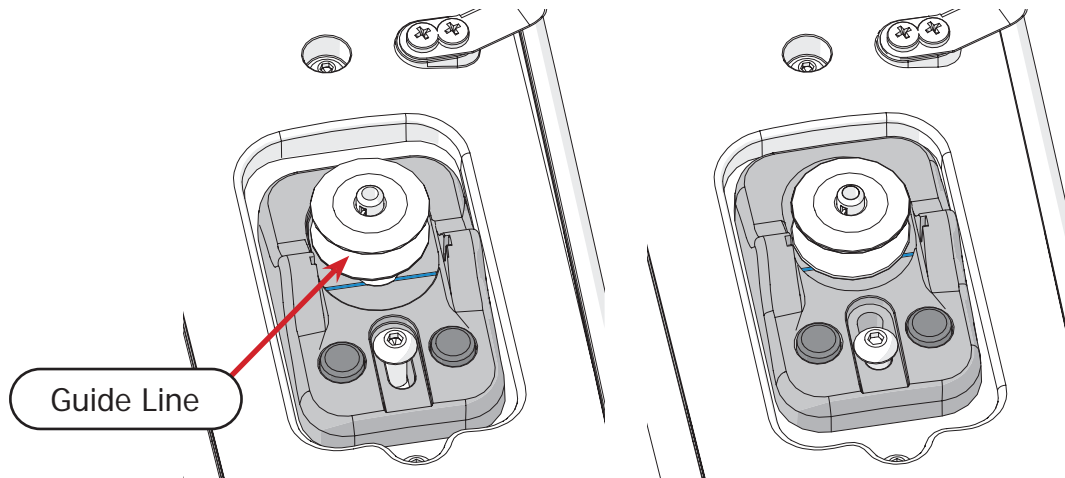

- 7 Tighten the M5 x 16 mm SBHCS to secure the bobbin winder in place.

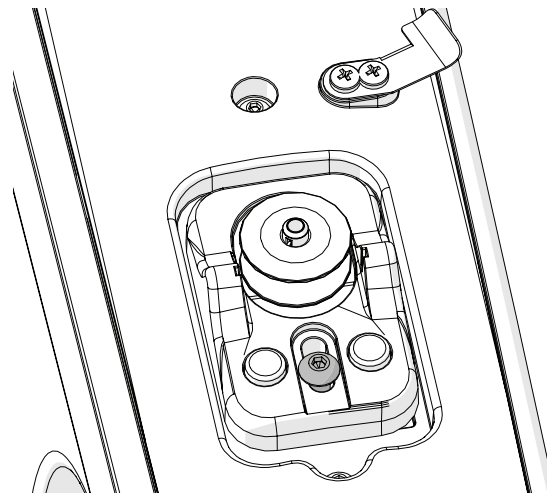

Task 10 - Loading the Bobbin Case

Take the following steps to insert the wound bobbin into the bobbin case and place it in the machine:

- 1 Check that the needle is up. If needed, rotate the **hand wheel** to raise the needle.

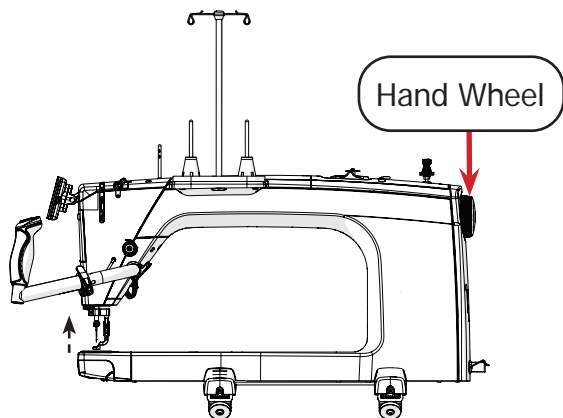

- 2 Open the Tools menu by clicking the icon in the top left corner. This prevents accidental stitching.

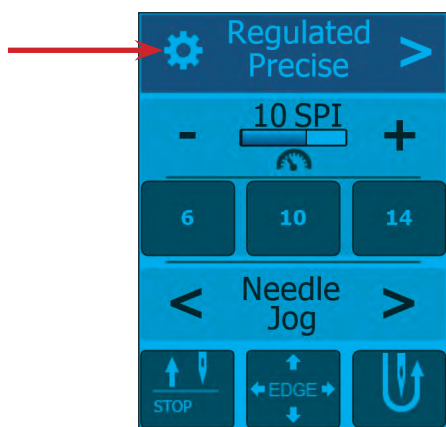

- 3 Pull on the bobbin case **release lever** to remove the bobbin case from the hook assembly.

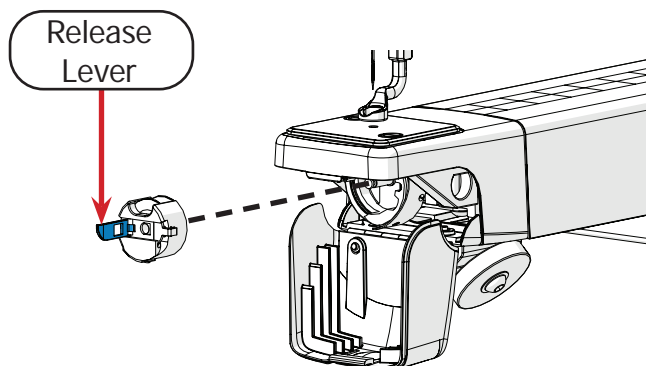

- 4 Place the wound bobbin into the **bobbin case**. Note the direction that the thread is coming off the bobbin in relation to the case.

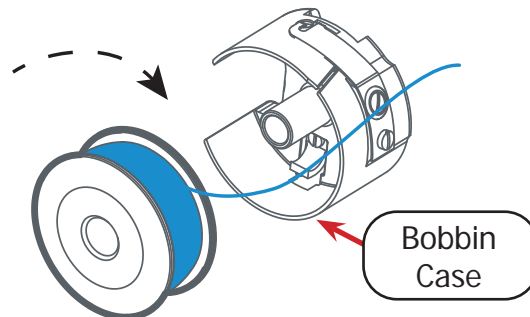

- 5 Slip a few inches of thread through the **slot** and out of the **hole**.

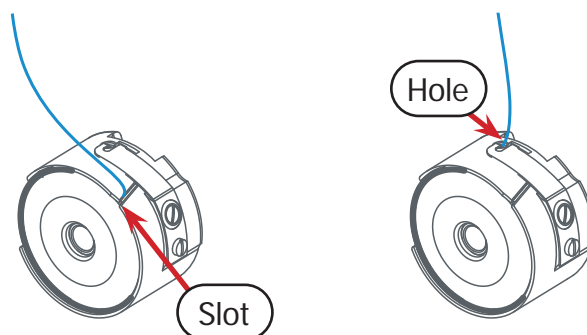

Note: If the bobbin is wound correctly it will turn clockwise when the thread is pulled.

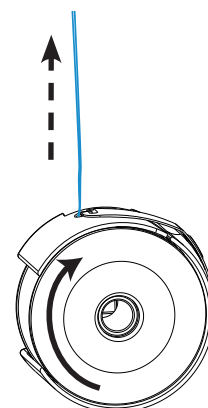

Task 10 - Loading the Bobbin Case (Continued)

6 Test the tension of the bobbin case every time bobbin thread is changed; bobbin tension is the foundation for correct thread tension.

a. Place the bobbin case flat on its side, on your palm.

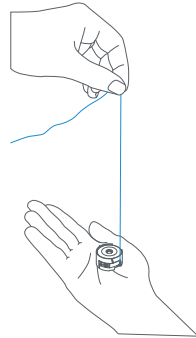

b. Pull up on the thread. The thread should run freely and the bobbin case should rise into a vertical position without lifting off your hand.

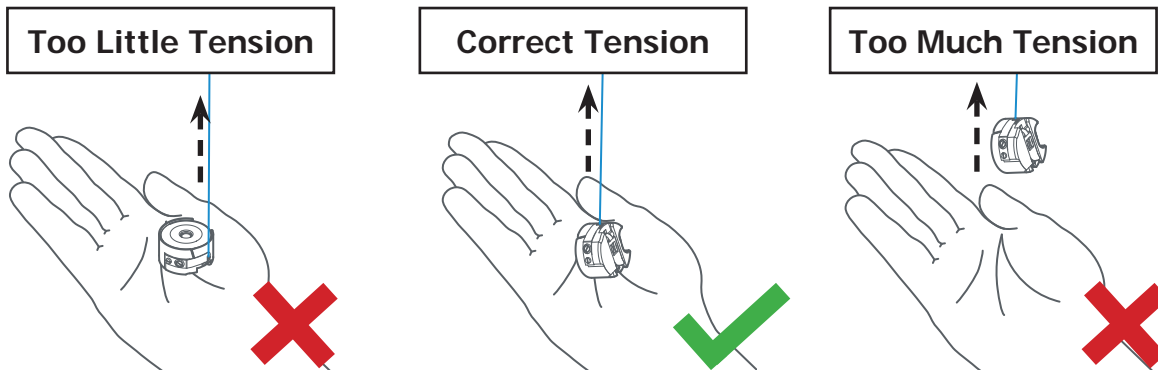

- If the case remains on its side, there is too little tension. Turn the **large screw** clockwise.
- If the case lifts into the air, there is too much tension. Turn the **large screw** counter-clockwise.

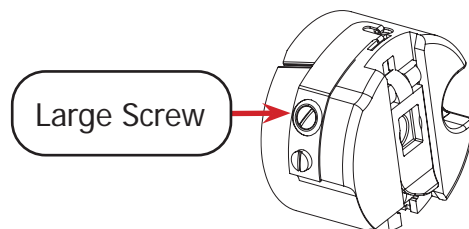

7 Place the bobbin case inside the machine with the **lever** (shown in blue) at the 3 o'clock position. It should click into place. Do not pull on the lever while inserting the bobbin case.

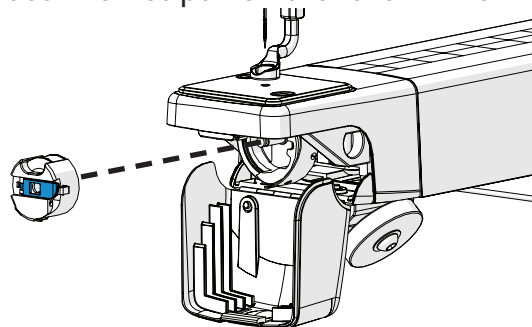

Task 11 - Threading the Machine

Before threading the machine, make sure you've selected quality thread for your project. Choosing the right thread for the machine can prevent the thread from breaking or tangling up under the needle plate. For more information on choosing thread, see page 96. Note the following:

- This machine uses cone-style thread, not thread from a spool. Do not use spool thread unless the spool accessory (not included in this kit) has been installed.



- Choose thread that is strong enough to pass the yank test (shown below), and re-test thread as it ages. Thread strength can diminish over time.
 - a. Hold the cone in one hand and the end of thread in the other.

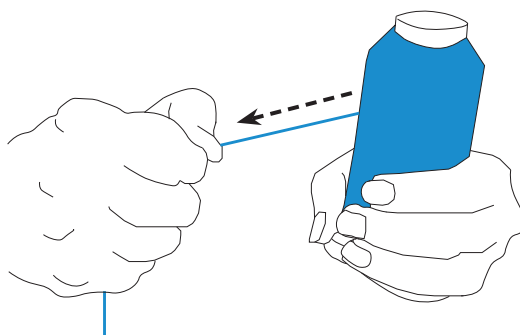

- b. Tug on the thread. If the thread snaps easily, it may be too brittle to use for quilting.

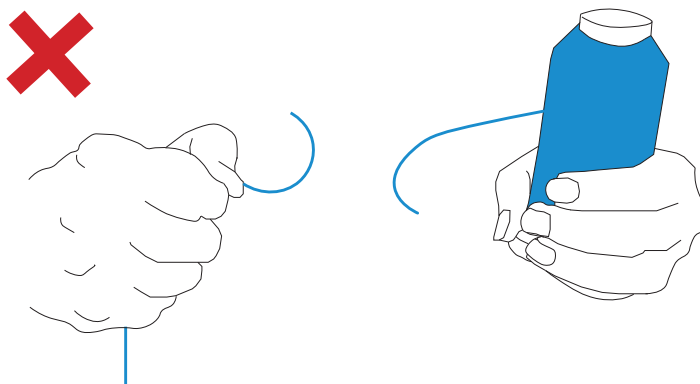

Part Three | Preparing to Quilt

Task 11 - Threading the Machine (Continued)

The following diagram outlines the path the thread (shown in blue) must take through the machine.

- 1 Thread Cone
- 2 Thread Mast Guide Loop
- 3 Thread Guide Rod
- 4 Small Thread Tensioner
- 5 Large Thread Tensioner
- 6 Check Spring
- 7 Thread Guide
- 8 Take-up Lever
- 9 Bottom Thread Guide
- 10 Needle Bar Eyelet
- 11 Eye of Needle

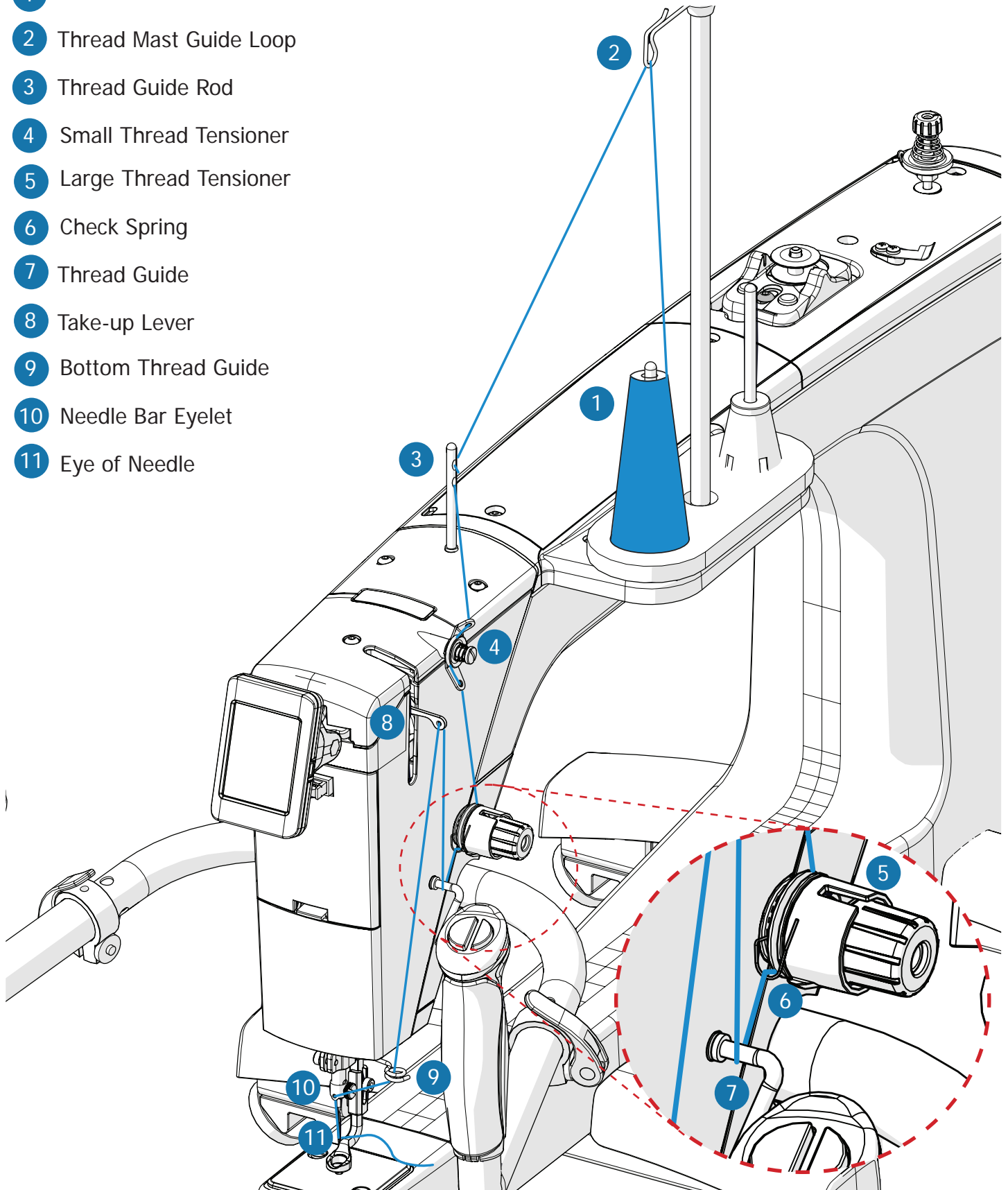

- 1 Rotate the **hand wheel** at the rear of the machine to raise the needle to the top position

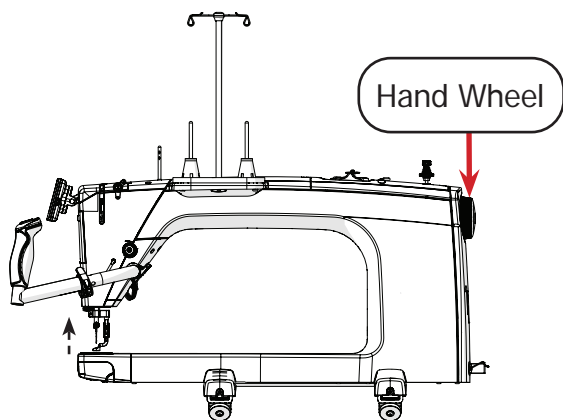

- 2 Open the Tools menu by clicking the icon in the top left corner. This prevents accidental stitching.

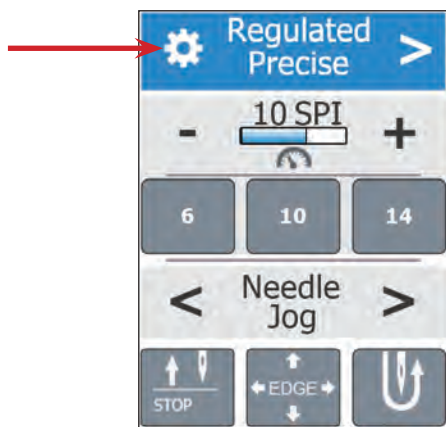

- 3 Place the thread cone on the cone-style **thread stand** toward the front of the machine.

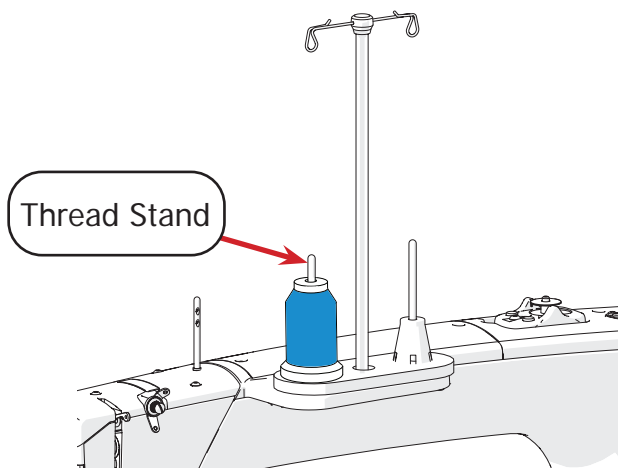

- 4 Pull the thread straight up, through the **thread mast guide loop** above the thread stand.

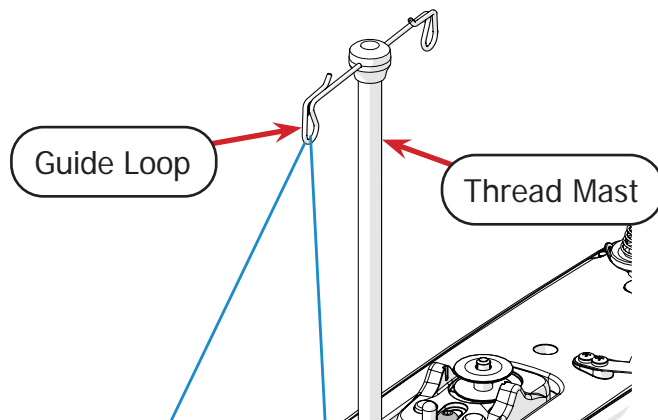

- 5 Feed the thread through the top hole of the **thread guide rod**. Wrap the thread around to the back of the guide and insert through the bottom hole.

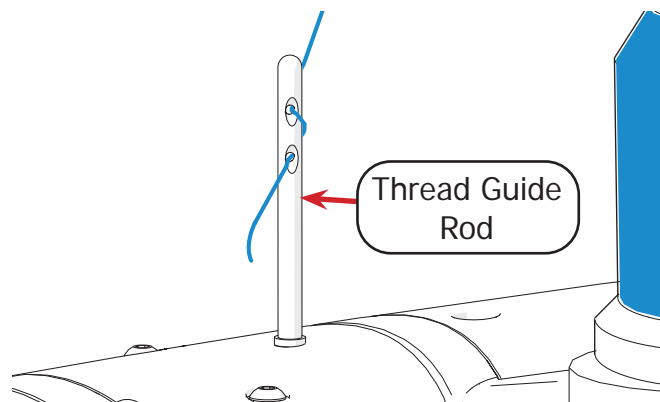

- 6 Run the thread through the top hole on the **small thread tensioner**. Then slip the thread between the two discs, and through the bottom hole of the small thread tensioner.

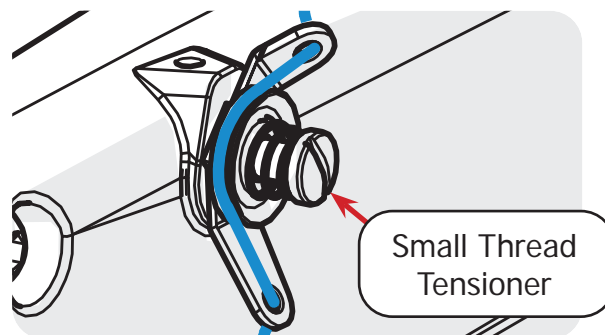

- 7 Pull the thread around the **large thread tensioner**, between the tension discs.

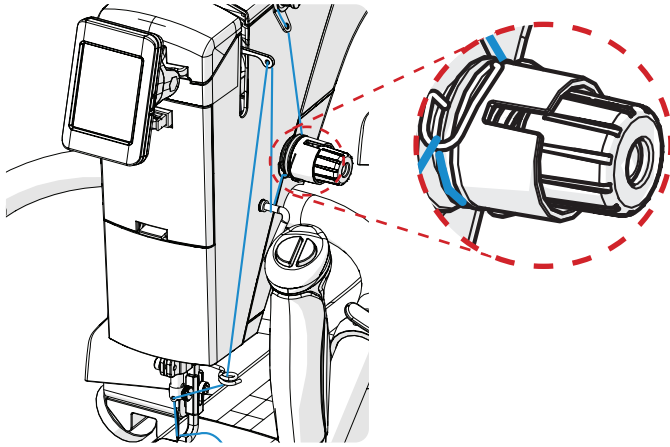

- 8 Wrap the thread over the **check spring**.

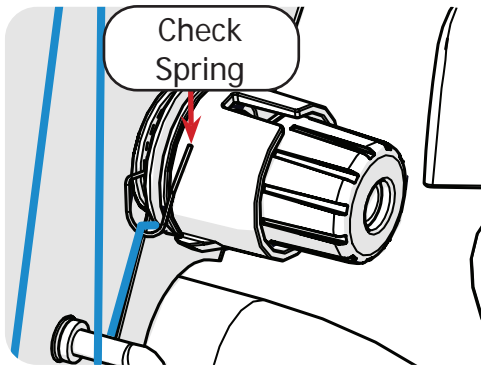

- 9 Next, pass the thread down and around the **thread guide** next to the large thread tensioner.

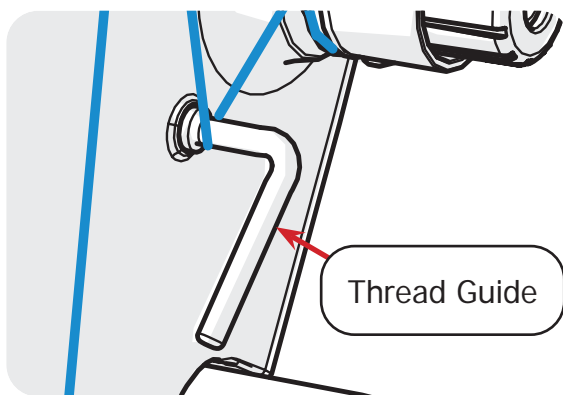

- 10 Pull the thread through the hole in the **take-up lever**.

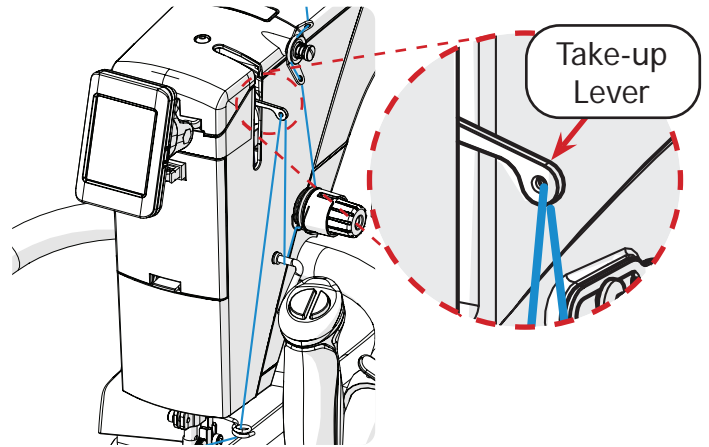

- 11 Then pass the thread down through the **bottom thread guide** on the way to the needle.

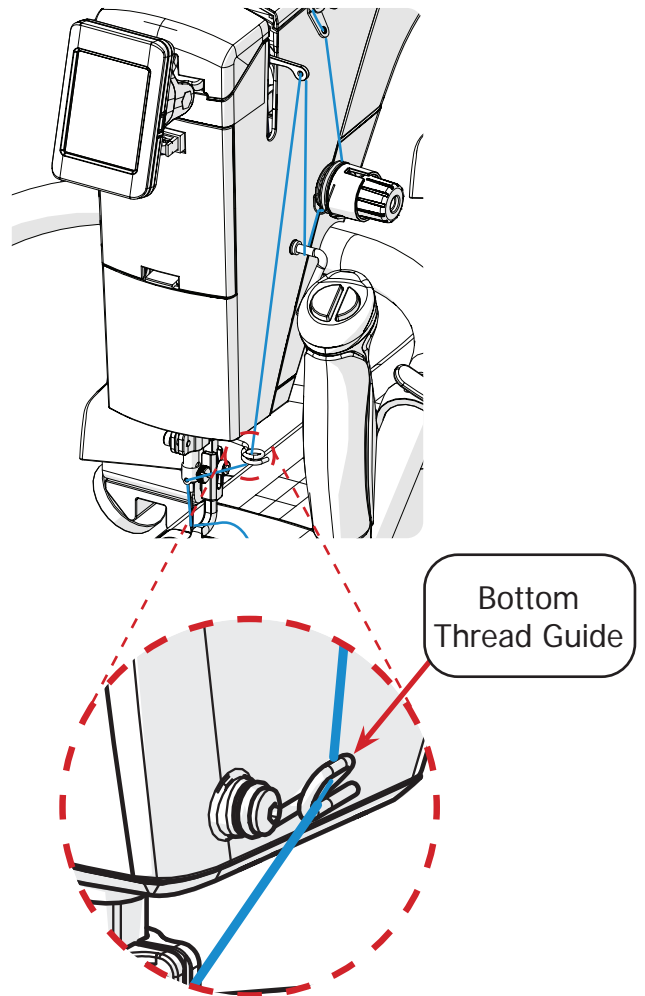

- 12 Now pass the thread through the front of the **needle bar eyelet**, located above the needle. Thread the **eye of the needle** from front to back.

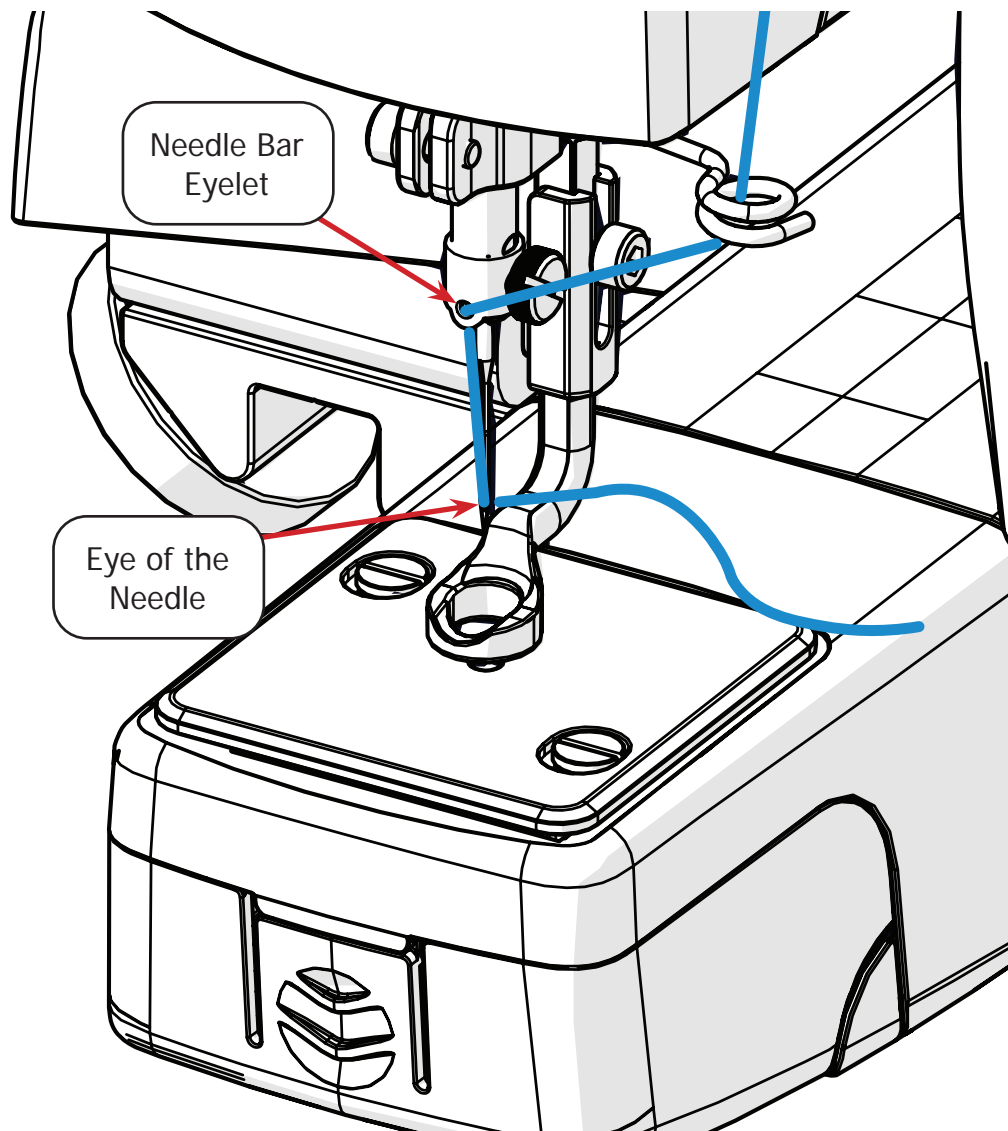

- 13 Cut the excess thread with the built-in **thread cutter** on the side of the hopping foot opposite the small thread guide.

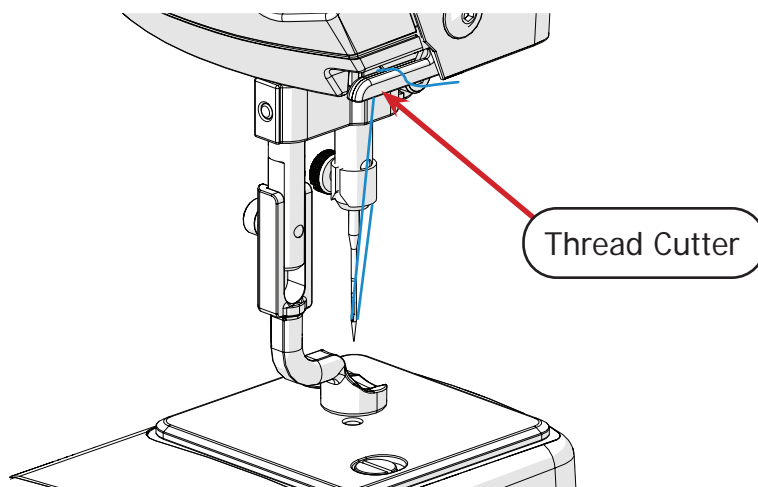

Congratulations! You have completed Part Three of this manual.

If you are assembling a new frame, turn to Part Three of your frame manual. If your frame manual is not broken into parts, follow the manual's directions to:

- Install and adjust the rails
- Install frame handwheel (if applicable)
- Install the bungee clamps (if applicable)
- Adjust the carriage stop (Cutie Frame only)
- Level the frame

If you are not assembling a new frame but are installing QuiltMotion onto your frame, turn to Part Three of your QuiltMotion manual.

If you are installing your machine onto a frame that is already fully assembled and are not installing QuiltMotion at this time, continue to Part Four of this manual on page 40.

Part Four

If your frame isn't fully assembled at this time, it is recommended to complete Part Three in your frame manual, Part Three in your QuiltMotion manual (optional), and Part Four of your frame manual before you continue.

Progress Checkpoint:

Have you:

- Installed your frame's rails.
- Adjusted the rails to work with your machine.
- Installed frame handwheel (applicable frames only)
- Installed bungee clamps (applicable frames only)
- Adjusted the carriage stop (Cutie Frame only)
- Leveled the frame (applicable frames only)

Have you:

- Completed QuiltMotion Part Three (optional)

Have you:

- Prepared your frame for fabric installation
- Installed your quilt onto your frame

Quilting

This section of the manual covers how to use the handlebar controls, the different quilting modes, and tools on the display.

Choosing Machine Settings	page 42
Using Machine Handlebar Controls	page 44
Using Precise Quilting Mode	page 45
Using Cruise Quilting Mode	page 47
Using Manual Quilting Mode	page 49
Using Baste Quilting Mode	page 51
Screen Settings	page 53
Using the Edge Warning	page 54
Adjusting Thread Tension	page 57
Taking Measurements	page 60
System Info	page 62
Getting Started	page 63

Choosing Machine Settings

To customize the settings for the handlebar controls, screen buttons, or warning icons, take the following steps:

- 1 Press the menu icon in the top right corner of the screen and select **Machine Settings**.

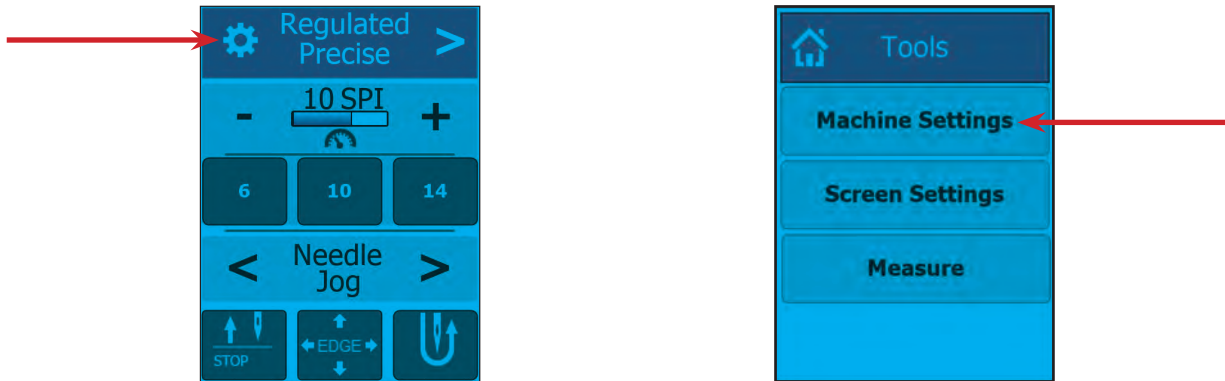

The Machine Settings menu opens.

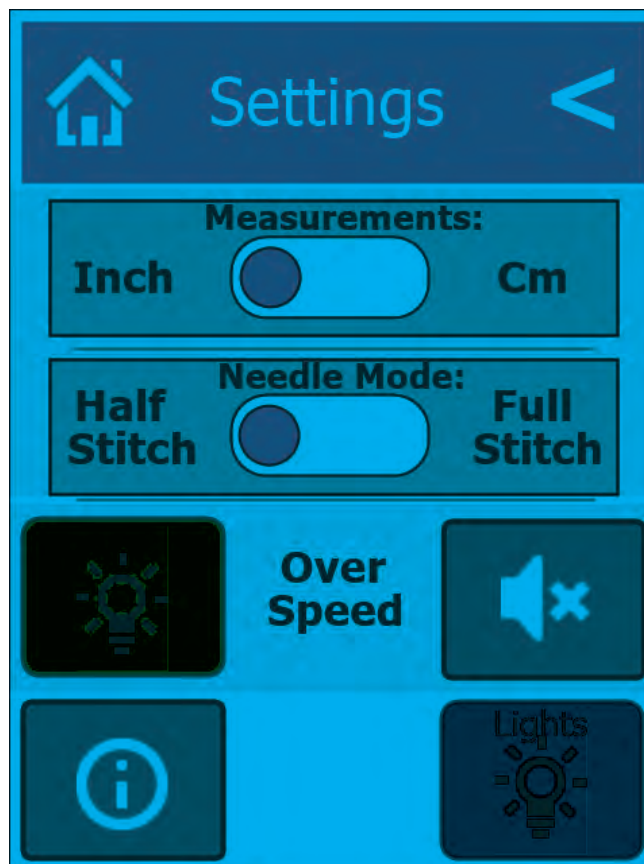





Note: The machine is unable to stitch while the Tools or Settings menu is pulled up.

Part Four | Quilting

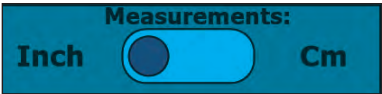
Choosing Machine Settings (Continued)

2 Choose desired settings:

	Choose to display machine stitch length in stitches per inch or stitches per centimeter.
	Choose whether the needle button on the quilting mode screens and handlebar controls will create a full or a half stitch.
	The overspeed alarm and overspeed warning light can each be deactivated so that they will not turn on if the machine is moved more quickly than regulated stitching can manage.
	Press to turn the lamp above the needle area on or off.

3 Press the **information** icon to access the System Info screen. This displays the firmware versions for your machine (see page 62) as well as the stitch count and run-time for a current project and the life of your machine.

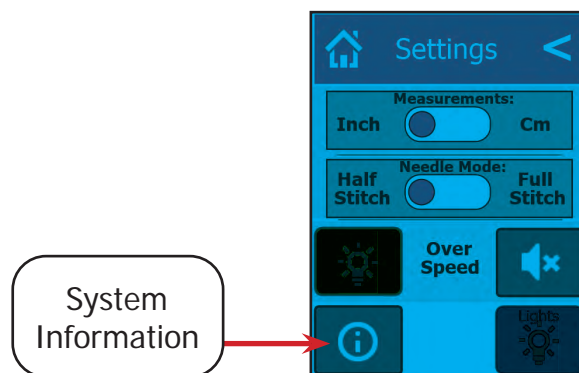

4 Click the home icon to return to the **quilting screen**, or back to return to the **tools menu**.

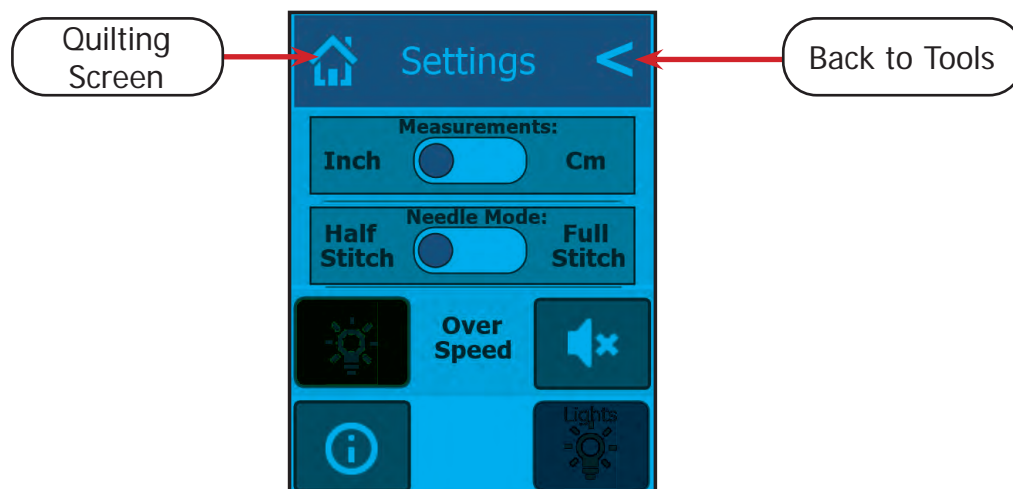

Using the Handlebar Controls

When first powered up, the machine is in regulated precise quilting mode (see page 45) and can start quilting right away. Please take a moment to review the handlebar controls. These controls are used when quilting. While in the Settings menu, some buttons have a different purpose or do not function (see “Choosing Machine Settings” on page 42 for details).

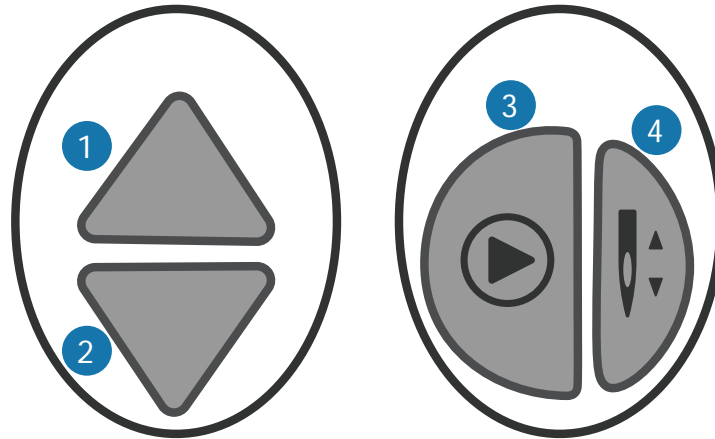

- 1 **Increase:** This button increases the number, size, or speed of the stitching, depending upon the quilting mode. For example, in precise quilting mode, this button will increase the number of stitches the machine makes in an inch (SPI) or in a centimeter (SPC).
- 2 **Decrease:** This button will decrease the number, size, or speed of the stitching depending upon the quilting mode.
- 3 **Start/Stop Quilting:** Press to start or stop stitching.
- 4 **Needle Button:** Press to create a single stitch or to toggle the needle between the up and down positions, based upon settings (see “Choosing Machine Settings” on page 42 for details).

Using Precise Quilting Mode

The machine defaults to precise quilting mode when turned on. In this regulated quilting mode, you select the stitch length you want and the machine will adjust to help make more consistent stitches as you move the machine faster or slower or change direction. It will only stitch when you move the machine, which helps with patterns that have corners or crisp points.

To switch to precise mode, press the **select quilting mode** button to cycle through the four quilting modes until you reach **Regulated Precise**.

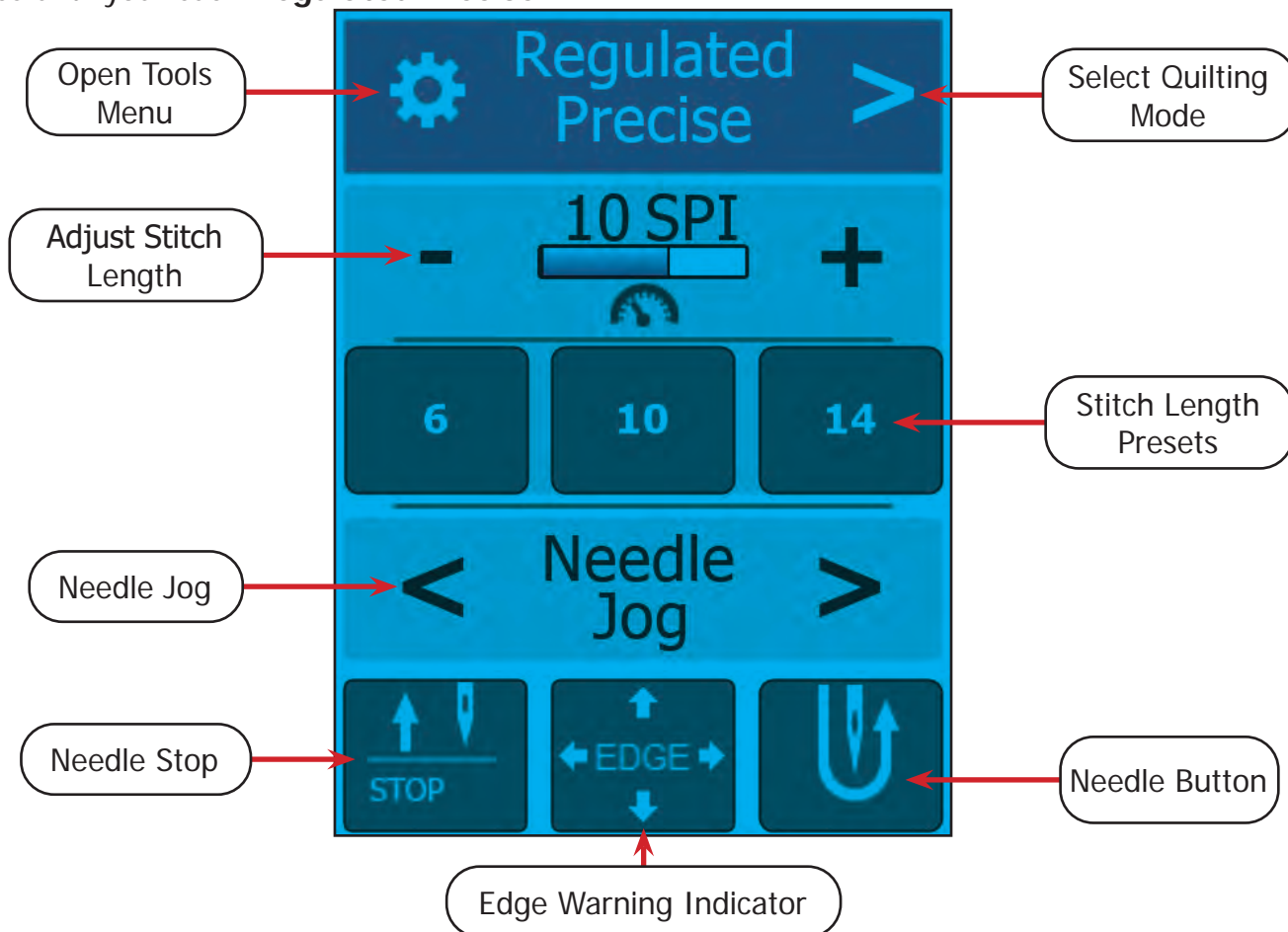

To quilt in regulated precise quilting mode, take the following steps:

- 1 Confirm that the **stitch length**, measured in stitches per inch or stitches per centimeter, is the desired length.

Note: The unit of measurement can be changed in the **Machine Settings** menu (see page 42).

Use the **-** **+** symbols to adjust the stitch length. A higher SPI or SPC means shorter stitch length.

- 2 When stitching is inactive, press the needle button on the display to make single or half stitches. This can also be done with the needle button on the right handle. To switch the type of stitch between a half stitch or full stitch, go to the Machine Settings menu (see page 42).

Note: While stitching is active, the needle buttons on the display and the handlebar controls are disabled.

- 3 Position the quilting machine over the quilt. If needed, use the **needle jog** buttons to move the needle closer or farther from the fabric in small increments to help place your first stitch.



Press to move the needle up or down in small increments.

- 4 Moving the machine too quickly while quilting can reduce the quality of the stitch regulation. If the machine is moved too quickly, the overspeed alarm will sound and a red LED light will shine on the needle area. Slow the machine's movement to turn off the alarm and light. Both the alarm and light can be deactivated in the **Machine Settings** menu.
- 5 When activated, the arrows on the **edge warning indicator** on the bottom of the quilting mode screen will turn green.



For instructions on how to use the edge warning alert, see page 54.

- 6 You may find that you need to take measurements while you quilt. Press the **tools menu** button and select **measure** to open the measure tool. For instructions on how to use the measure tool, see page 60.
- 7 To deactivate stitching, press the start/stop quilting button on the handlebars. The needle will move into the needle stop position indicated by the **needle stop** button on the bottom of the quilting mode screen. Press the needle stop button to set the needle to stop in either the up or down position.

Using Cruise Quilting Mode

Cruise mode is another regulated mode. You select the stitch length you want and the machine will adjust to help make more consistent stitches as you move the machine faster or slower or change direction. However, the machine will continue to stitch in place (at the minimum speed) if you stop moving the machine. This mode is helpful for continuous, smooth, or curvy designs.

To switch to cruise quilting mode, press the **select quilting mode** button to cycle through the four quilting modes until you reach **Regulated Cruise**.

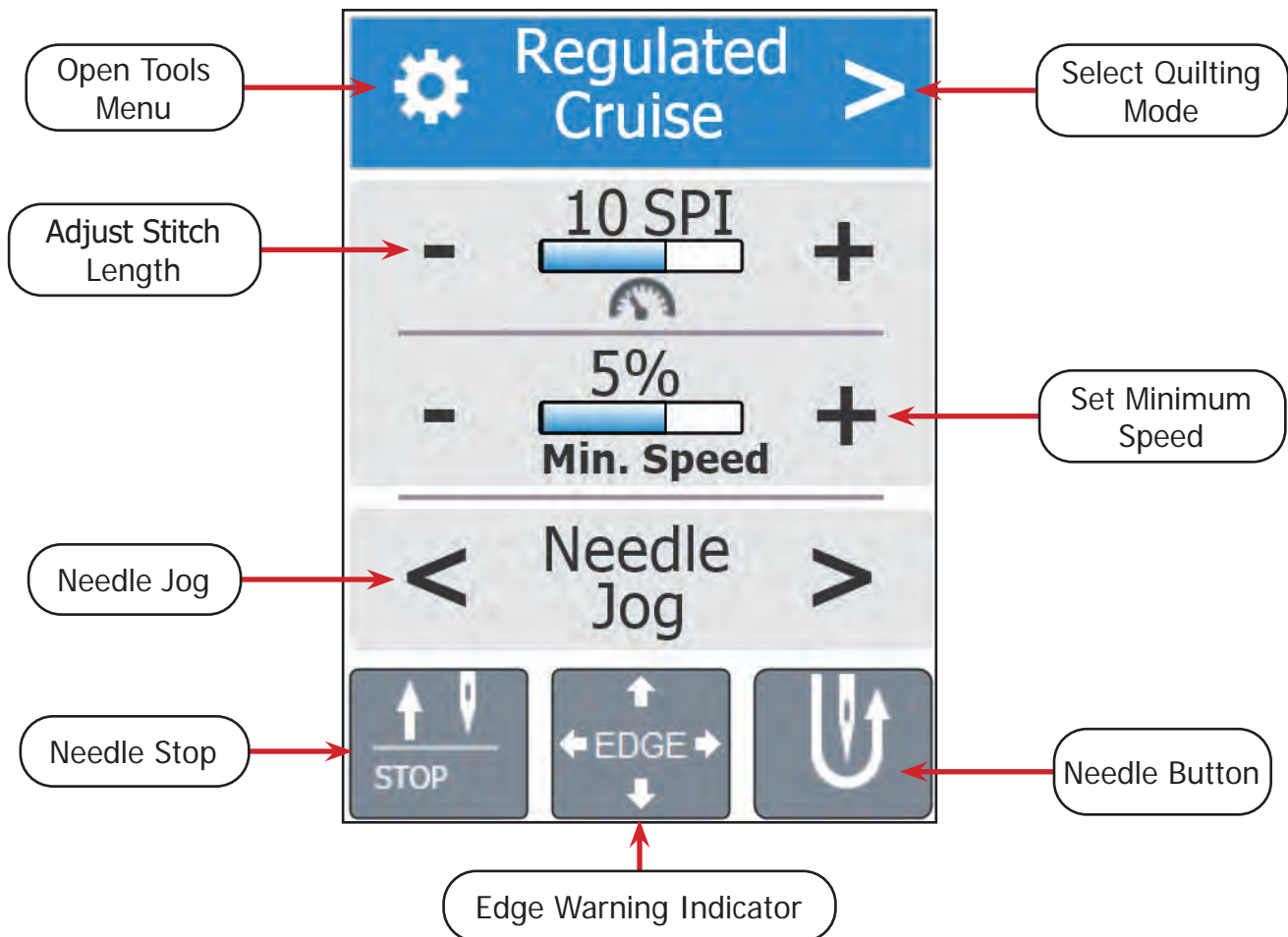



To quilt in cruise quilting mode, take the following steps:

- 1 Confirm that the **stitch length**, measured in stitches per inch or stitches per centimeter, is the desired length.

Note: The unit of measurement can be changed in the **Machine Settings** menu (see page 42).

Use the   symbols to adjust the stitch length. Higher SPI means shorter stitch length.

- 2 Determine the **minimum speed** at which the machine will stitch in place when stitching is active but the machine is not being moved. This can be set from 5% to 25% of the machine's top speed of 2000 stitches per minute.

Use the   symbols to adjust the minimum speed.

- 3 When stitching is inactive, press the **needle button** on the display to make single or half stitches. This can also be done with the needle button on the right handle. To switch the type of stitch between a half stitch or full stitch, go to the **Machine Settings** menu (see page 42)

Note: While stitching is active, the needle buttons on the display and the handlebar controls are disabled.

- 4 Position the quilting machine over the quilt. If needed, use the **needle jog** buttons to move the needle closer or farther from the fabric in small increments to help place your first stitch.



Press to move the needle up or down in small increments.

- 5 Moving the machine too quickly while quilting can reduce the quality of the stitch regulation. If the machine is moved too quickly, the overspeed alarm will sound and a red LED light will shine on the needle area. Slow the machine's movement to turn off the alarm and light. Both the alarm and light can be deactivated in the **Machine Settings** menu.

- 6 When activated, the arrows on the **edge warning indicator** on the bottom of the quilting mode screen will turn green.



For instructions on how to use the edge warning alert, see page 54.

- 7 You may find that you need to take measurements while you quilt. Press the **tools menu** button and select **measure** to open the measure tool. For instructions on how to use the measure tool, see page 60.

- 8 To deactivate stitching, press the start/stop quilting button on the handlebars. The needle will move into the needle stop position indicated by the **needle stop** button on the bottom of the quilting mode screen. Press the needle stop button to set the needle to stop in either the up or down position.

Using Manual Quilting Mode

In this quilting mode, the machine produces stitches at a certain speed. It's up to the quilter to move the machine the distance needed to get the desired stitch length. This mode is useful for small, continuous patterns.

To switch to manual quilting mode, press the **select quilting mode** button to cycle through the four quilting modes until you reach **Manual**.

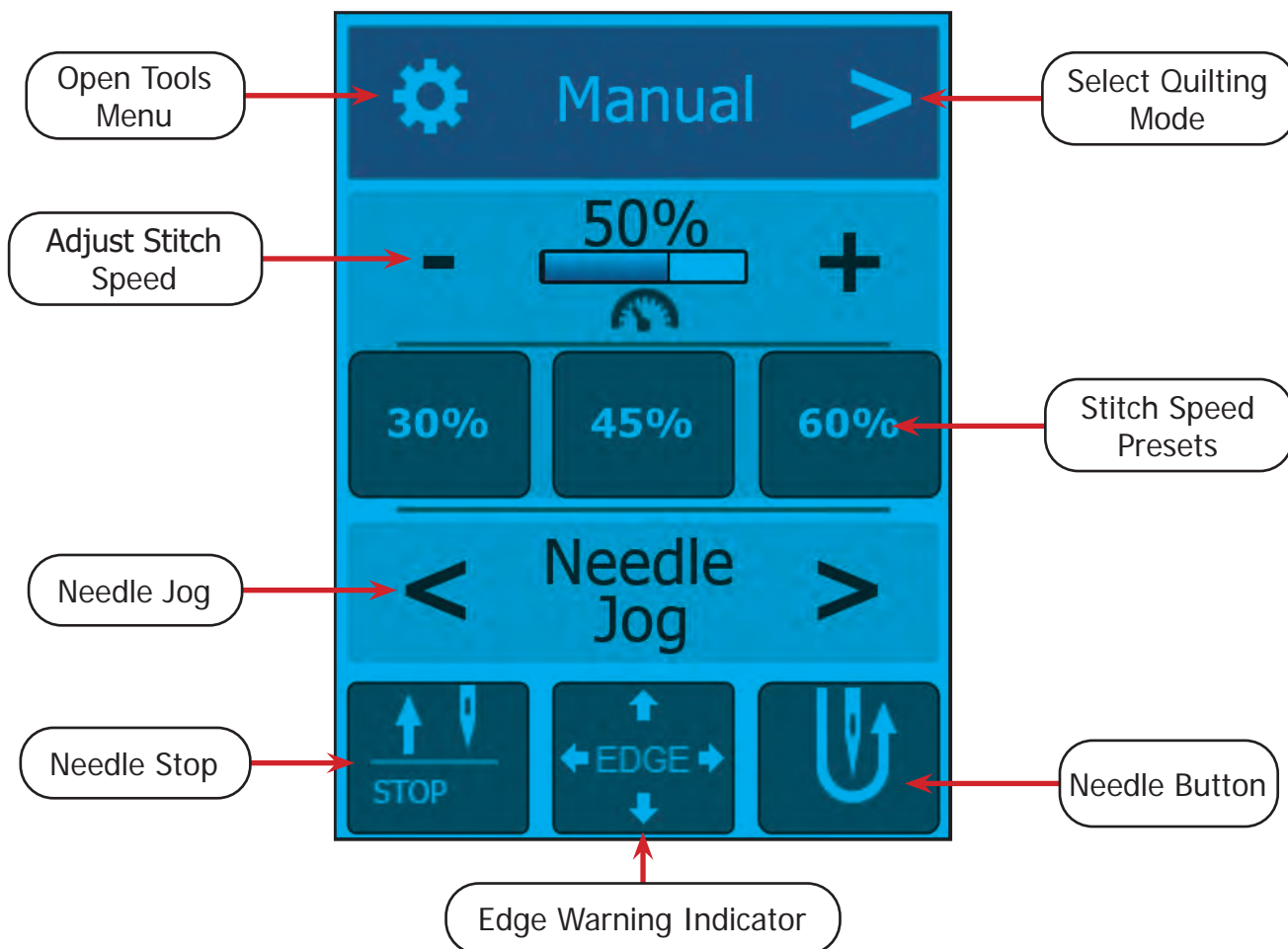

To quilt in manual quilting mode, take the following steps:

- 1 Confirm that the **stitch speed** is set to the desired speed. The speed is measured as a percentage of the machine's maximum speed of 2000 stitches per minute.

Use the **-** **+** symbols to adjust the machine speed.

- 2 When stitching is inactive, press the **needle button** on the display to make single or half stitches. This can also be done with the needle button on the right handle. To switch the type of stitch between a half stitch or full stitch, go to the **Machine Settings** menu (see page 42).

Note: While stitching is active, the needle buttons on the display and the handlebar controls are disabled.

- 3 Position the quilting machine over the quilt. If needed, use the **needle jog** buttons to move the needle closer or farther from the fabric in small increments to help place your first stitch.



Press to move the needle up or down in small increments.

- 4 When activated, the arrows on the **edge warning indicator** on the bottom of the quilting mode screen will turn green.



For instructions on how to use the edge warning alert, see page 54.

- 5 Because manual mode is not a regulated quilting mode, the overspeed alarm and warning light are automatically deactivated
- 6 You may find that you need to take measurements while you quilt. Press the **tools menu** button and select **measure** to open the measure tool. For instructions on how to use the measure tool, see page 60.
- 7 To deactivate stitching, press the start/stop quilting button on the handlebars. The needle will move into the needle stop position indicated by the **needle stop** button on the bottom of the quilting mode screen. Press the needle stop button to set the needle to stop in either the up or down position.



Using Baste Quilting Mode

Use basting mode to create loose, temporary stitches to hold layers of fabric together while quilting.

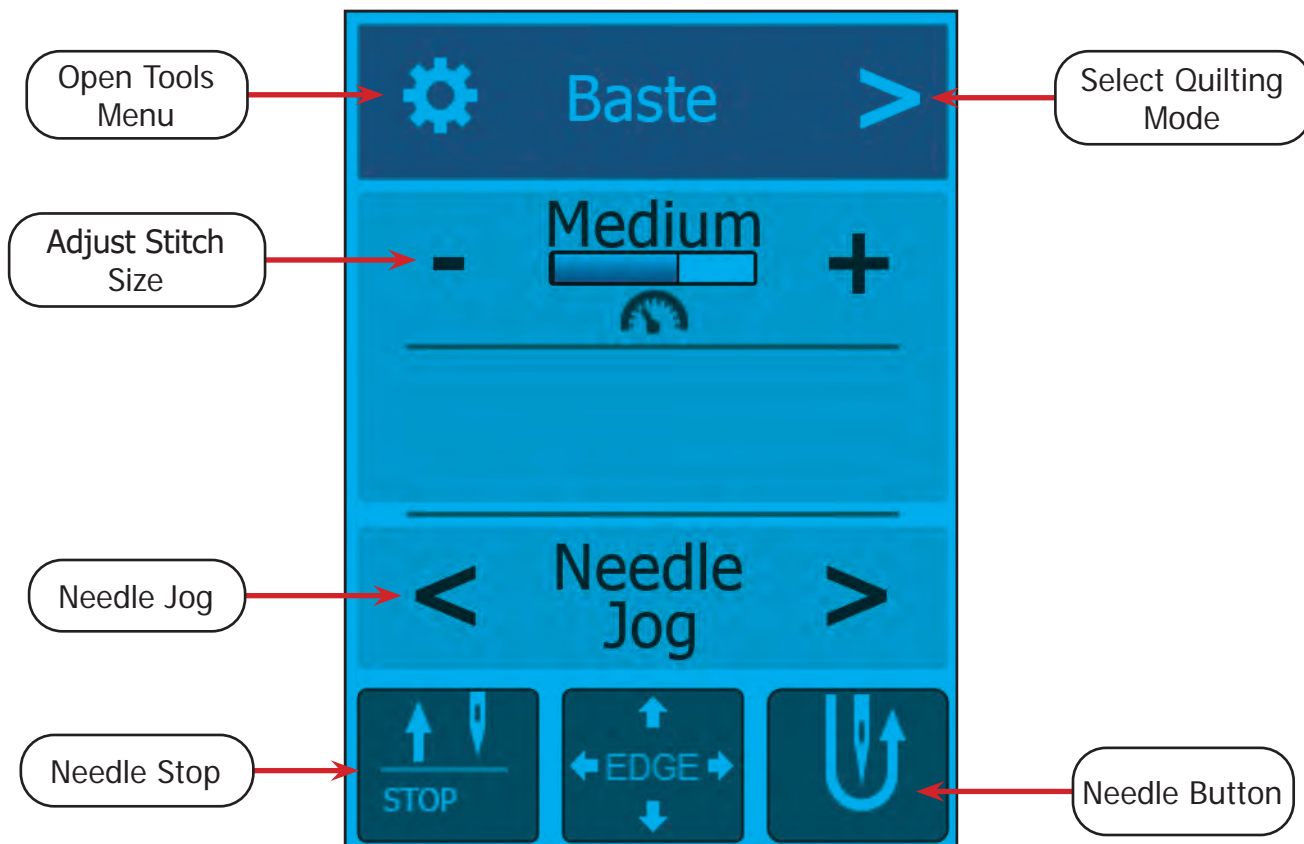
To switch to baste quilting mode, press the **select quilting mode** button to cycle through the four quilting modes until you reach **Baste**.



To quilt in baste quilting mode, take the following steps:

- 1 Confirm that the **stitch size**, (small, medium, or large) is the desired length.
Use the   symbols to adjust the stitch size.
- 2 When stitching is inactive, press the **needle button** on the display to make single or half stitches. This can also be done with the needle button on the right handle. To switch the type of stitch between a half stitch or full stitch, go to the **Machine Settings** menu (see page 42).

Note: While stitching is active, the **needle buttons** on the display and the handlebar controls are disabled.

- 3 Position the quilting machine over the quilt. If needed, use the **needle jog** buttons to move the needle closer or farther from the fabric in small increments to help place your first stitch.



Press to move the needle up or down in small increments.

- 4 Moving the machine too quickly while quilting can reduce the quality of the stitch regulation. If the machine is moved too quickly, the overspeed alarm will sound and a red LED light will shine on the needle area. Slow the machine's movement to turn off the alarm and light. Both the alarm and light can be deactivated in the **Machine Settings** menu.
- 5 Edge Warning is not active in Baste Mode.
- 6 You may find that you need to take measurements while you quilt. Press the **tools menu** button and select **measure** to open the measure tool. For instructions on how to use the measure tool, see page 60.
- 7 To deactivate stitching, press the start/stop quilting button on the handlebars. The needle will move into the needle stop position indicated by the **needle stop** button on the bottom of the quilting mode screen. Press the needle stop button to set the needle to stop in either the up or down position.

Screen Settings

The Screen Settings menu allows you to calibrate the display's touchscreen as well as select a color theme for the display.

- 1 To access the screen settings menu, click on the tools icon in the top left corner of the screen and select **Screen Settings**.

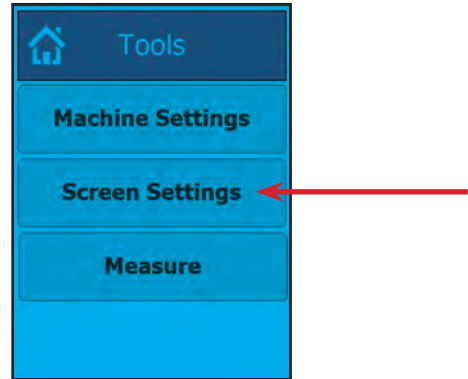
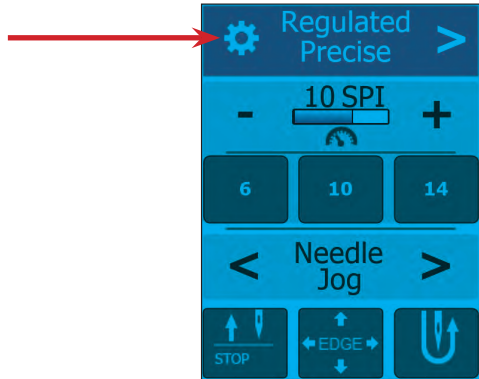

- 2 The Screen Settings menu opens. Press the **Color Theme** button to cycle through the three color modes. Press the **Screen Calibration** button to open the calibration screen.

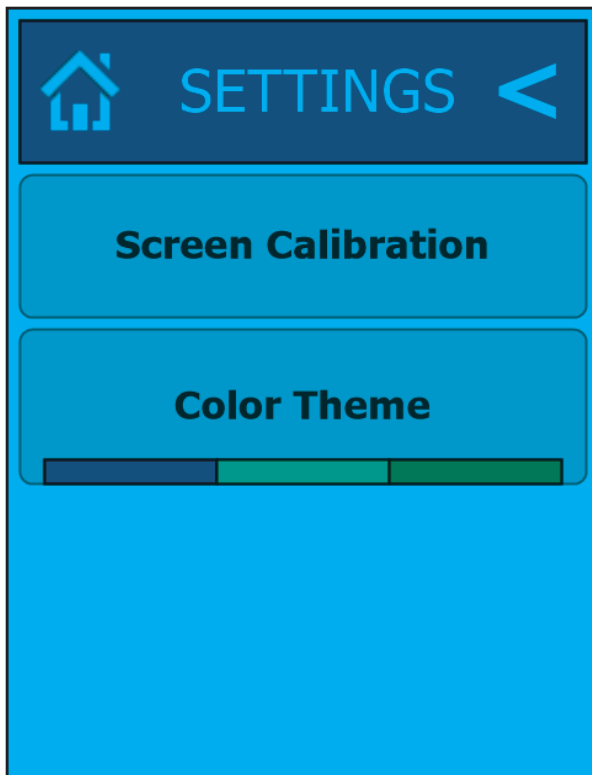

- 3 To calibrate the screen, follow the prompts to click in the top right corner and then the bottom left corner.

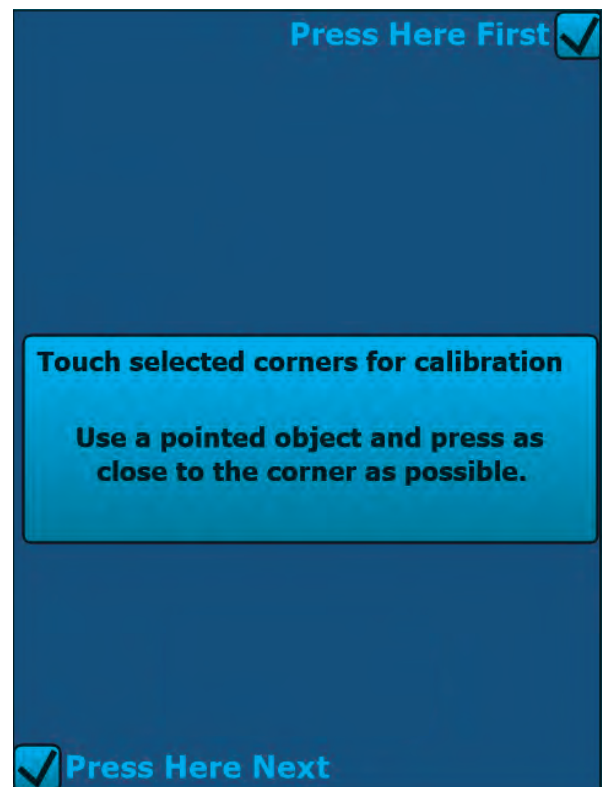

- 4 Click **Finished** when done to return to the screen settings menu.



Using the Edge Warning

The edge warning alert system helps you stay within a “safe area” of your quilt by notifying you when you approach the edge of a set boundary. This will help prevent the machine from hitting the rails of the frame, but you can also set boundaries around a particular block or section of the quilt.

Take the following steps to use the edge warning tool.

- 1 To access the edge warning tool, press the **edge warning button** on the bottom of the quilting mode screen.

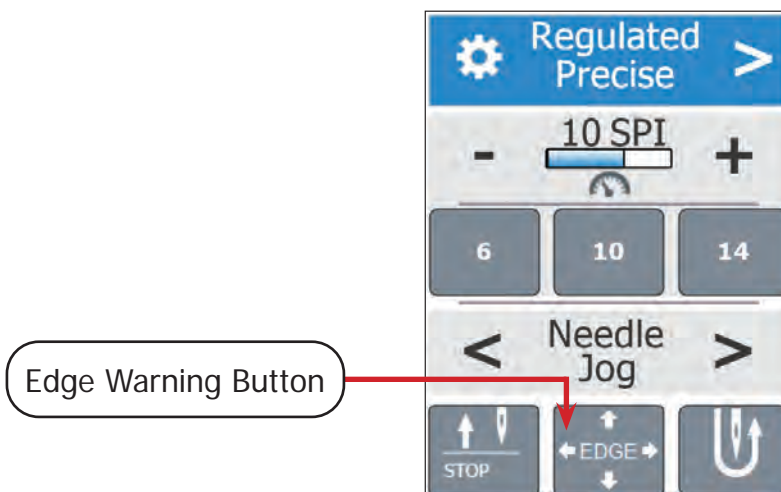

Note: Edge Warning is automatically deactivated in Baste Mode.

- 2 Move your machine so that the needle area is positioned at the location you want to be the top left corner of your safe area. Then press the **Upper Left** button.

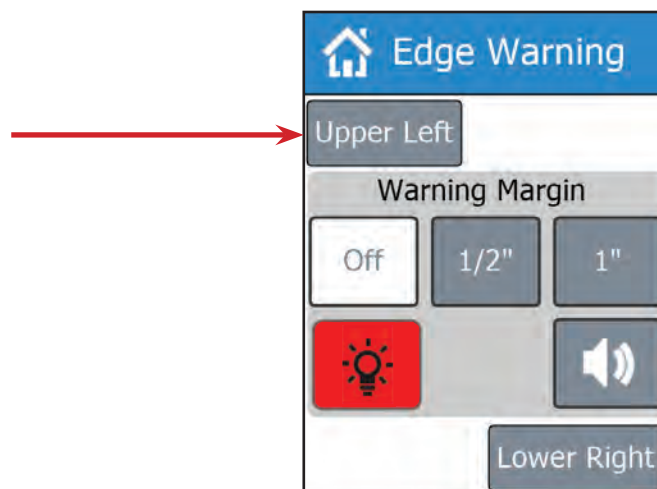

Part Four | Quilting

Using the Edge Warning (Continued)

- 3 Now move your machine to the location you want to be the bottom right corner of your safe area and press the **Lower Right** button.



- 4 Choose whether you want the edge warning to notify you when the machine is within one inch or half an inch of the set boundaries. The edge warning is now set.



- 5 The arrows on the edge warning button in the quilting mode screen will turn green when edge warning is activated.



- 6 If you approach any of the boundaries while quilting, an alarm will sound and a red LED light will shine on the needle area



- 7 To turn off the alarm and red light, return to the established "safe area." The light and the alarm can each be deactivated in the edge warning screen.



- 8 If you do not want the edge warning to be activated, press the "Off" button on the edge warning screen.

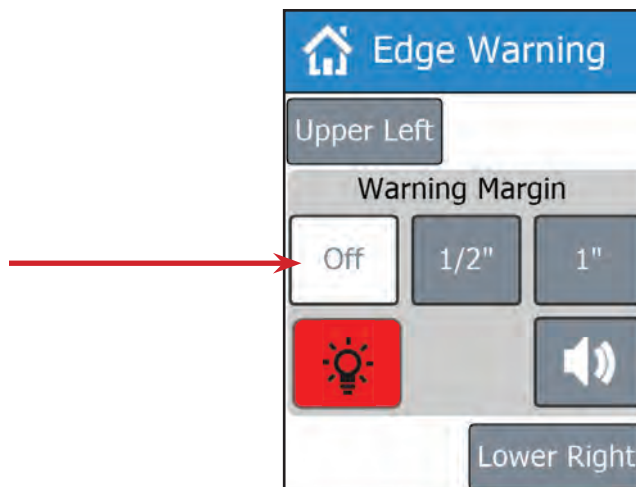

Adjusting Thread Tension

Proper thread tension prevents unwanted puckering, poorly-formed stitches, and malfunctions that can damage the fabric. Test your thread tension on extra materials before sewing on a project.

Tip: Bottom thread tension is addressed in “Task 10 - Loading the Bobbin Case” (see page 32). This should be done before adjusting top tension.

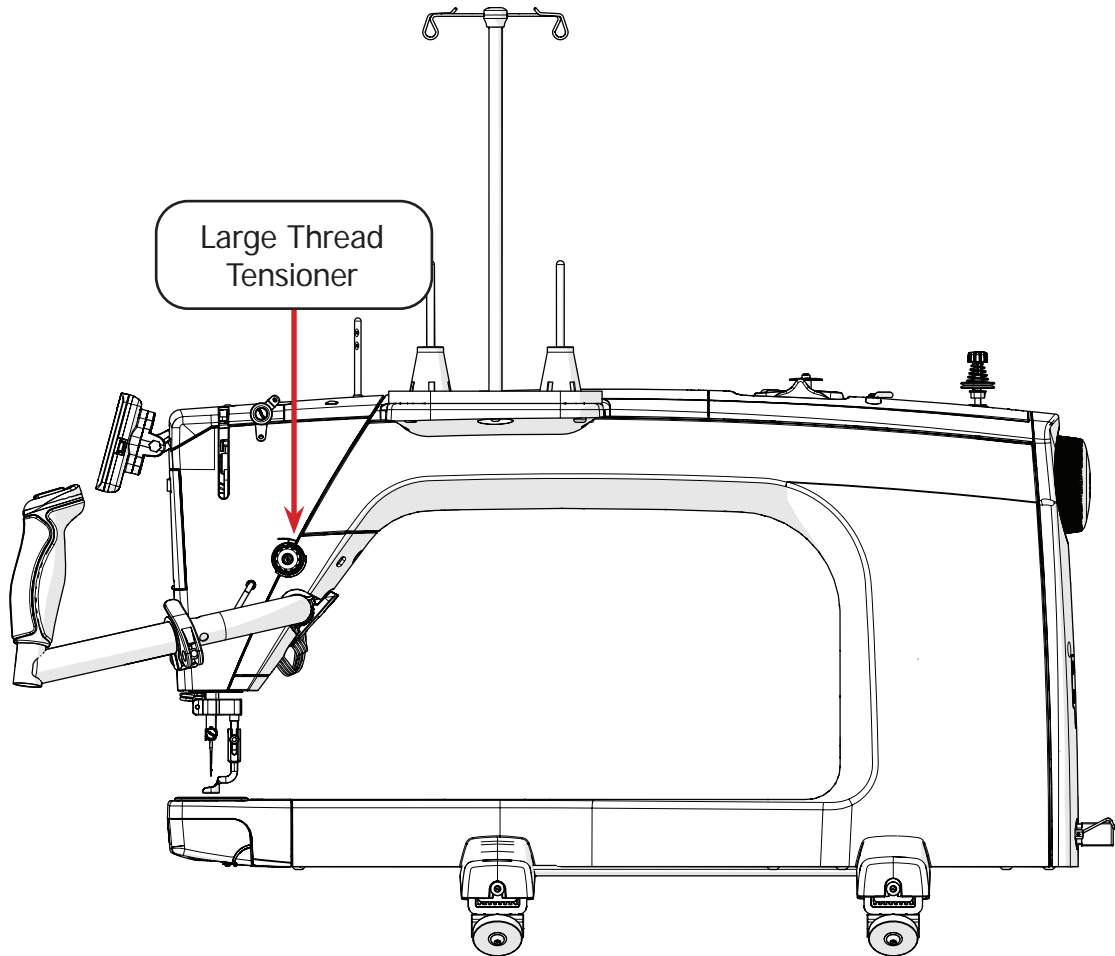

- 1 Loosen the **tension knob** on the **large thread tensioner** to set the tension to “1.” The bottom of the tension knob will line up with the number that the tension is set to.

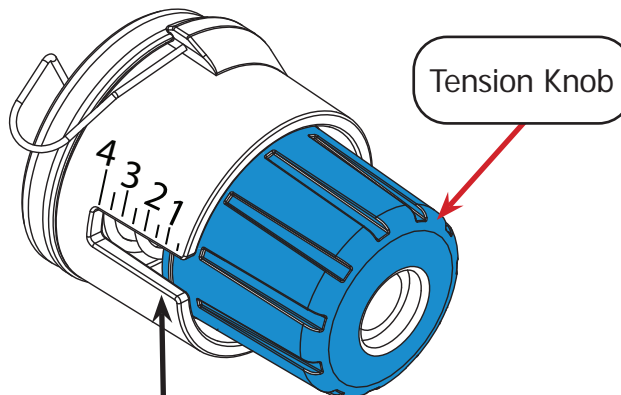

Note: Setting “1” is the lowest tension for your machine, and is an ideal starting place to find the correct top tension.

- 2 Slowly increase the tension while stitching into scrap material. When the thread tension is balanced, the top and bottom thread will knot in the middle of the fabric layers.

**Too Much Top
Tension**

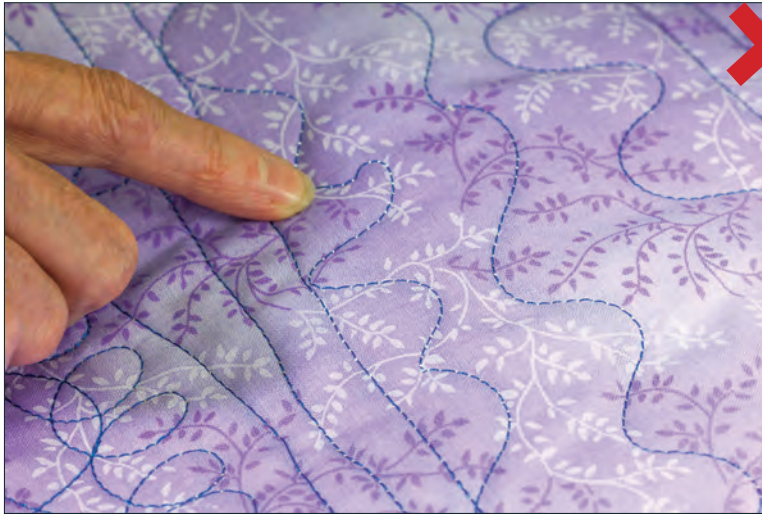

Bottom thread is
pulled to the top
of the fabric.

**Balanced
Tension**

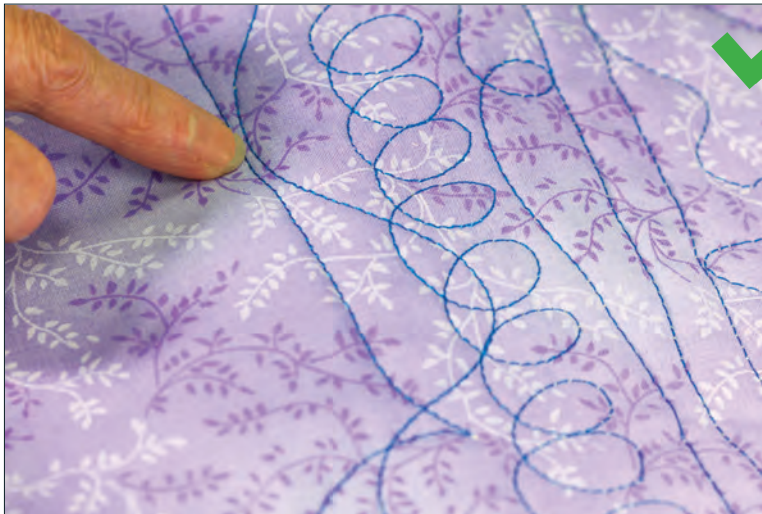

**Too Little Top
Tension**



Top thread is
pulled to the
bottom of the
fabric.

Adjusting Thread Tension (Continued)

- If the **bobbin (bottom) thread** is pulled through the top layer of fabric, there is too much top tension. Loosen the tension by turning the large thread tensioner knob toward the setting "1." Stop turning the knob when desired tension is achieved.

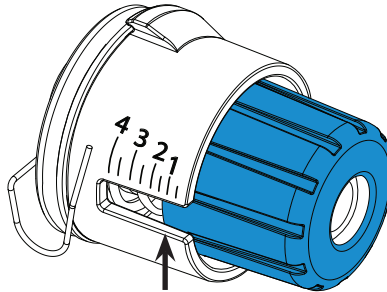

- If the **top thread** is pulled down through the bottom layer of fabric, there is too little top tension. Increase the tension on the top by slowly turning the large thread tensioner knob toward setting "4." Stop turning the knob when desired tension is achieved.

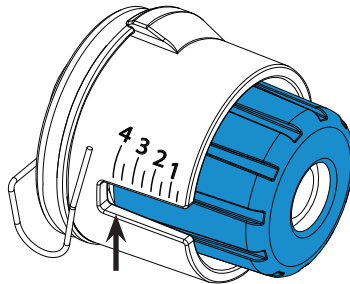

Taking Measurements

Your machine can be used to take measurements across the surface of your quilt.

- 1 To access the measure tool, click on the tools icon in the top left corner of the screen and select **Measure**.

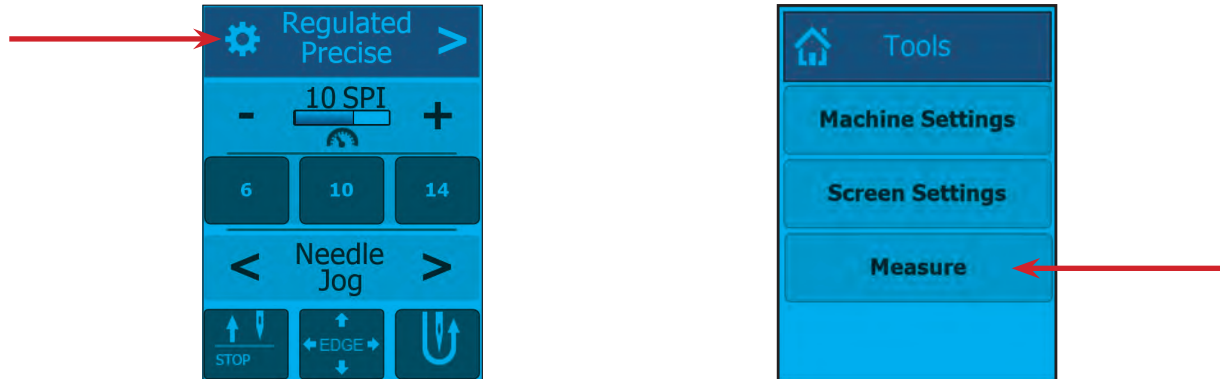

- 2 Move your machine so that the needle is at the location where you want to start your measurement and press the **Start** button

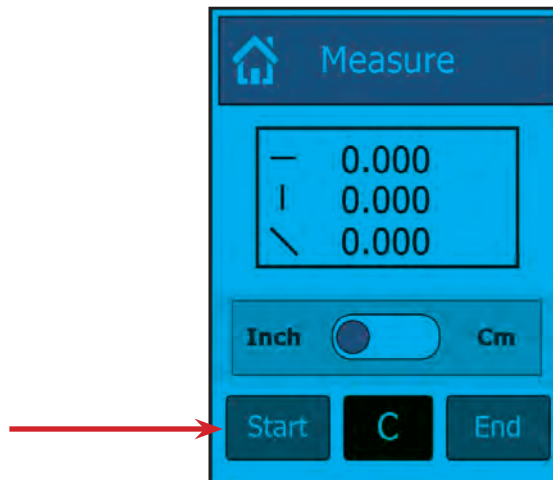

Note: You can select either inches or centimeters for your unit of measurement.

- 3 Move your machine so that the needle is at the end of your measurement and press the **End** button.

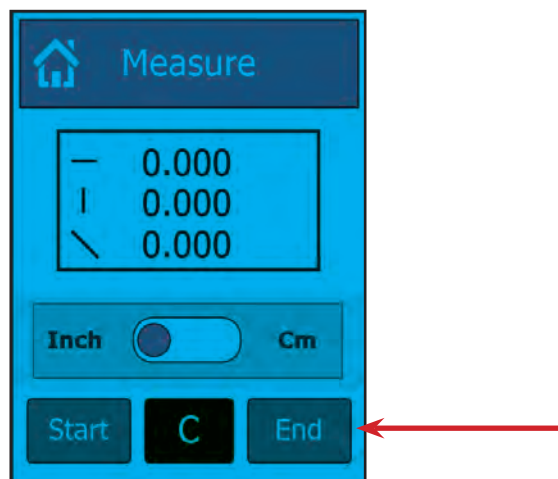

Part Four | Quilting

Taking Measurements (Continued)

- 4 The screen will display the horizontal, vertical and diagonal distances from your start point to your end point.

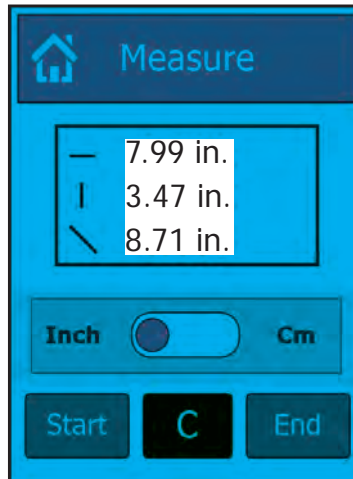

- 5 Press the **End** button again if you want to create a measurement with the same start point but a new end point.

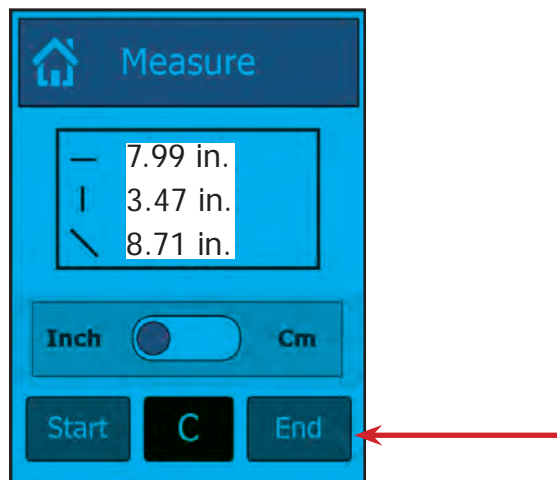

- 6 Press the **clear** button once you no longer need to save the measurement or if you are ready to make a measurement with a new start point.

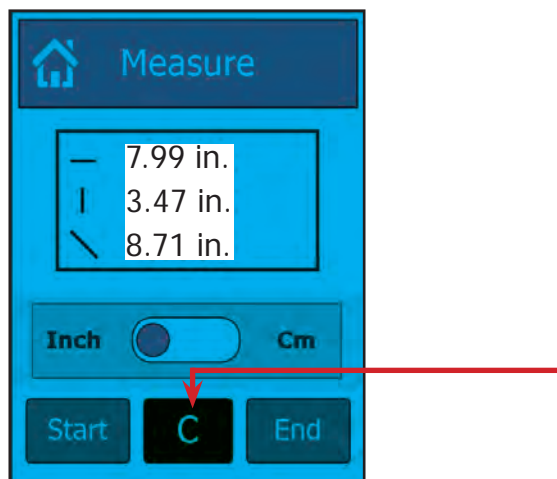

System Info

The System Info screen shows the firmware versions of your machine and display. It also shows the stitch count and run for both the current project and the life of the machine.

- 1 To access the System Info screen, press the **info button** on the Machine Settings screen

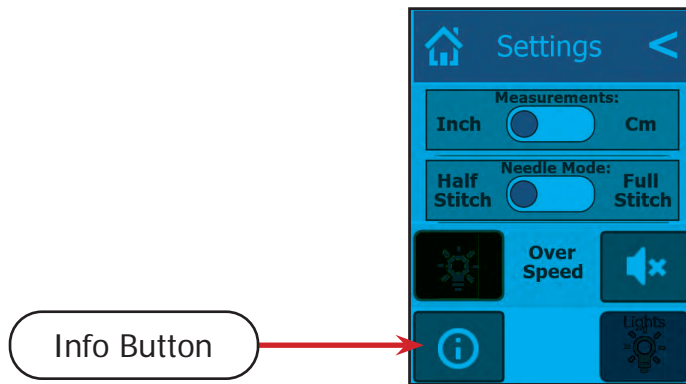

- 2 This screen will show the version details for your machine and display. It also shows the run time and stitch data for both the current project and lifetime of the machine.

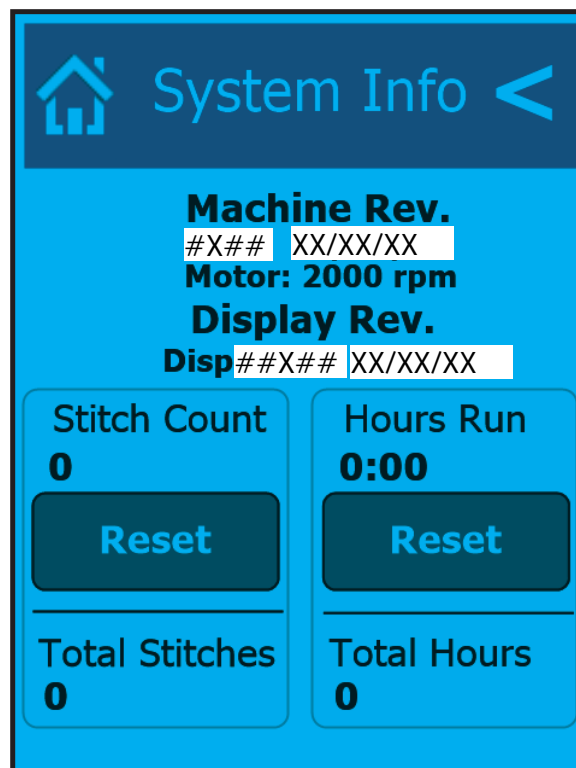

Tip: It's recommended to oil your machine after 20 hours of use. The "Hours Run" counter can help keep track of when your machine is due to be oiled. After cleaning and oiling your machine, press the **Reset** buttons under "Hours Run" and "Stitch Count" to start the counters back at zero.

The counters under "Total Stitches" and "Total Hours" cannot be reset.

Getting Started

Parts & Tools Needed:

Scissors
(not included)

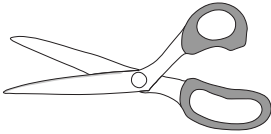

Washable Fabric
Marker/chalk (not
included)

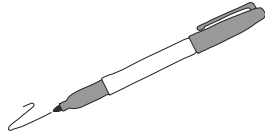

Instructions

With the machine fully assembled, you are ready to begin quilting. Practice on spare fabric to become familiar with the machine's settings and movements so you can start your projects with confidence. It is normal to make mistakes, so don't get discouraged if your stitches don't look perfect right away. Follow the steps in this section to get started and you'll be quilting in no time!

- 1 **Relax!** Take a deep breath and don't be afraid to take it slow.

Make sure that the following items have been completed:

- Your machine is threaded and tensioned.
- Your practice fabric is attached.
- You have established any machine settings you want to use.

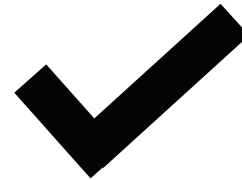

- 2 Before you begin stitching, pull up your bobbin thread to prevent the thread tail from dangling underneath the fabric as you quilt and getting sewn in place.

- a First, position the needle directly above where you want to begin your pattern.
- b Pull on the **top thread** so that it is tight and jog the needle up and down using the single needle button on the display.

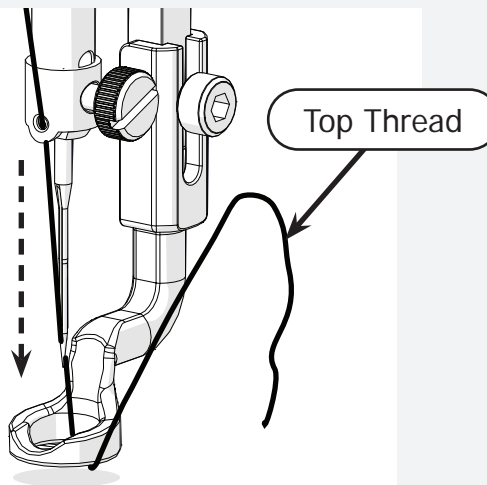

- c While still tightly holding the top thread, move the machine several inches to the side. Your top thread should pull a loop of **bobbin thread** through the **start point** to the top of the fabric.

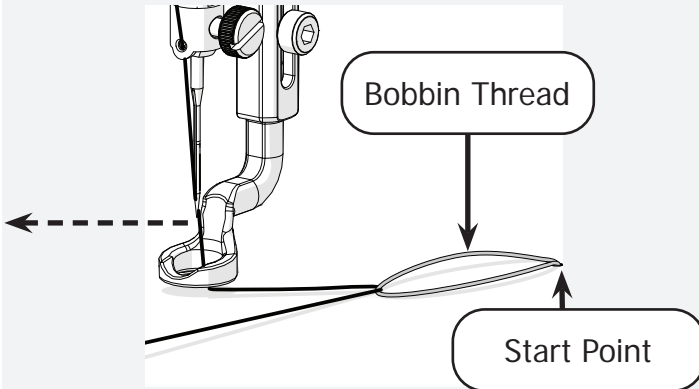

- d Pull on the loop of **bobbin thread** until the loose end of the thread comes up from underneath the fabric.

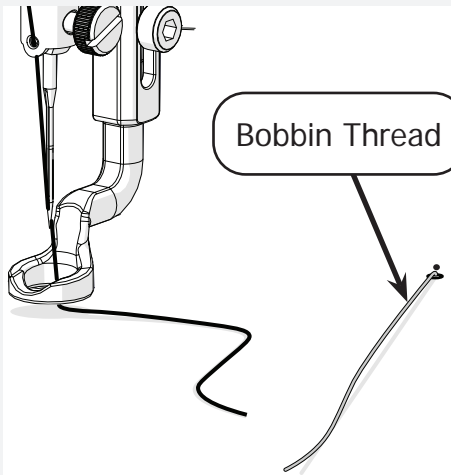

- e Pull on the bobbin thread while moving the machine back to the start point. This makes sure that there is no loose thread underneath the fabric.

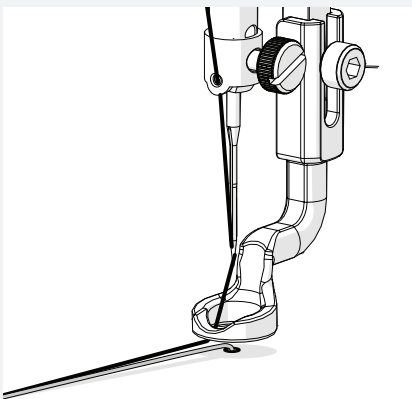

- 3 Begin stitching. Be sure to start your pattern as close as possible to the start point where you pulled out the bobbin thread.

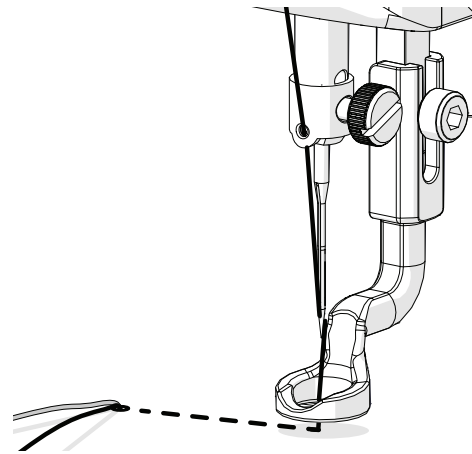

- 4 With fabric chalk or a marker, draw a simple pattern or write your name on the fabric and then stitch over it to practice.

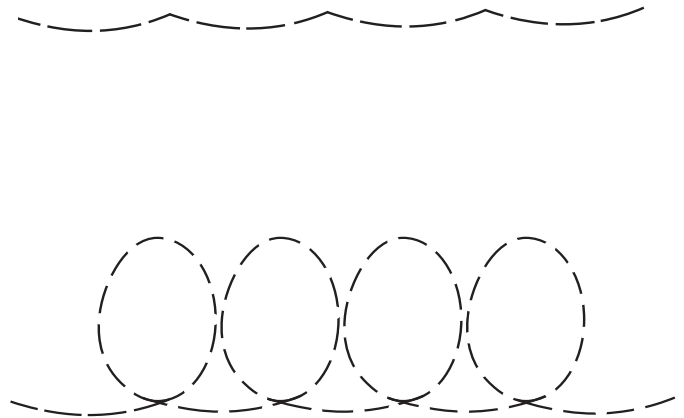

Grace

Part Four | Quilting

Getting Started (Continued)

- 5 Complete the pattern by making a tie-off stitch. Use the single needle button to make a few small stitches very close together.



- 6 To pull up the bobbin thread after making a tie-off, take the following steps:

- a Move the machine away from the tie-off stitch.

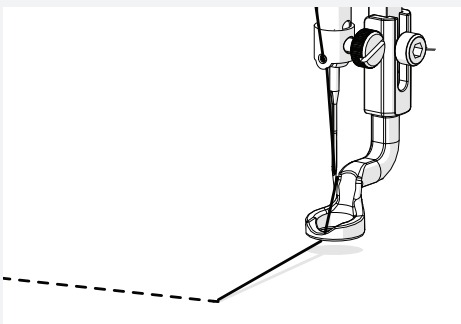

- b Hold the thread to make a loop and return the machine to the tie-off stitch.

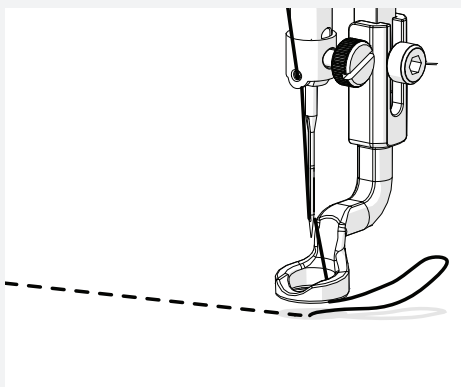

- c Make a single stitch over the tie-off.

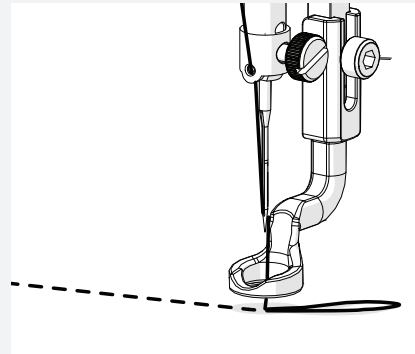

- d Hold the loop and move the machine away from the tie-off again.

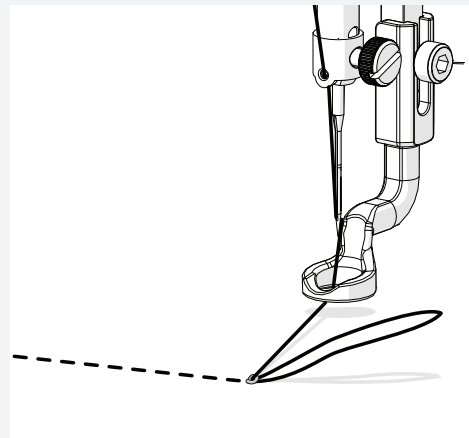

- e Keep moving away from the tie-off until a loop of bobbin thread is pulled up above the fabric. Cut all threads close to the tie-off.

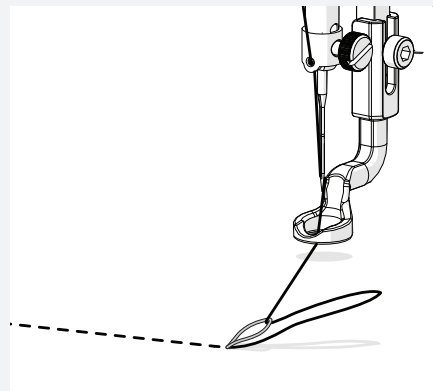

- 7 You may now cut the thread tails from the beginning of the pattern.

Practice! Keep trying different stitches until you feel comfortable with how your machine feels and moves. You can always attach a new piece of practice fabric if you need to.

Congratulations! Now that you have practiced and gotten used to the basic settings and movements of your machine, you are ready to begin your quilting journey.

If you have any accessories that you have not installed yet, you may do so now.

Good luck, and thank you again for choosing The Grace Company to help with your quilting needs.

Maintaining the Machine

Keep your machine performing at its peak by practicing good machine maintenance habits.

This section of the manual covers oiling the machine, changing the needle, adjusting the bobbin cam and hopping foot, and reinstalling the needle plate.

Preparing the Oil Bottle	page 68
Oiling and Cleaning	page 69
Changing the Needle	page 73
Adjusting the Hopping Foot	page 96
Reinstalling the Needle Plate	page 80

Preparing the Oil Bottle

Parts & Tools Needed:

Oil Bottle

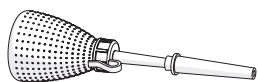

Box 7

Scissors

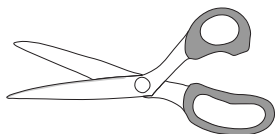

(Not included)

Instructions

Take the following steps to prepare the oil bottle for use in oiling the machine.

- 1 Snip off about 1/4th of an inch from the tip of the plastic lid with a pair of scissors.

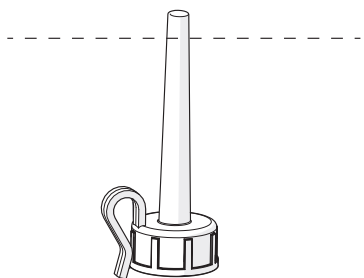

- 2 Place the applicator needle onto the top of the cap.

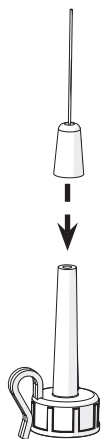

- 3 Peel the safety foil off the opening of the oil bottle.

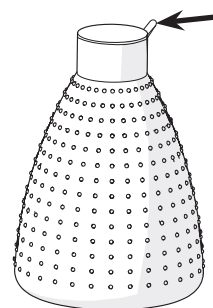

- 4 Carefully screw the lid onto the oil bottle.

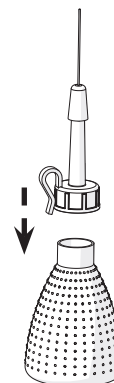

- 5 Hold bottle upside down and squeeze gently to apply oil. When not in use, cover the applicator needle with the safety cap.

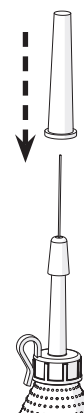
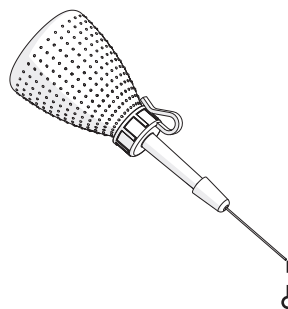

Oiling and Cleaning

Parts & Tools Needed:

Lint Brush

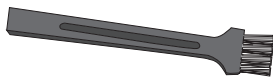

Box 1

Oil Bottle

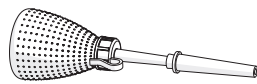

Box 7

- Compressed Air Can (optional; not included)

Instructions

Oil and Clean:	
Machine	<ul style="list-style-type: none"> • At the start of a new project • After 20 hours of use • After sitting without use for more than 30 days
Hook Assembly	<ul style="list-style-type: none"> • Every other bobbin change

Tip: The Hours Run counter on the System Information page can be used to track hours of quilting time (see page 62).

Take the following steps to clean and oil the machine:

- 1 Power off the machine.
- 2 Set the **large thread tensioner** to “1” to expose the tensioner discs. Use the lint brush or a can of compressed air to clear away lint and thread remnants from between the discs.

Note: Lint build-up between the tensioner discs can prevent proper thread tensioning.

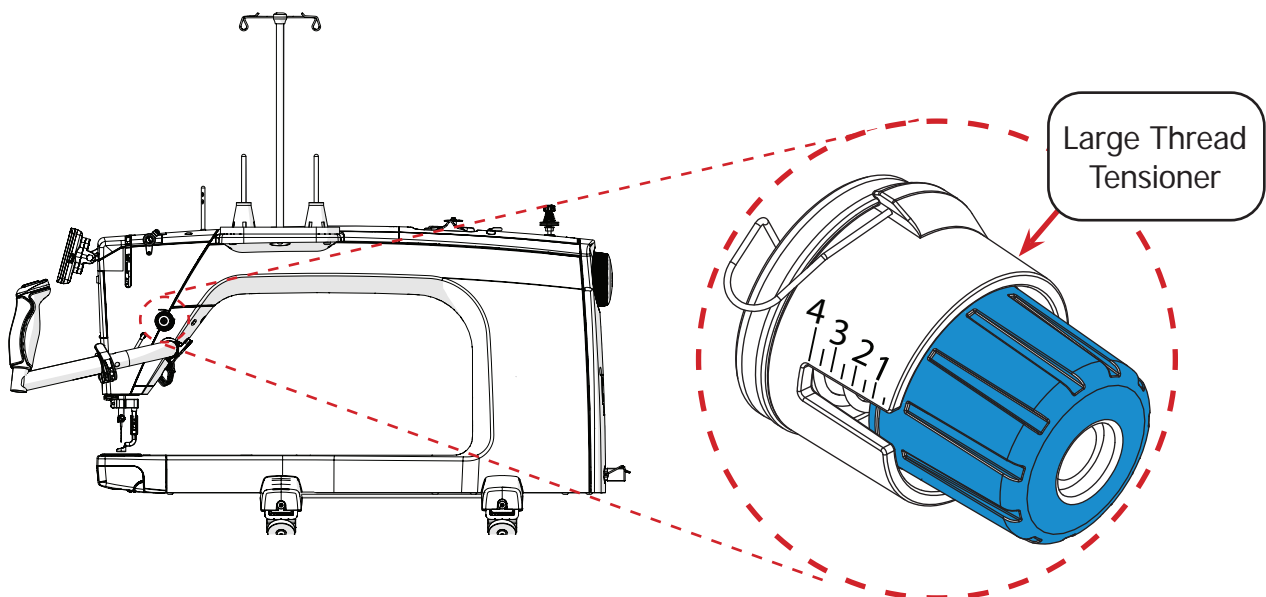

- 3 Clear debris from the spring and discs of the **small thread tensioner**.

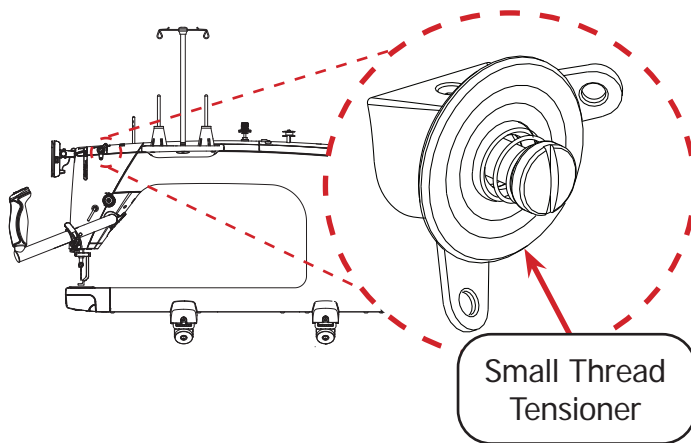

- 4 Press in on the hook assembly cover and push down to open it.

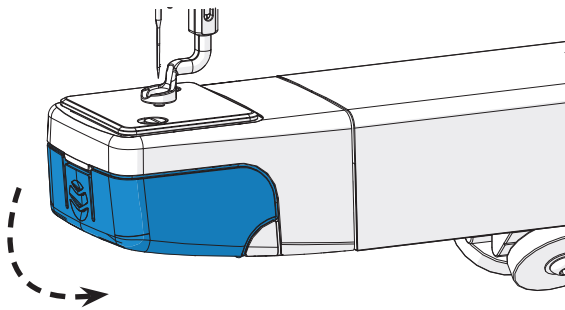

- 5 Pull the **release lever** (shown in blue) on the bobbin case to remove it from the hook assembly. If the case won't release, raise the needle with the hand wheel at the rear of the machine.

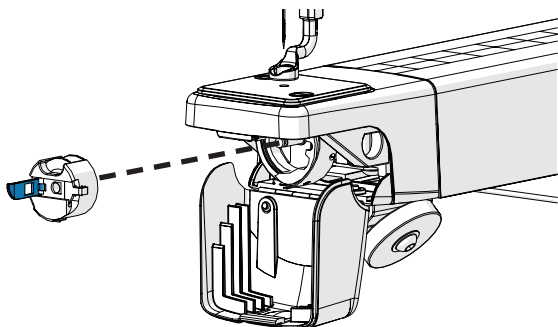

- 6 Set the bobbin aside. Clean the bobbin case with the lint brush or compressed air. Be sure to clean the area under the **bobbin tension thread arm**.

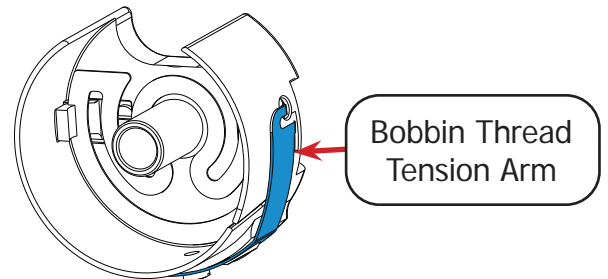

- 7 In and around the **hook assembly**, clear away any lint, cloth, and thread remnants.

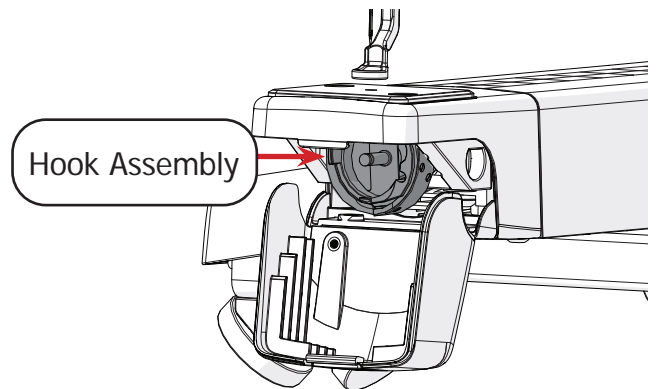

- 8 Rotate the **hand wheel** until the needle is halfway down. This will put the hook in the best position for oiling.

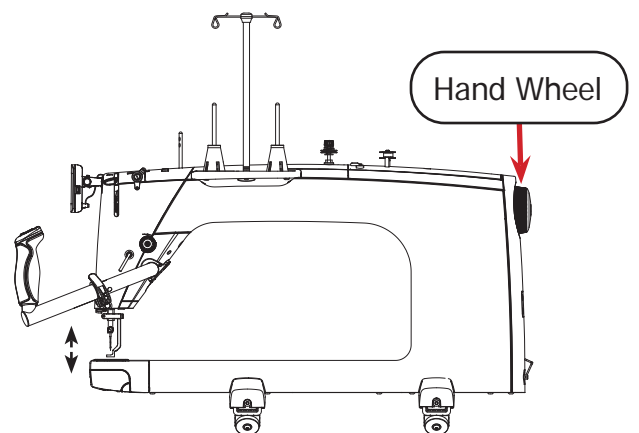

Part Four | Maintaining the Machine

Oiling and Cleaning (Continued)

- 9 Place one to two drops of oil into the hook assembly between the **inner part** (shown in gray) and **outer part** (shown in blue). Do not re-install the bobbin case yet.

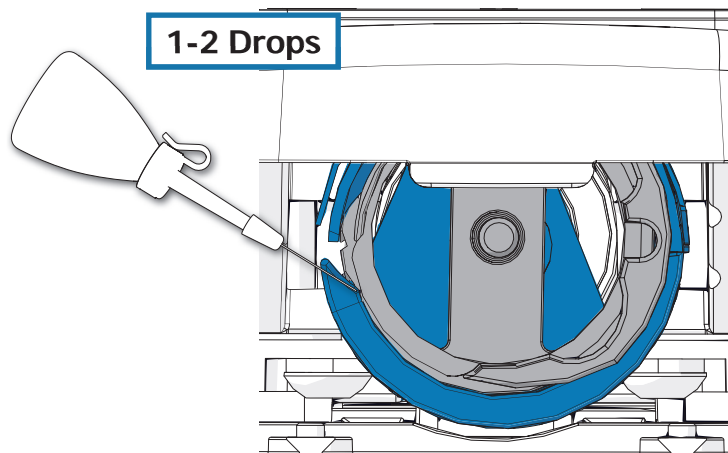

- 10 Unplug the **display cable** from the port on the machine.

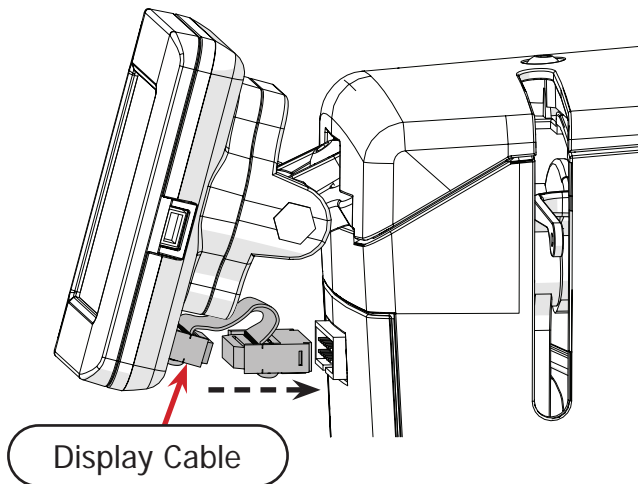

- 11 Lift the tab on the **display board cover** and remove it from the machine.

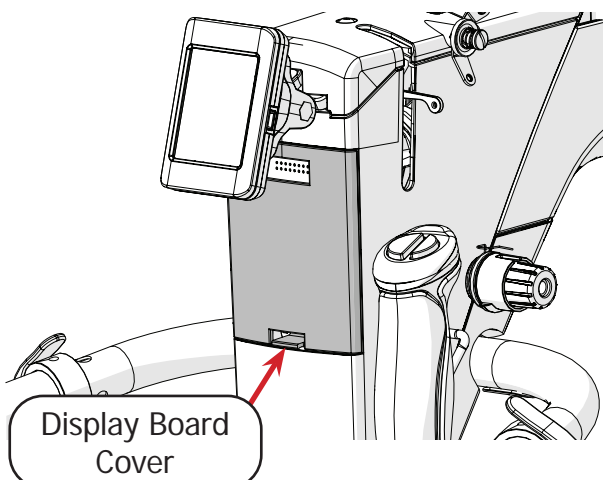

- 12 Place 1-2 drops of oil on the needle bar. Replace the display board cover and the display cable.

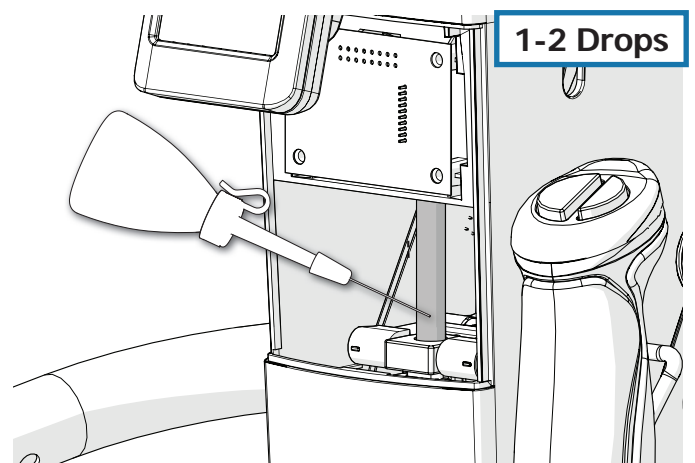

- 13 Power up the machine. Run the machine in manual or cruise stitching modes without a bobbin installed for about 10 seconds. This will distribute the oil in the hook assembly without getting oil on your bobbin thread.

- 14 Reload the bobbin case and return it to the machine (for detailed instructions on tensioning the bobbin case, see page 32). Close the hook assembly cover.

Unplug the **display cable** from the front of the machine.

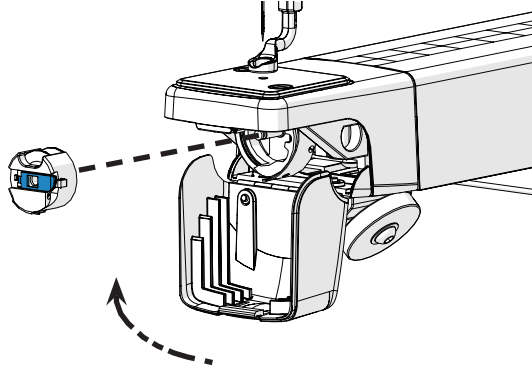

- 15 Regularly wipe down the **needle bar** to prevent the accumulation of oil that can stain your fabric.

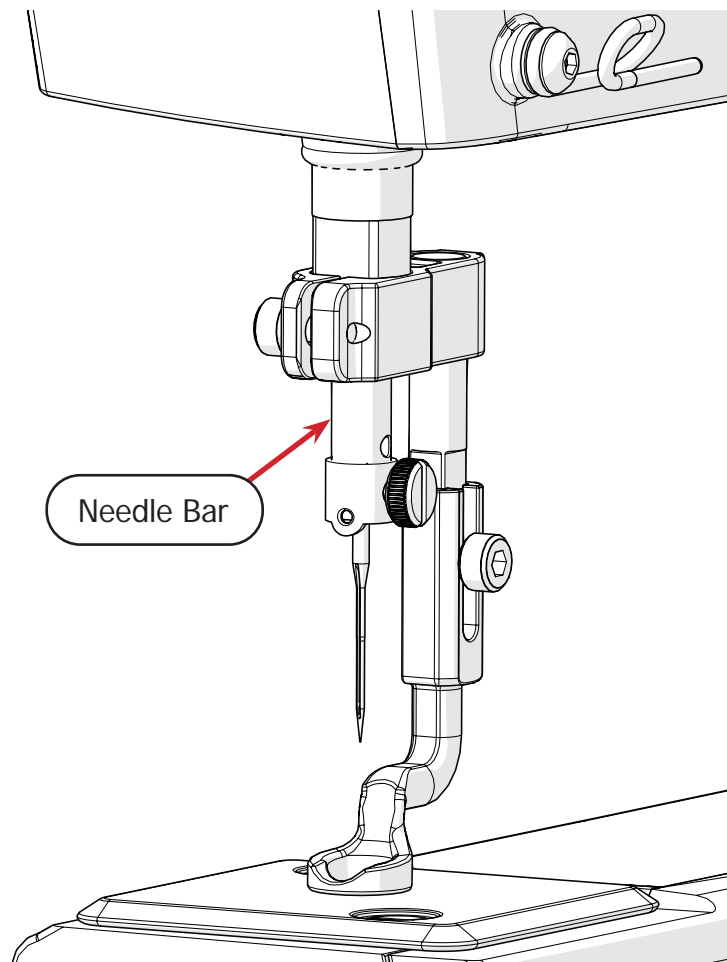

Changing the Needle

For information on selecting a needle, see "Choosing Your Needle" on page 96.

Parts & Tools Needed:

Needle



Box 1

Needle Magnet

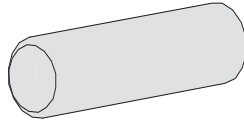

Box 1

Flat-head Screwdriver

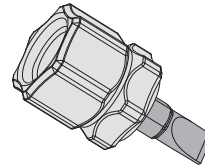

Box 1

Instructions

A broken, bent, or burred needle may break thread, damage fabric, or even damage the machine. Always check that the needle is in good condition before starting a new project, and replace the needle after eight hours of use.

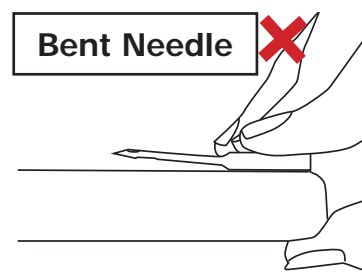
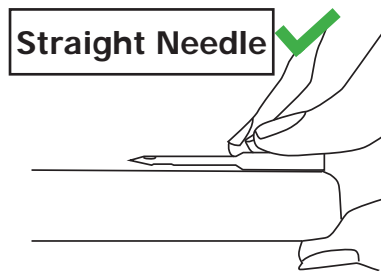

To avoid damage to the machine, please choose an approved needle style from the list below:

- DPX5 MR
- 134 MR
- 1955 MR

- 1 Power off the machine.
- 2 Raise the needle to the highest position with the **hand wheel**.

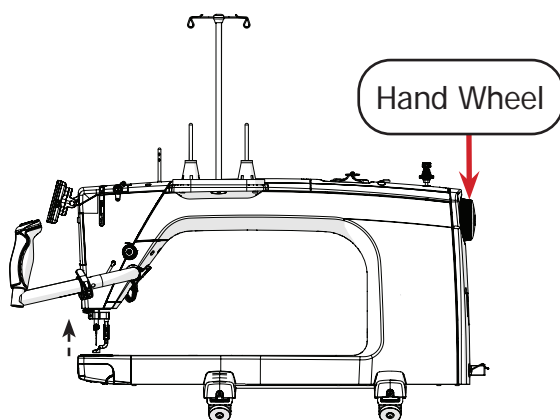

- 3 Loosen the **needle thumb screw** and pull out the needle. If needed, use a flat-head screwdriver to loosen the screw.

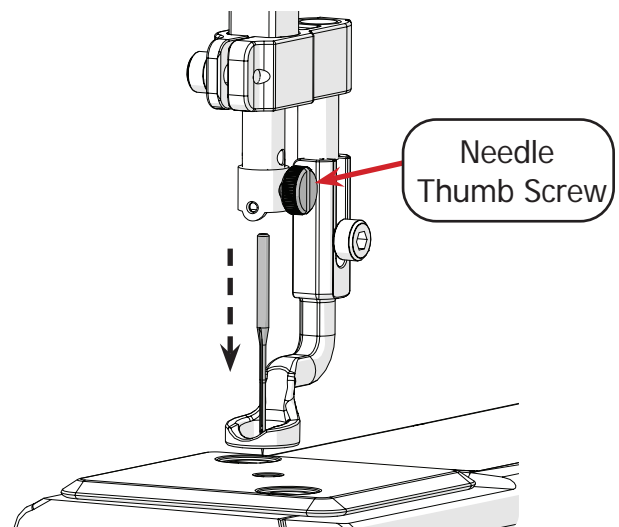

- 4 Insert the new needle all the way into the needle bar. Check the **needle bar sight hole** above the thumb screw to make sure the **needle** is inserted all the way.

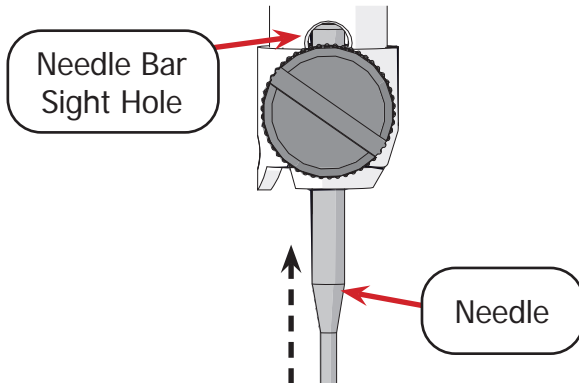

- 5 The **scarf**, a cut-out on the back of the needle, should face the throat of the machine. Place the **needle magnet** on the opposite side of the scarf.

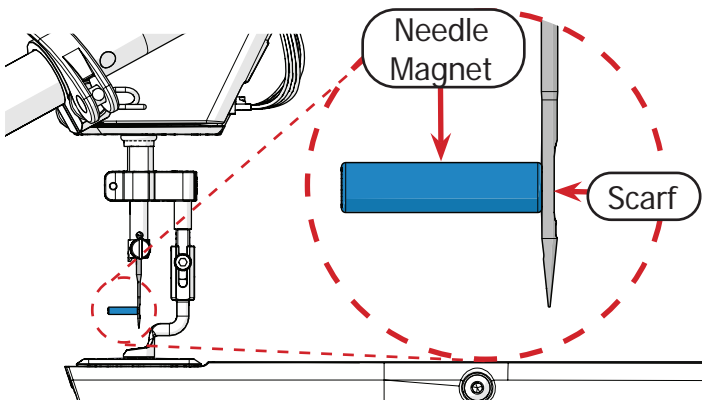

- 6 Use the needle magnet as a visual guide. Twist the needle until the **magnet** (shown in blue) points as straight out from the machine as possible. **Note:** Do not attempt to adjust the needle by moving the magnet directly.

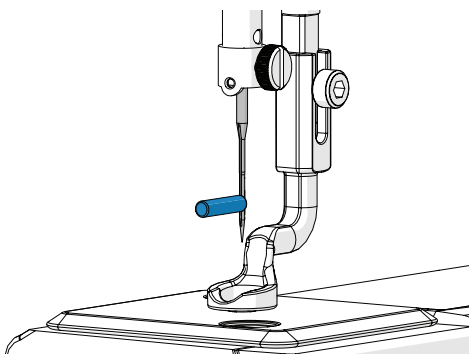

- 7 Hand-tighten the **needle thumb screw**. Do not over-tighten if using the flat-head screwdriver.

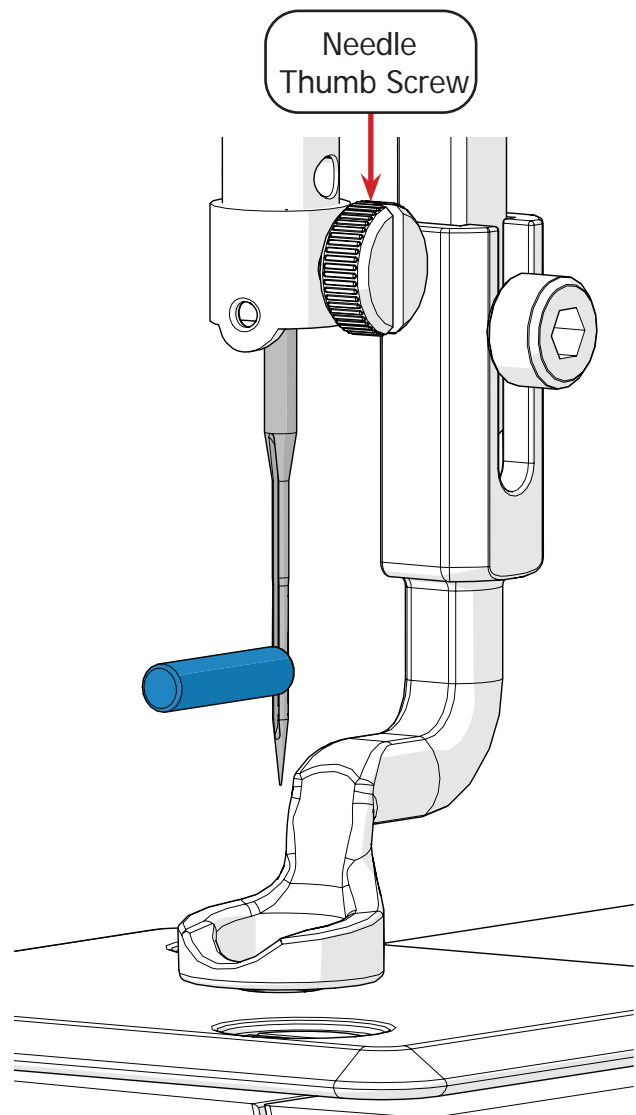

Adjusting the Hopping Foot

Parts & Tools Needed:

T-handle Allen
Wrench 3 mm

Hopping Foot
Height Tool

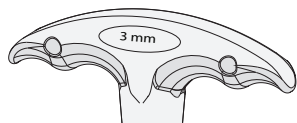

Box 1



Box 1

Height Adjustment

When quilting with thick fabric or batting layers, the hopping foot may press down on the quilt too tightly and begin to drag. Alternatively, having the hopping foot too high can result in skipped stitches. The hopping foot can be raised or lowered to correct these problems.

To adjust the hopping foot height, take the following steps:

- 1 Move the machine so it is not over fabric. Then use the **hand wheel** to drop the needle bar to the lowest position.

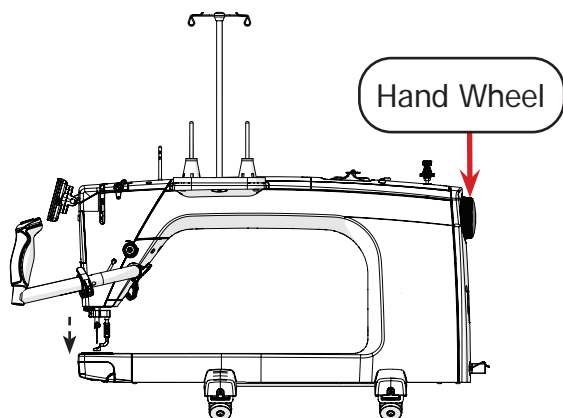

- 2 Use the 3 mm Allen wrench to loosen, but not remove, the **hopping foot screw**.

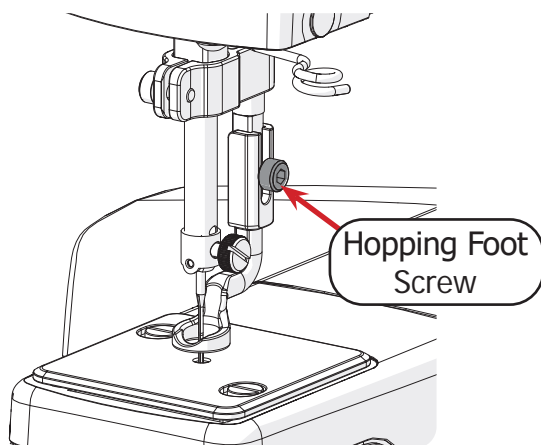

- 3 Slide the **hopping foot height tool** (shown in blue) underneath the hopping foot with the needle inside the slot.

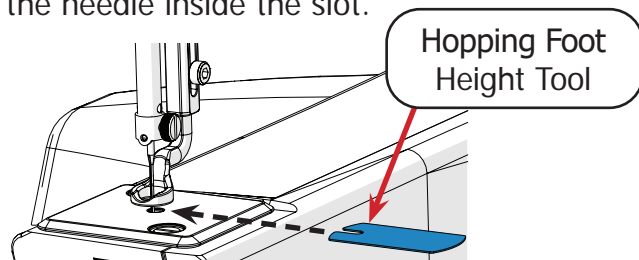

Note: The height tool prepares the machine for standard sized quilt batting and two layers of fabric. For thicker quilts, stack sheets of printing paper over the gauge to increase room underneath the hopping foot.

- 4 Lower the hopping foot until it rests on the height tool. Re-tighten the hopping foot screw with the 3 mm Allen wrench.

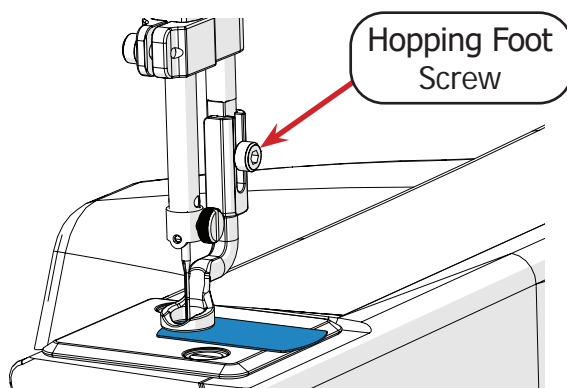

Rotation Instructions

The hopping foot can be rotated to improve line of sight. To rotate the hopping foot, please take the following steps.

- 1 Power off the machine.
- 2 Rotate the **hand wheel** to lift the needle from the hopping foot.

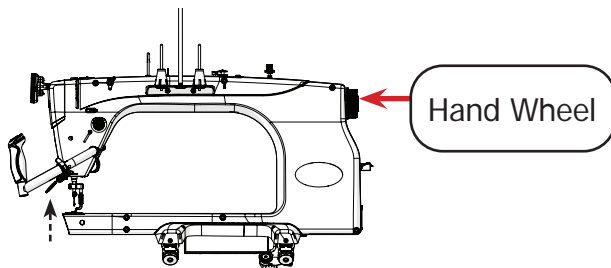

- 3 Use the 3 mm Allen wrench to remove the **hopping foot screw** and the **hopping foot**.

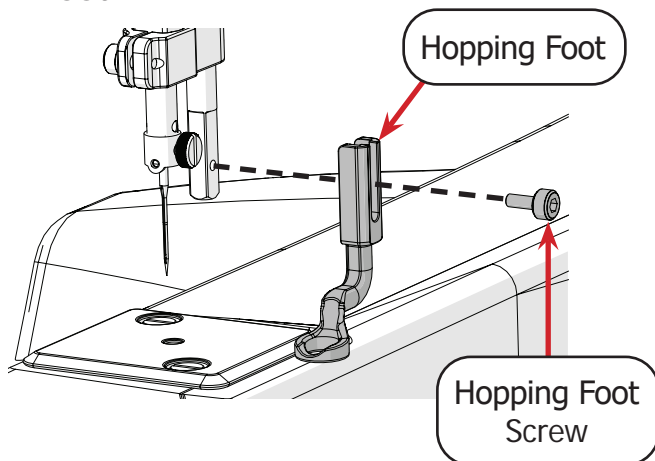

- 4 With the 3 mm Allen wrench, loosen the **collar screw** that holds the **hopping foot collar** to the press bar.

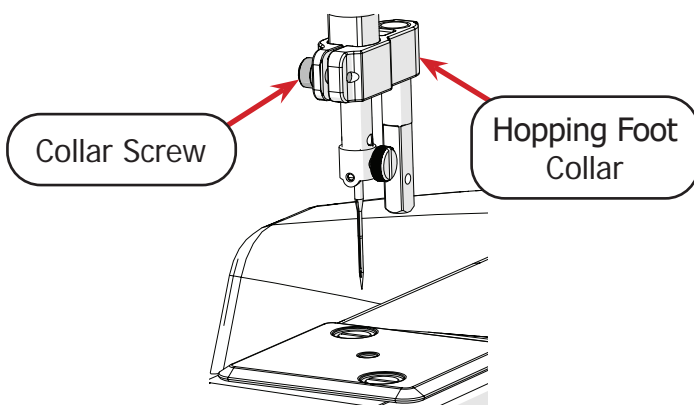

- 5 Drop the hopping foot collar below the **press bar** and turn it to the desired position.

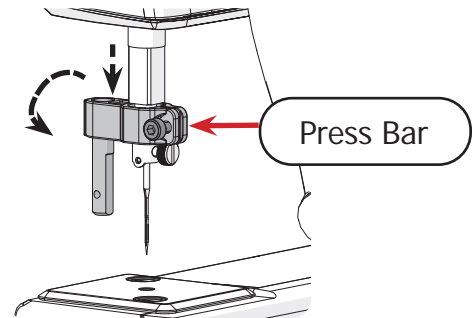

The hopping foot can be set to two positions:

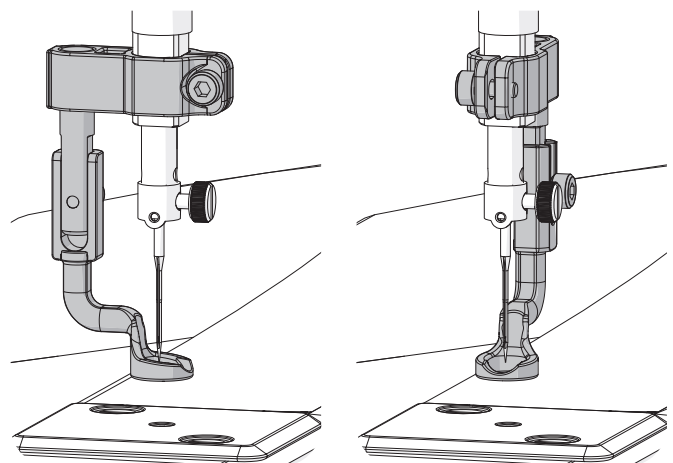

- 6 Lift the hopping foot collar back up to the **press bar** so that the bottom of the collar is even with the bottom of the press bar, and re-tighten the **collar screw**.

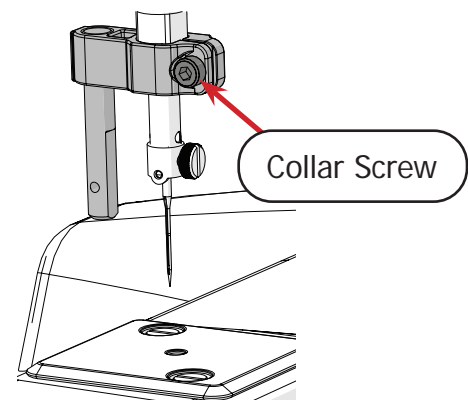

Part Four | Maintaining the Machine

Adjusting the Hopping Foot (Continued)

- 7 Slide the **hopping foot** into the collar and screw in place with the **hopping foot screw**.

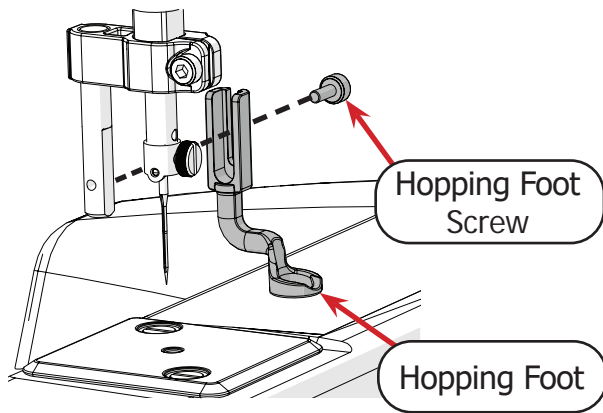

- 8 Double-check your hopping foot height (see page 96).

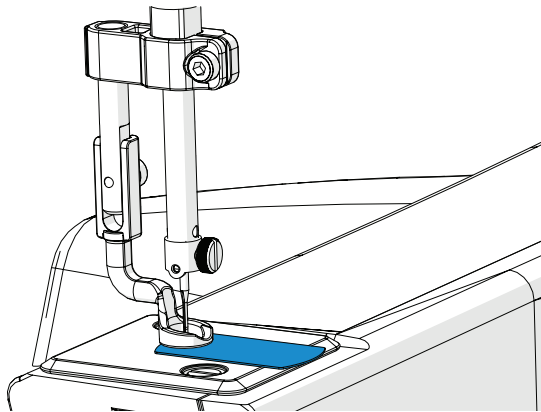

Removal Instructions

To remove the hopping foot for maintenance or to adjust the hopping foot angle, take the following steps:

- 1 Power off the machine.
- 2 Rotate the **hand wheel** to lift the needle from the inside of the hopping foot.

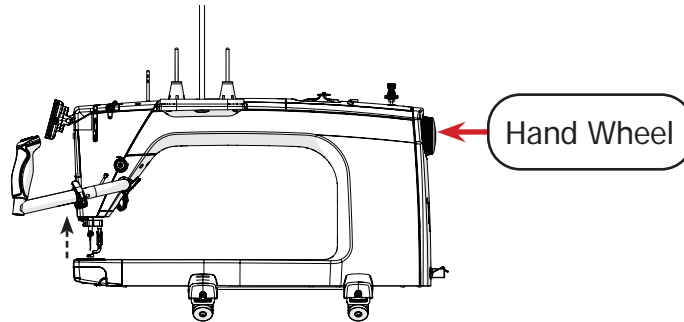

- 3 Use the 3 mm Allen wrench to remove the **hopping foot screw** and the **hopping foot**.

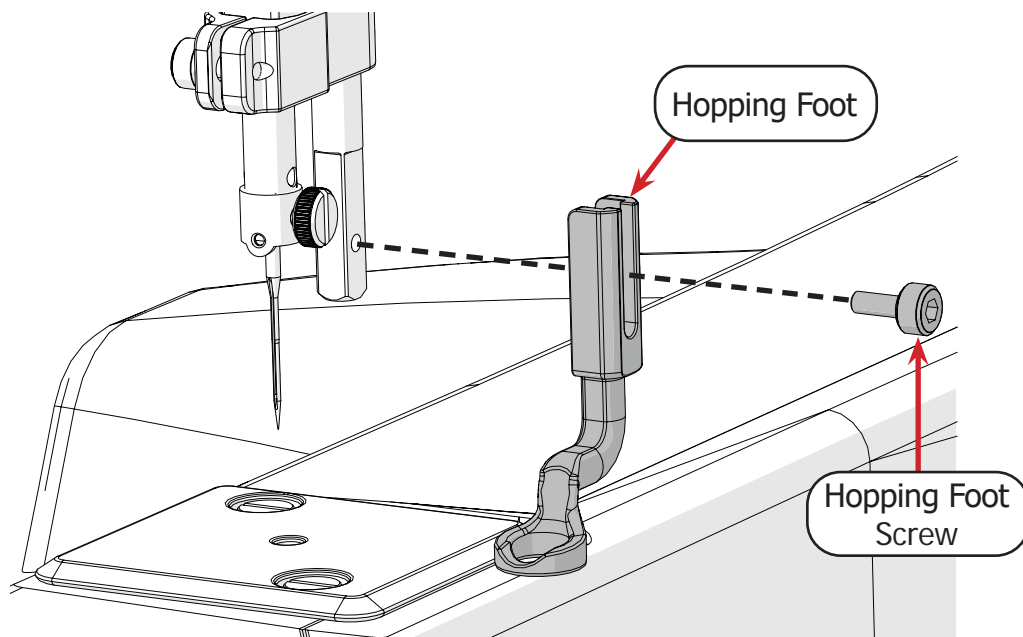

Installation Instructions

To install the hopping foot on your quilting machine, please take the following steps:

- 1 Power off the machine.
- 2 Slide the slot in the **hopping foot** onto the **hopping foot collar**. Use the 3 mm Allen wrench and **hopping foot screw** to tighten in place.

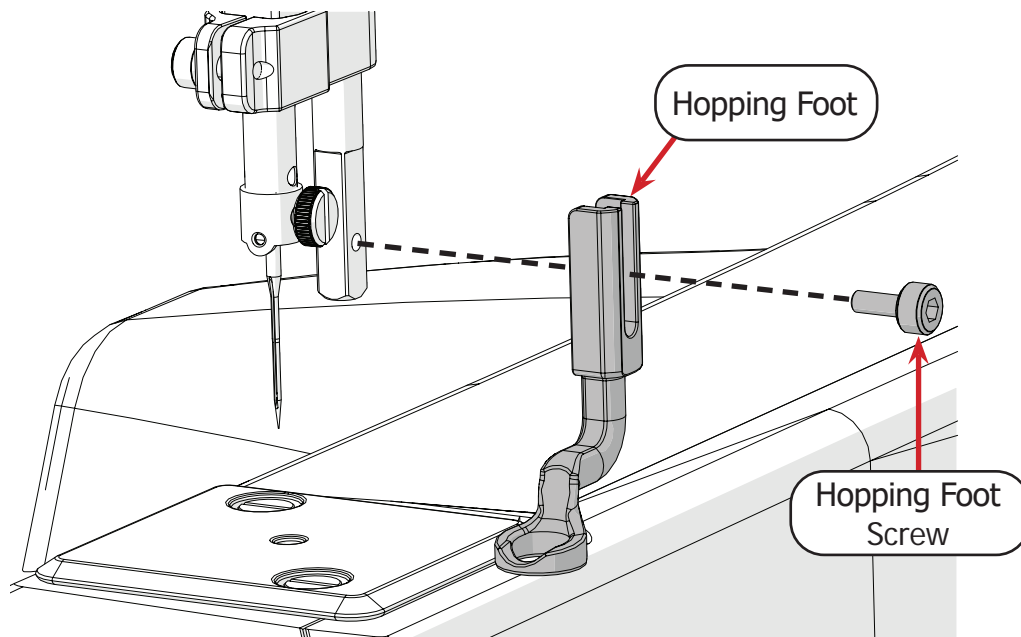

- 3 Adjust height as needed (see page 96).

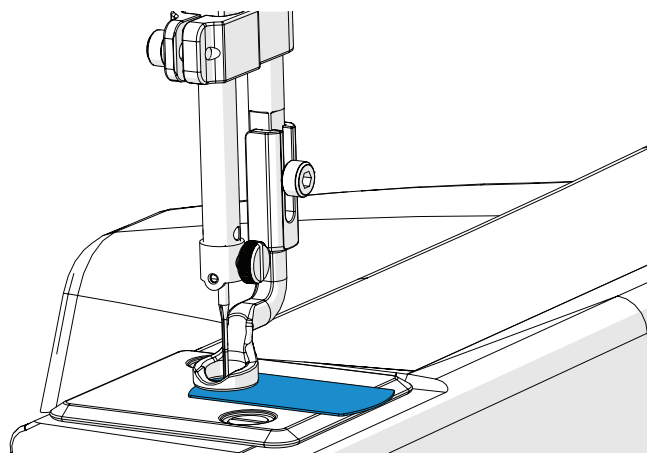

Reinstalling the Needle Plate

Parts & Tools Needed:

Flat-head Screwdriver

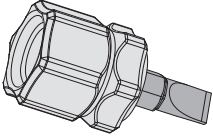

Box 1

Removal Instructions

To remove the needle plate from the quilting machine, take the following steps:

- 1 Power off the machine and raise the needle to the highest position using the **hand wheel**.

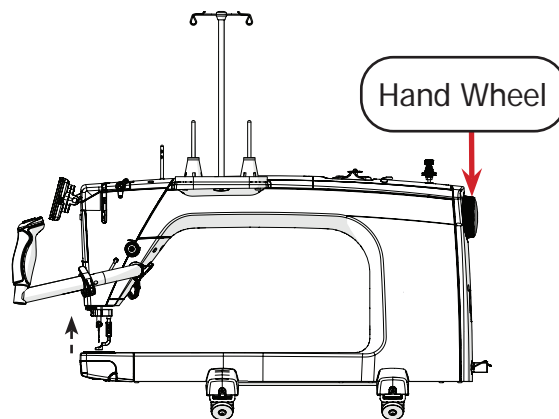

- 2 Use the flat-head screwdriver to remove the two **needle plate screws** (shown in gray).

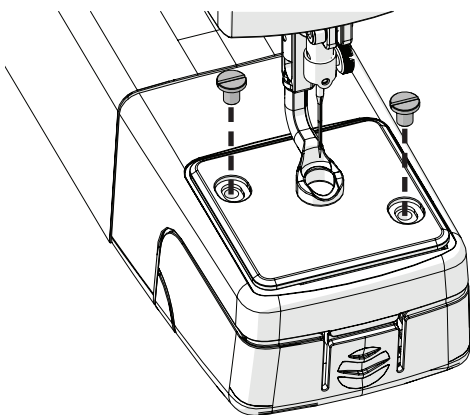

- 3 Slide the **needle plate** (shown in gray) from the machine.

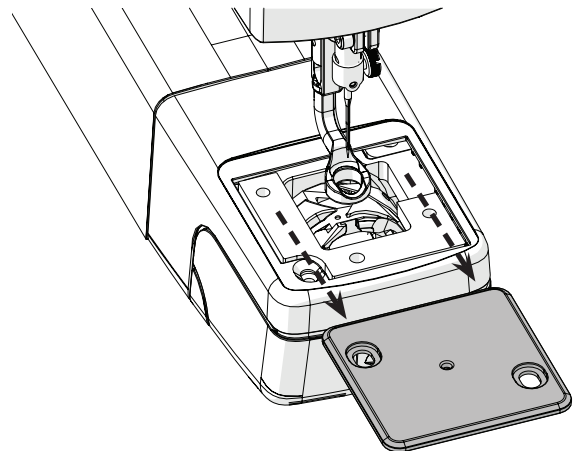

Installation Instructions

To install the needle plate onto the quilting machine, take the following steps:

- 1 Power off the machine. Raise the needle to the highest position using the **hand wheel**.

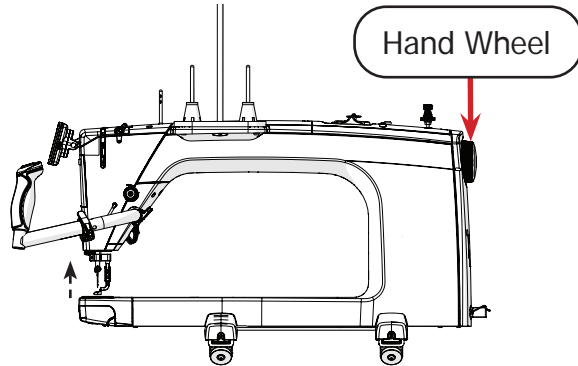

- 2 Slide the **needle plate** (shown in gray) onto the machine.

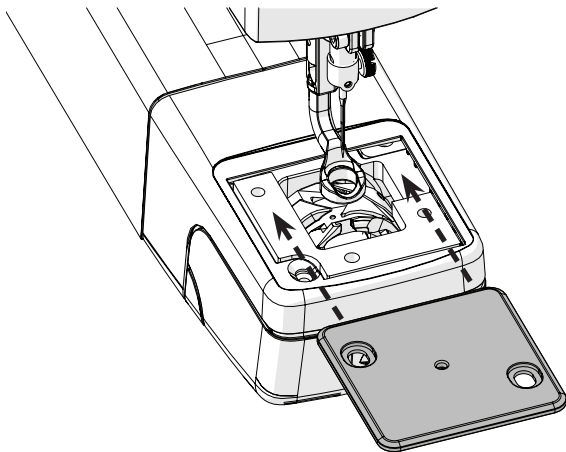

- 3 Align the screw holes on the needle plate with those on the machine.

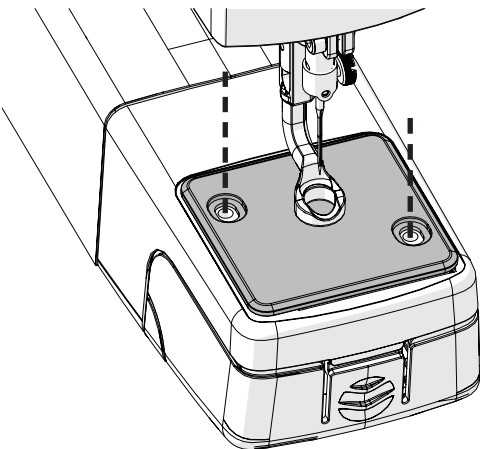

- 4 Slowly lower the needle with the hand wheel. The needle should slide into the center hole without contacting the needle plate.

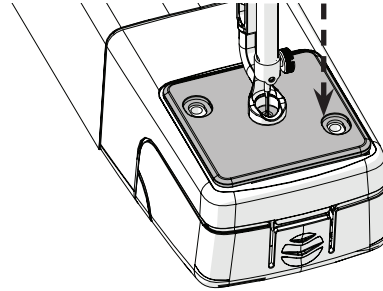

- 5 Place the two **needle plate screws** (shown in gray) into the plate. Make sure the needle plate is centered around the needle, and then tighten the screws with the flat-head screwdriver.

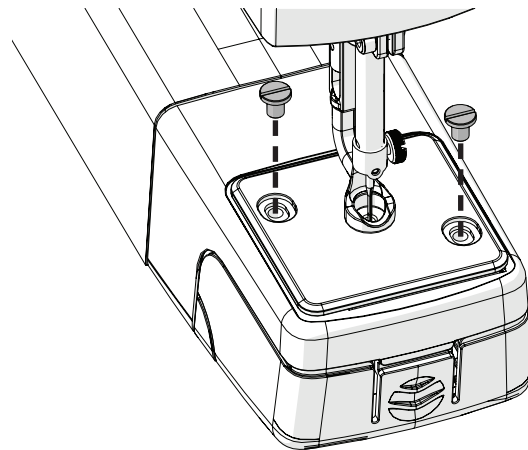

Repairs and Diagnostics

The instructions in this section should only be taken at the direction of a Grace Company support technician. If you are experiencing problems with your machine, please contact our technical support team:

- **Phone:** (800) 264-0644
- **Email:** support@graceframe.com

This section of the manual covers replacing the encoder spring, installing the hook holder, timing the machine, and checking the machine and display software versions.

Troubleshooting the Bobbin Wind	page 83
Replacing the Encoder Spring	page 85
Reinstalling the Hook Holder	page 88
Timing the Machine	page 91

Troubleshooting the Bobbin Wind

A quality bobbin wind is essential for a properly functioning machine and for setting your baseline thread tension. The thread on the bobbin should be smooth and evenly wound. The threads should be tightly packed together.

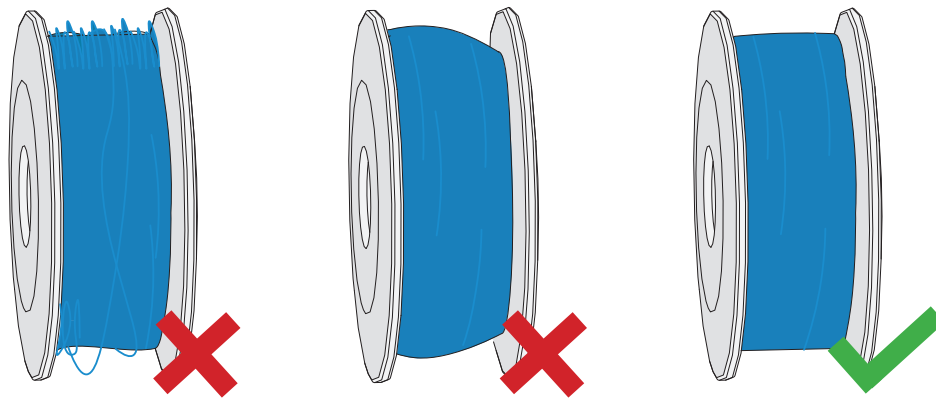

Bobbin Wound Too Loose

The tension of the bobbin wind is determined by the bobbin thread tensioner. Turn the knob one full rotation clockwise and re-test the bobbin wind. Repeat until the bobbin wind is tight and smooth.

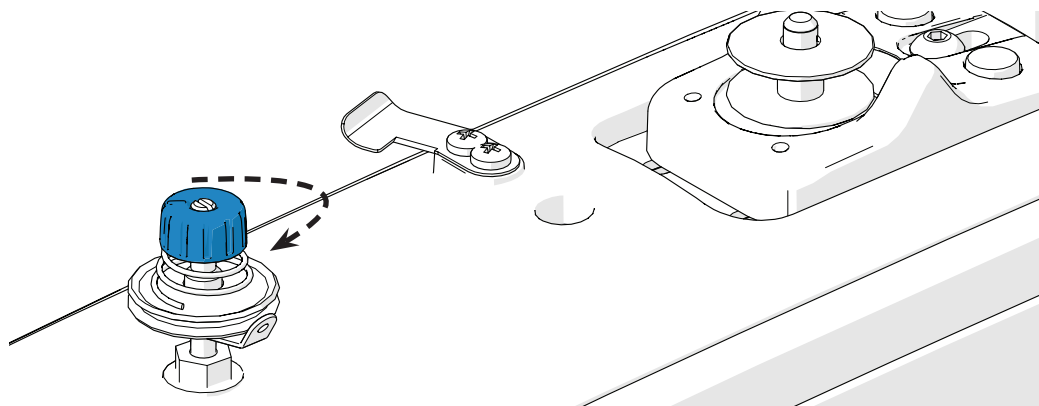

Bobbin is Filling to One Side

If the bobbin is filling to one side, the bobbin thread tensioner is positioned incorrectly and will need to be adjusted.

- 1 Determine the whether the bobbin is filling more toward the top or the bottom.



Troubleshooting the Bobbin Wind (continued)

- 2 Unthread the bobbin thread tensioner. With a 7 mm wrench or needle-nose pliers, loosen the **nut** at the base of the tensioner.

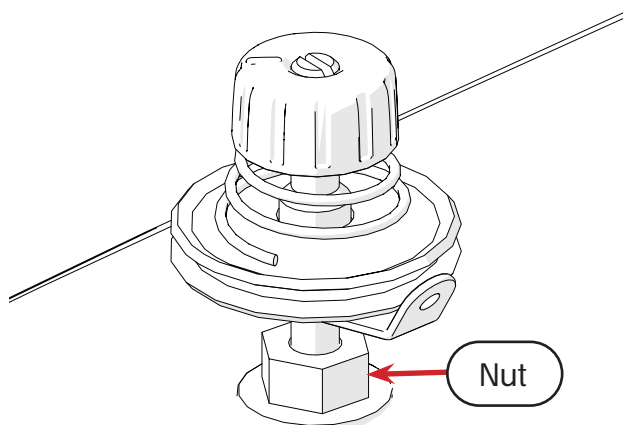

- 3 Turn the top part of the tensioner assembly (shown in blue) a full rotation to adjust the height of the tension discs.

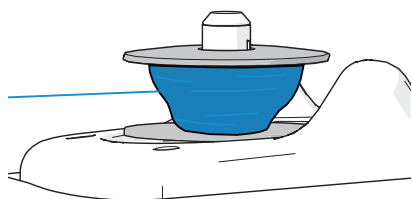

If the bobbin is filling more toward the top, turn the tensioner one full rotation clockwise and re-test.

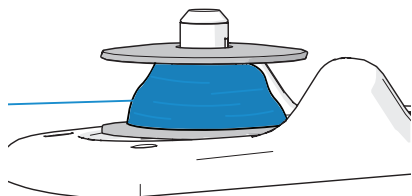

If the bobbin is filling more toward the bottom, turn the tensioner one full rotation counter-clockwise and re-test.

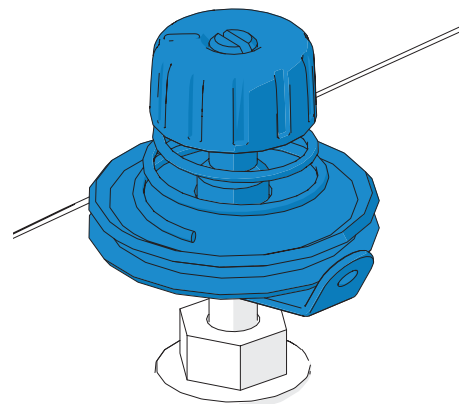

- 4 Once the bobbin is filling correctly, re-tighten the **nut**. Make sure the **thread guide** is on the correct side of the tensioner assembly.

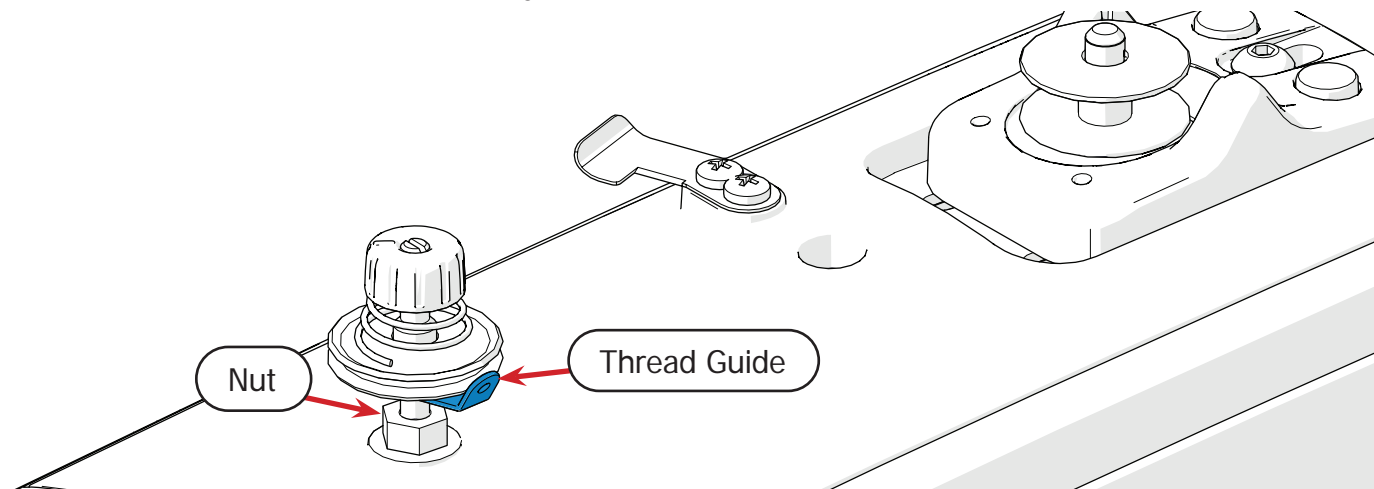

Replacing the Encoder Spring

Please speak to a Grace Company support technician before attempting these instructions.

Parts & Tools Needed:

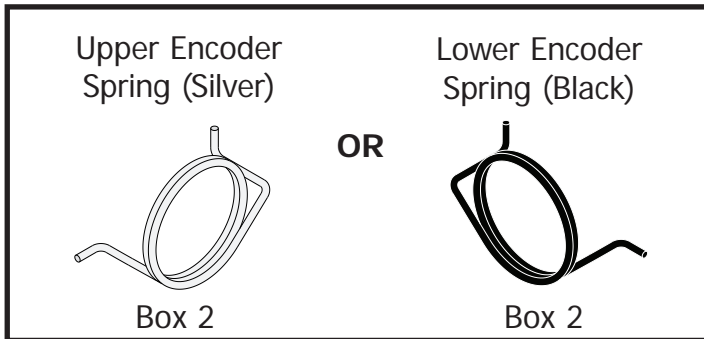

T-handle Allen Wrench 2.5 mm

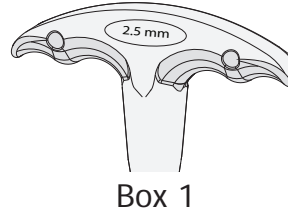

T-handle Allen Wrench 4 mm

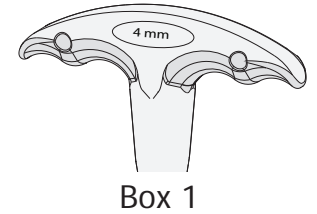

Instructions

If the encoder spring is over-tensioned, it may break and need to be replaced. To replace the encoder spring, take the following steps:

- 1 Determine the correct spring to use in the repair:

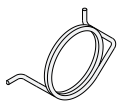

Upper Encoder: Attached to the wheel on the machine. Use the silver spring.



Lower Encoder: Attached to the wheel on the bottom carriage. Use the black spring.

- 2 Unplug the encoder cable from the machine.

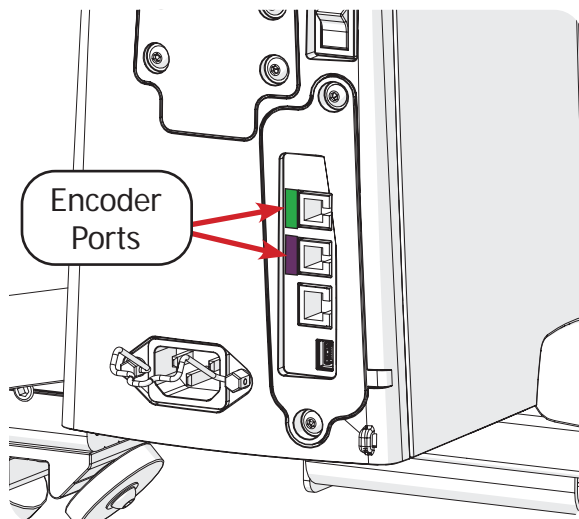

- 3 Loosen the **lock collar screw** with the 2.5 mm Allen Wrench until the **lock collar** (shown in blue) can twist freely.

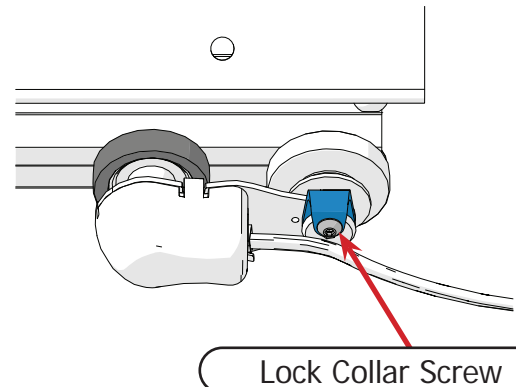

- 4 Use the 4mm Allen wrench to loosen the **encoder screw** and remove the encoder and wheel.

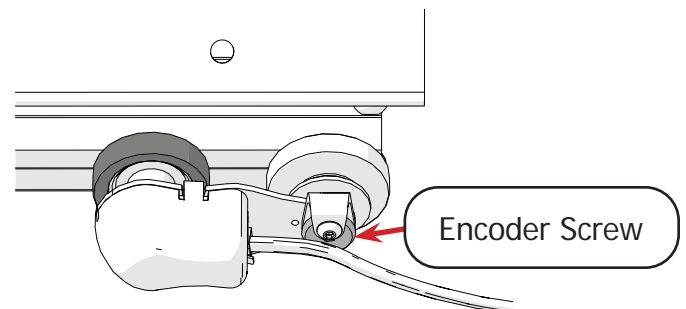

- 5 Remove the **plastic stop**, **wheel spacer**, **washer**, broken **encoder spring**, and **shoulder spacer** from the encoder.

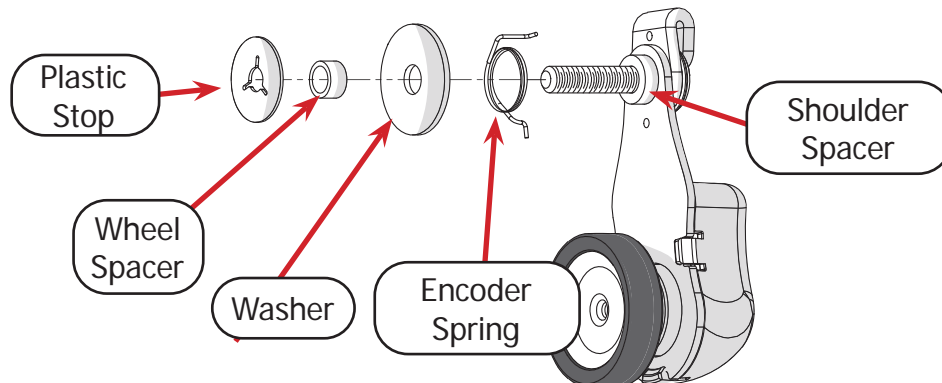

- 6 Pull on the **lock collar** to remove it from the encoder screw.

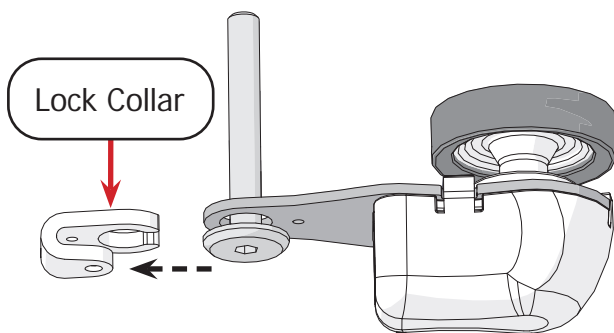

- 8 Place the **long arm** of the encoder spring arm into the hole on the encoder **lock collar**.

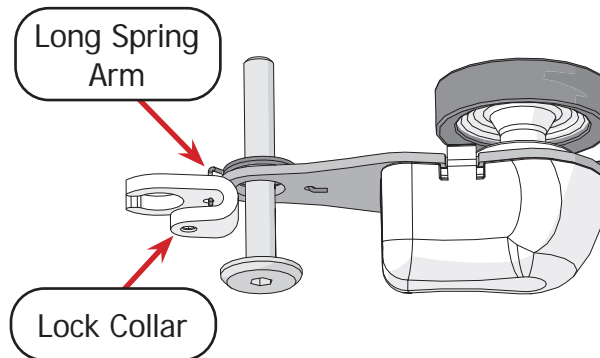

- 7 Place the replacement spring over the encoder screw, and insert the **short arm** of the spring all the way through the hole on the encoder base.

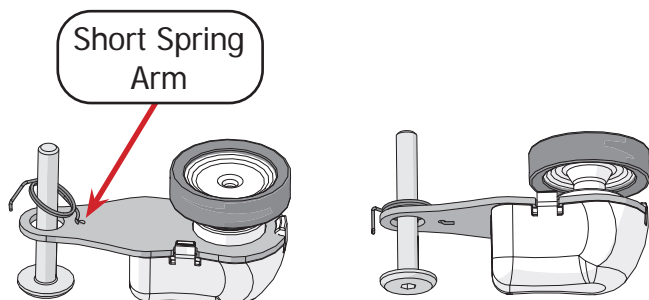

- 9 Without allowing the arm to slip out of the lock collar, rotate the collar until it wraps around the encoder bolt.

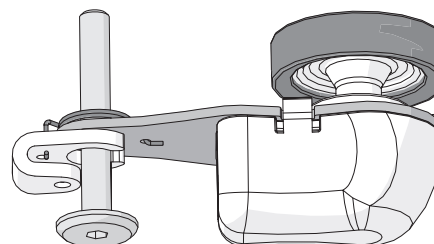

Replacing the Encoder Spring (Continued)

- 10 Adjust the screw and lock collar so the head of the screw slides in between the lock collar.

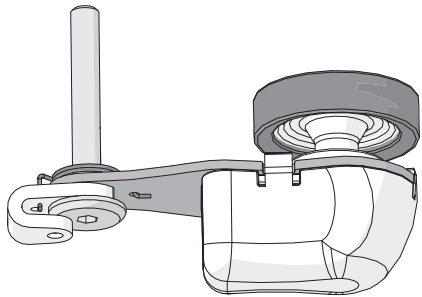

- 11 Slide the **shoulder spacer** onto the screw with the thinner side toward the head of the bolt.

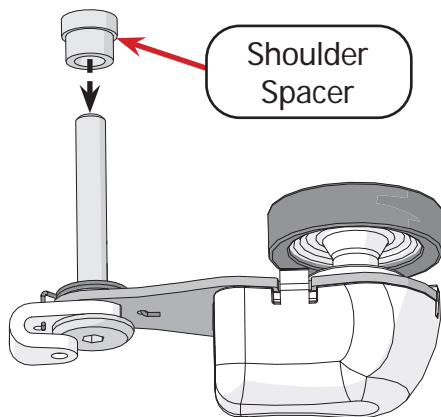

- 12 Next, place the **washer**, **wheel spacer**, and **plastic stop** onto the encoder screw.

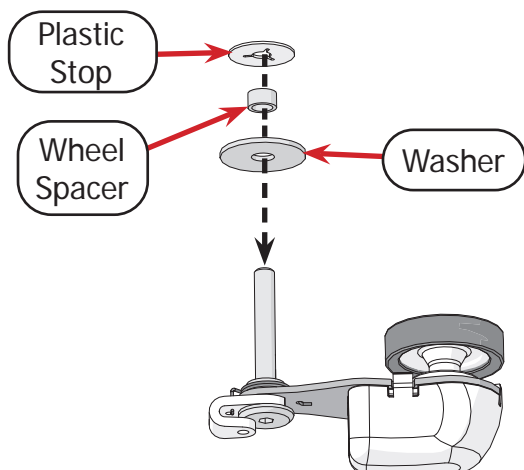

- 13 Complete the assembly instructions for the encoder you repaired.

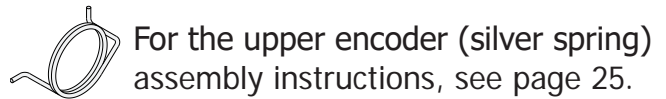

For the upper encoder (silver spring) assembly instructions, see page 25.



For the lower encoder (black spring) assembly instructions, see page 5.

Reinstalling the Hook Holder

Parts & Tools Needed:

T-handle Allen
Wrench 3 mm

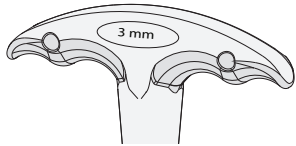

Box 1

Flat-head Screwdriver

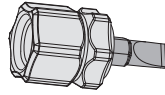

Box 1

Please speak to a Grace Company support technician before attempting these instructions.

Removal Instructions

The hook holder keeps the hook assembly in place. The following procedure should only be attempted if determined necessary by a Grace Company support technician. If done incorrectly, major machine problems can result.

- 1 Turn off the machine.
- 2 Rotate the **hand wheel** to raise the needle to the highest point.

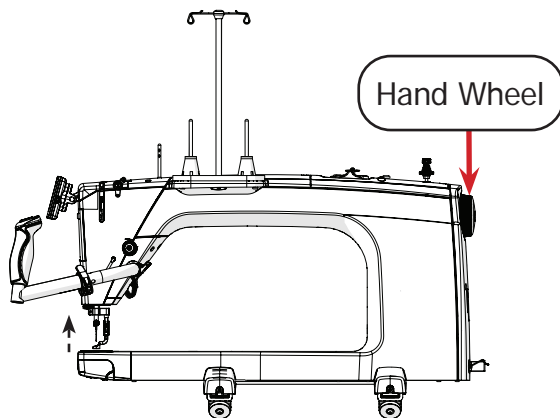

- 3 Press in on the hook assembly cover and down to open it.

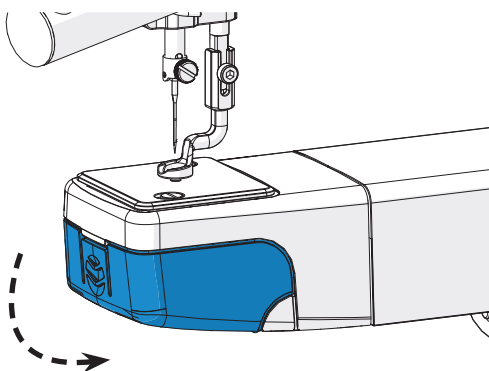

- 4 With the 3 mm Allen wrench, remove the **hook holder screw** (shown in gray) that attaches the hook holder to the machine.

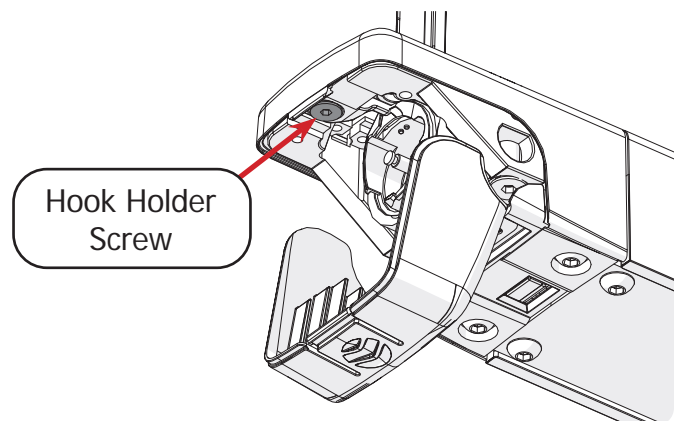

- 5 The **hook holder** will slide free of the machine.

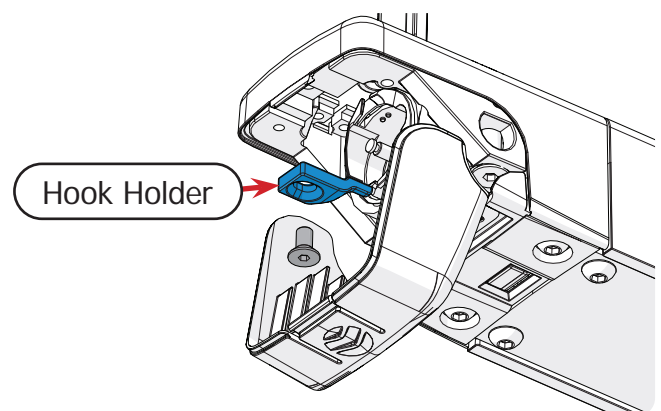

Installation Instructions

- 1 Turn off the machine.
- 2 Rotate the **hand wheel** to raise the needle to the highest point.

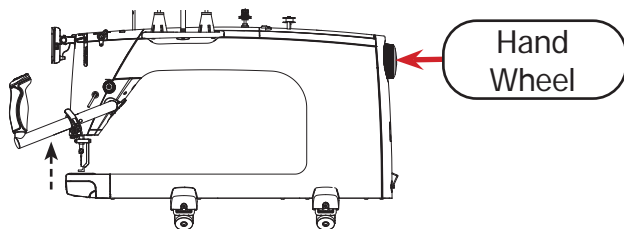

- 3 Remove the needle plate using the flat-head screwdriver (see page 66).

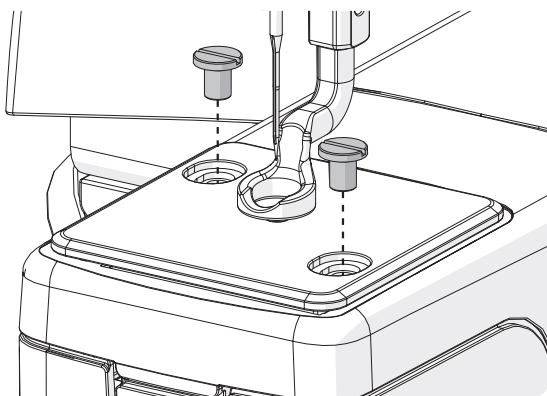

- 4 Remove the bobbin case from the hook assembly (see page 32).

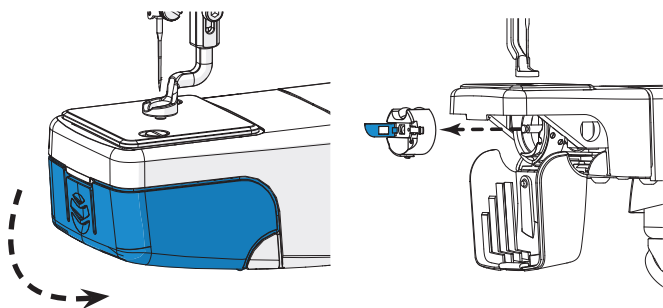

- 5 Turn the inside part of the **hook assembly** (shown in blue) so that the **positioning guide** is at the highest point.

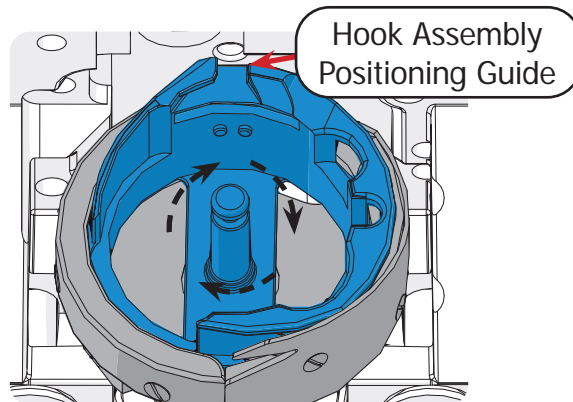

- 6 Slide the finger of the **hook holder** into the middle of the **hook assembly's positioning guide**.

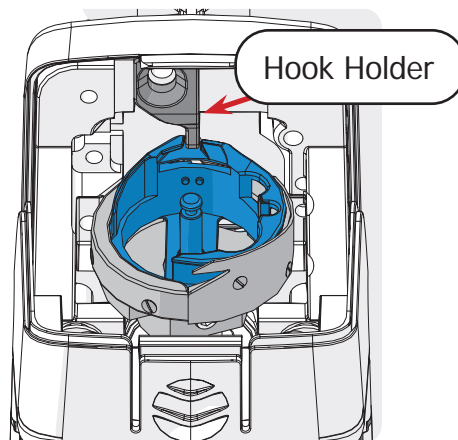

- 7 Attach loosely with the **hook holder screw**. Do not tighten.

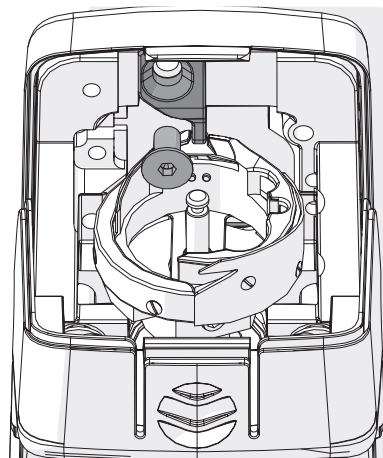

- 8 Align the **hook holder** with the inside edge of the **positioning guide**, as shown below.

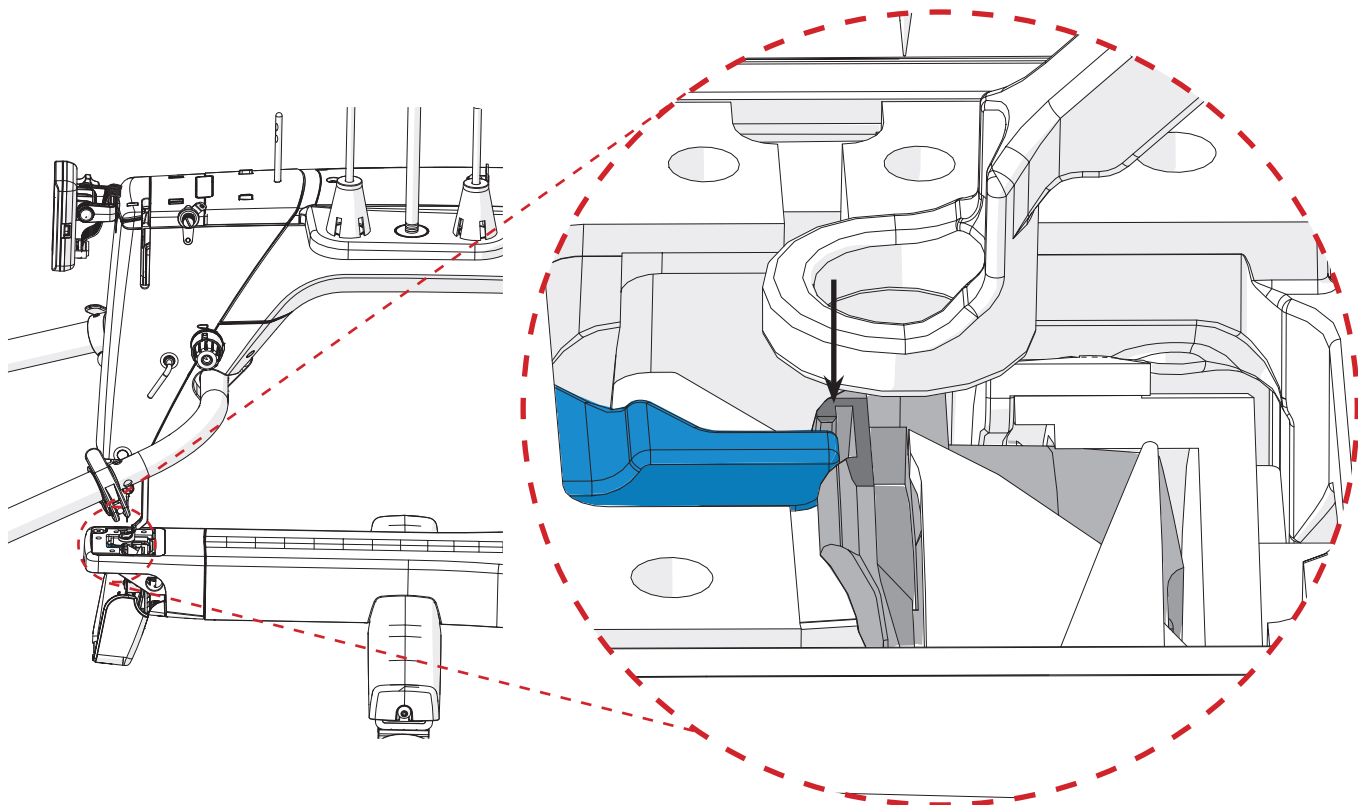

- 9 Tighten the hook holder screw to fasten the hook holder in place. The inside part of the hook assembly should no longer rotate freely by hand.

Timing the Machine

Please speak to a Grace Company support technician before attempting these instructions.

Parts & Tools Needed:

Flat-head Screwdriver

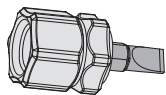

Box 1

T-handle Allen Wrench 2 mm

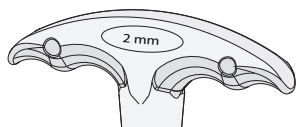

Box 1

Timing Spacer Tool

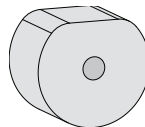

Box 1

Instructions

Timing your machine aligns the needle and hook assembly so that they are in the correct places during the creation of a stitch. Improper timing can result in damage to the machine and needle, or make sewing impossible. Please consult with a Grace Company support technician before attempting to adjust the timing on your machine.

- 1 Turn off the machine.
- 2 Check that your **needle** is not bent or damaged, and that it is inserted all the way into the needle bar (see page 73).

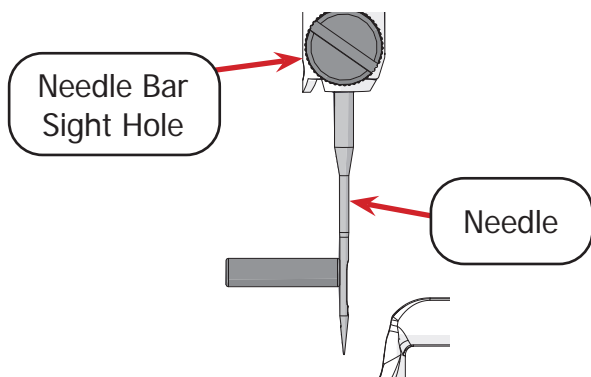

- 3 Remove the bobbin case from the hook assembly (see page 32).

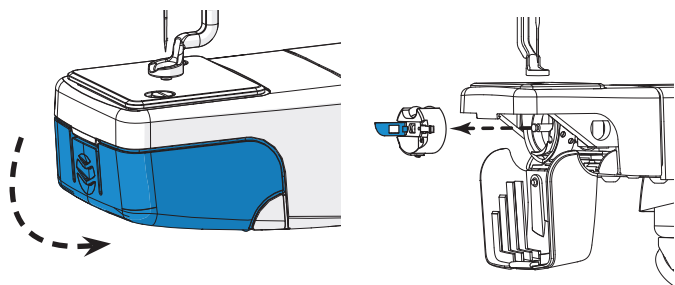

- 4 Remove the needle plate (see page 80).

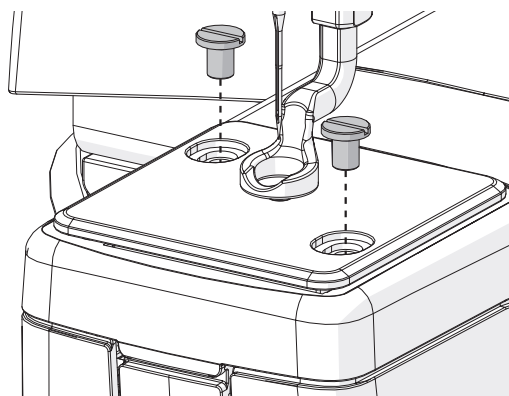

- 5 Look into the machine's **timing cut-out** and turn the hand wheel. The **hook assembly** will rotate.

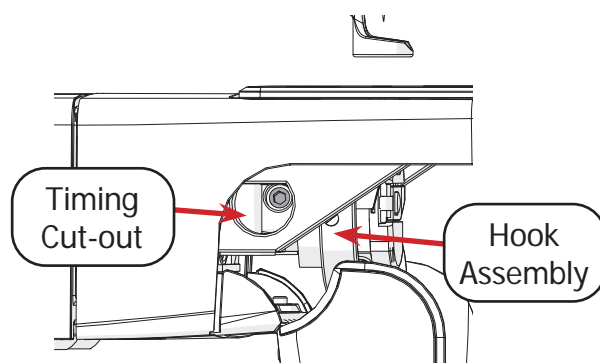

- 6 As each of the **3 set screws** aligns with the cut-out, loosen them with the 2 mm Allen wrench.

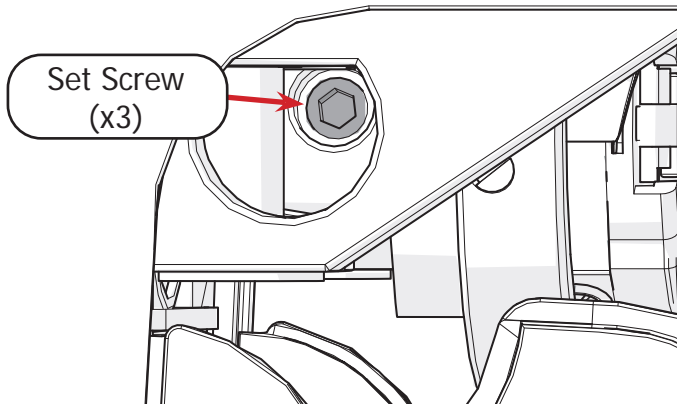

- 7 The **outside** part of the hook assembly (shown in blue) now rotates by hand. Turn the outside part of the hook assembly so that the **hook** is at the top.

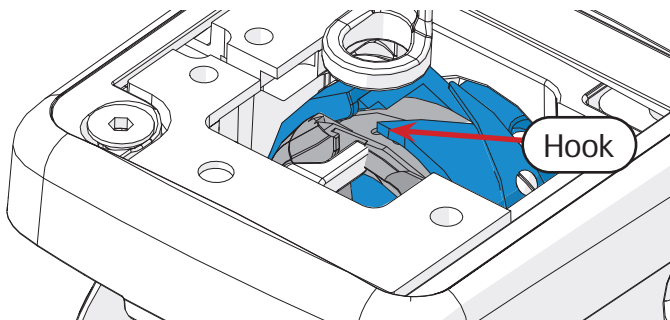

- 8 Carefully rotate the hand wheel to drop the **needle** (shown in gray) all the way to the lowest point. Continue rotating the hand wheel the same direction. The **needle** should begin to raise up.

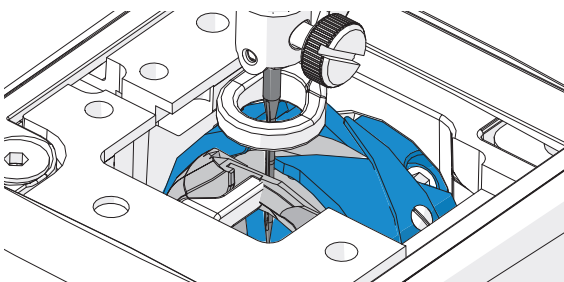

- 9 Stop raising the needle once the eye is about level with the **hook** (shown in blue). Do not continue to raise the needle. If the needle reaches the top of its rotation (over the hopping foot), start over at step 8.

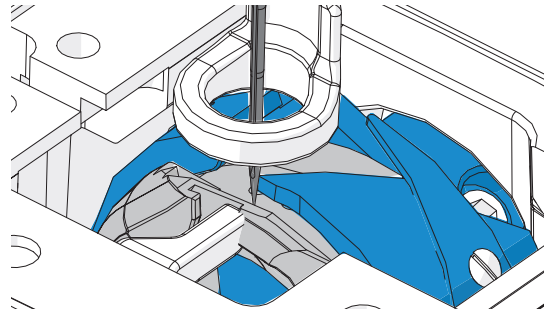

- 10 Slip the **timing spacer** (shown in blue) into the hook assembly.

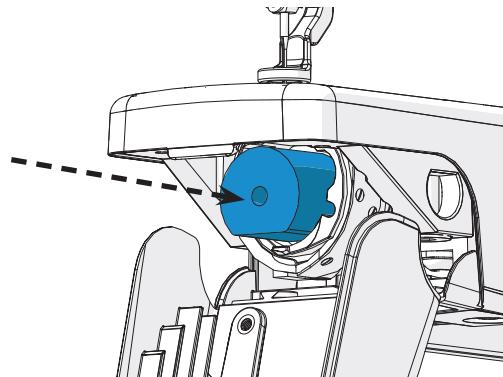

- 11 Turn the hand wheel the opposite direction to bring the **needle** back down until it rests on top of the **timing spacer**. Do not let the **needle** rise to the top before bringing it back down or you will need to repeat steps 8–11.

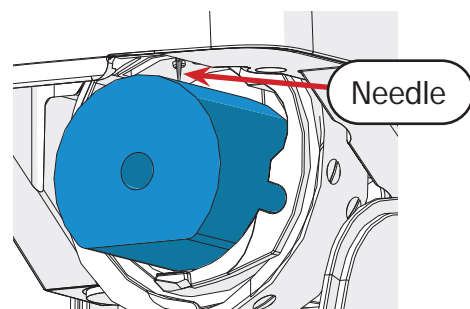

Part Four | Repairs and Diagnostics

Timing the Machine (Continued)

- 12 Position the tip of the **hook** (shown in blue) in the middle of the back of the **needle** (shown in gray). This is easier to see from the back of the machine.

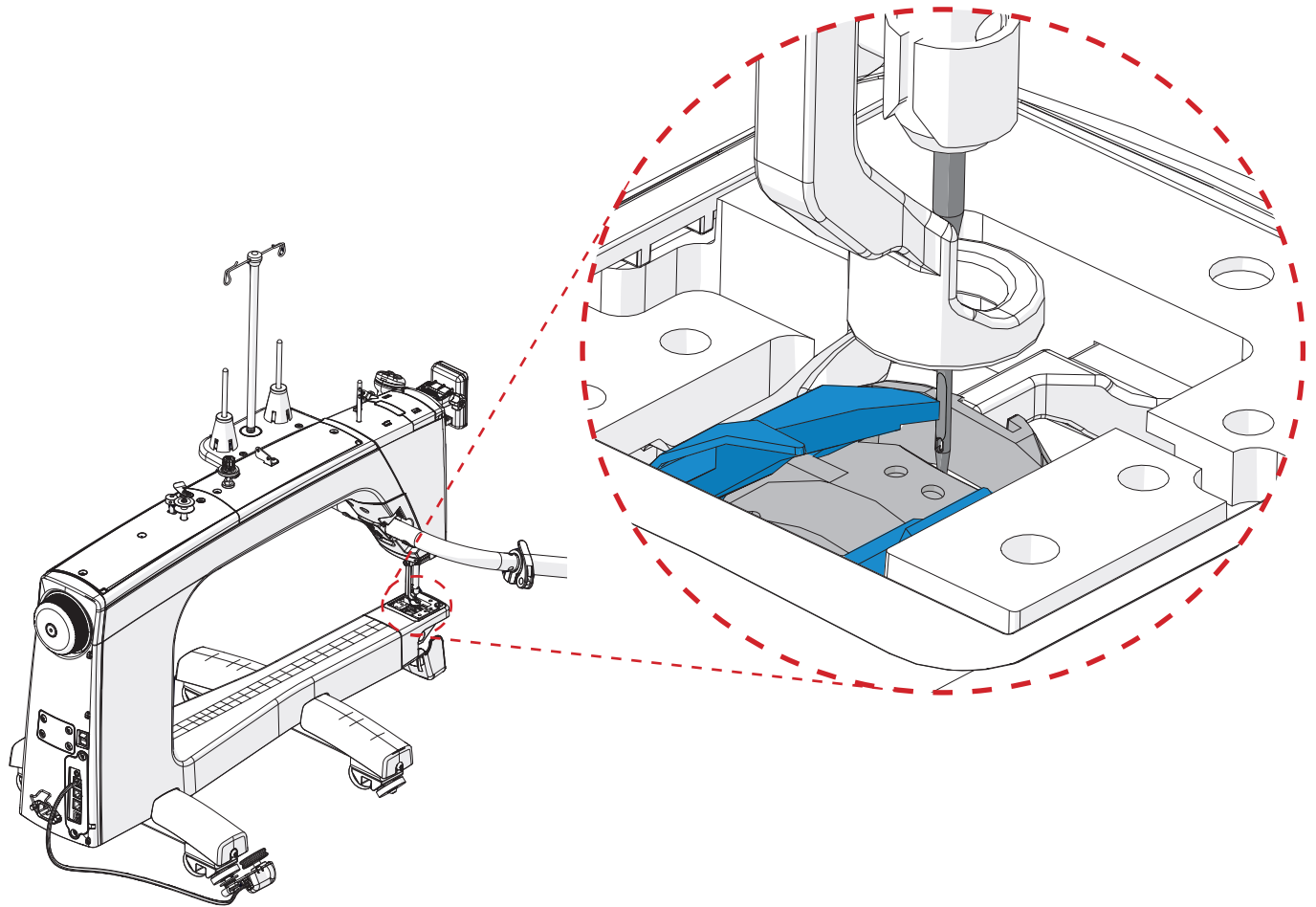

- 13 Pull the hook assembly toward the front of the machine until the hook is as close to the needle as possible without touching

- 14 Use the 2 mm Allen wrench to tighten one of the three **set screws** through the timing cut-out window on the left.

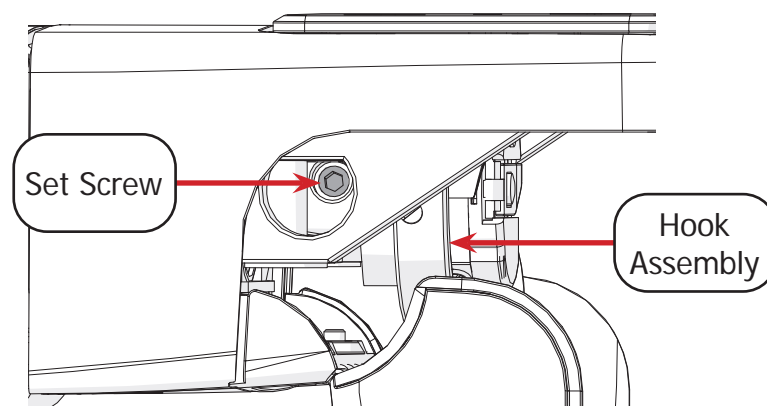

- 15 Turn the timing spacer tool until the flat side is facing up and then remove it from the machine.

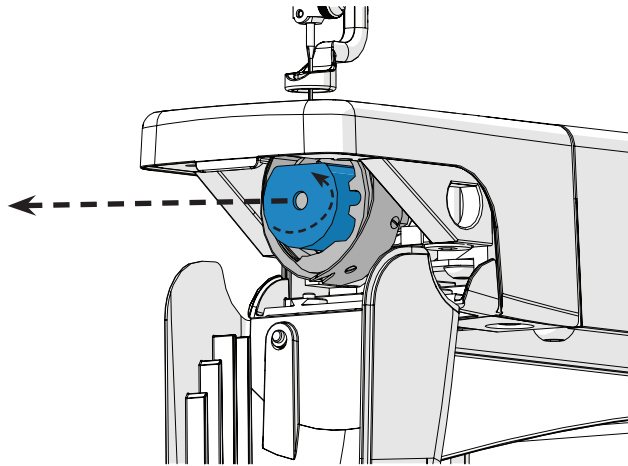

- 16 Turn the hand wheel a full rotation to listen for clicking noises and to ensure the needle does not bend or hit the hook.
- 17 Tighten the two remaining **set screws** through the timing cut-out.

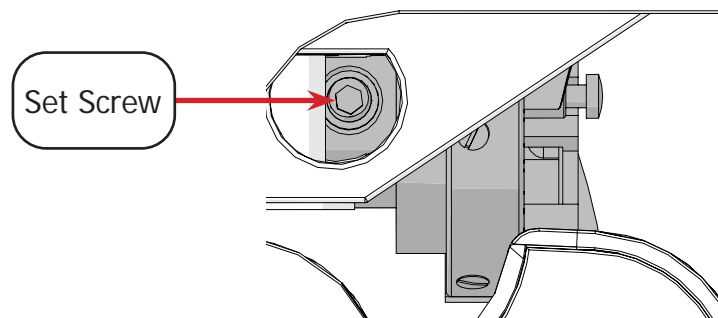

- 18 Replace and align the needle plate (see page 80). Make sure the needle is in the center of the needle plate.
- 19 Replace the bobbin case (see page 32).
- 20 Replace the hopping foot and adjust hopping foot height (see page 96).
- 21 Test the machine and listen for any unusual noises. If there are any skipped stitches, the hook is too far away from the needle. If the thread breaks, the hook is too close to the needle.

Appendix

This section of this manual covers additional information on quilting with your machine.

Choosing Your Needle	page 96
Choosing your Thread	page 96
Choosing Your Fabric and Batting	page 101
Troubleshooting Guide	page 102
Index	page 104

Choosing Your Needle

Using the wrong type of needle, or using a needle that is bent, broken, or blunt, can damage the fabric, the machine, and needle. For best results:

- Use the recommended needle style for your machine (see below).
- Use the needle size appropriate for the weight and type of thread you're using (see below).
- Never use a needle that is dull, bent, burred, or damaged.
- Use multi-directional needles.
- Change your needle after 8 hours of use and at the beginning of each project.

Needle Style

The following are the recommended needle styles for your machine:

- DPX5 MR
- 134 MR
- 1955 MR

Needle Sizes

Choose the size of your needle based upon the thread you're using. Thicker thread requires a thicker needle. Remember, the thicker the thread, the lower the thread weight (wt.) number.

Needle Size	Thread Size and Type
14 / 90	<ul style="list-style-type: none"> • mono-filament • 100 wt. silk • 60 wt. polyester
16 / 100	<ul style="list-style-type: none"> • mono-filament • 60 wt. polyester or cotton • 50 wt. cotton
18 / 110	<ul style="list-style-type: none"> • 50 wt. polyester • 40 wt. cottons and polyester • 30 wt. cotton and polyester
20 / 125	<ul style="list-style-type: none"> • 30 wt. or heavier of any thread

Needle Diagram

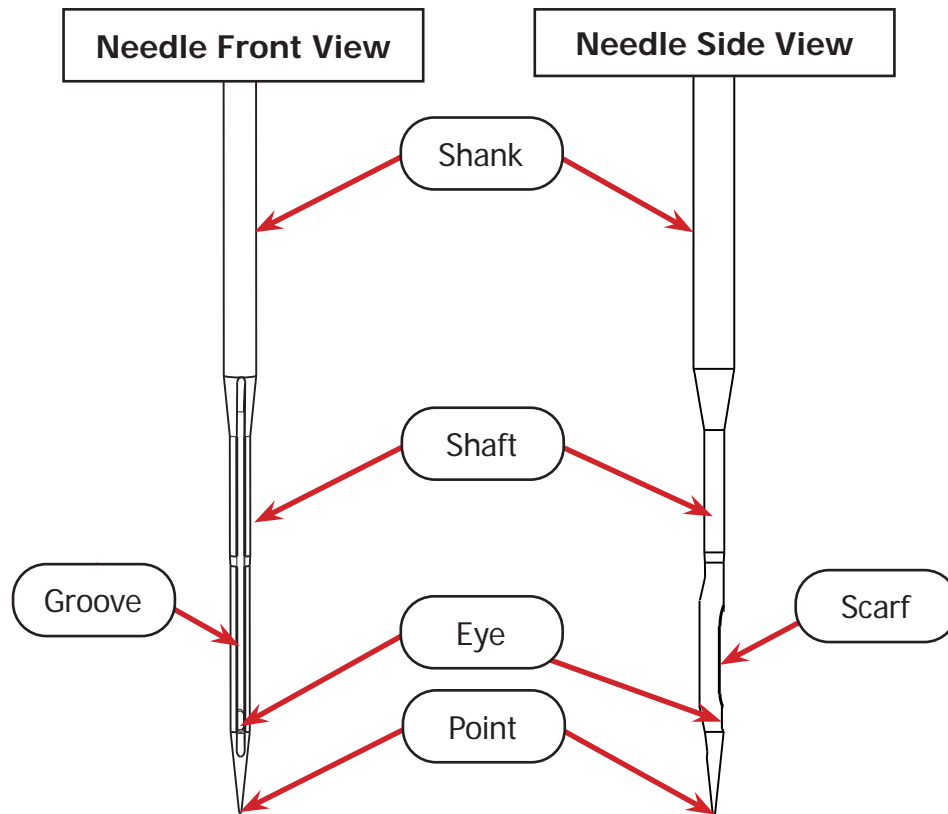

- **Shank:** Where the needle bar grasps the needle.
- **Shaft:** The long, narrow part of the needle. Needle size is based upon the diameter of the needle shaft.
- **Groove:** Reaching from the top to the bottom of the needle shaft, the groove allows thread to pass through the fabric more easily and without getting damaged.
- **Eye:** Hole near needle point where the needle is threaded.
- **Scarf:** A cut-away on the back of the needle that allows the needle to fit smoothly within the hook assembly when quilting.
- **Point:** The sharp end of the needle. Choose the type of needle point to fit your project, and always replace your needle once the point is dull.

Choosing Your Thread

Choosing the best thread for your project is just as important as choosing the correct needle. Good thread is strong and can pass the “Yank Test” (see “Task 11 - Threading the Machine” on page 34). It holds its color well over time (colorfastness), and uses long fibers (extra-long staple) that resist pilling or creating lint.

Thread type and size determines not only which needle size to choose and what the thread tension must be set to on your machine, but also how visible the thread is on the project.

For best results:

- Use a cone-style thread unless you have the thread spool accessory for your machine.
- Test the strength of thread before use with the “yank test” (see “Task 11 - Threading the Machine” on page 34).
- Practice using new thread on spare quilting materials to find the ideal thread tension. Write this information down and store it with your thread for later reference.
- Keep thread out of sunlight to prevent fading, and do not store near extreme temperatures.
- Select thread that is ideal for the fabric you’re using (see the chart below).
- Avoid using different thread type for the top thread than you’re using for the bottom thread.

Thread Type Guide

Threads can be multiple strands, called plies, spun together, or it can be a single ply. The fibers that make up the ply can come from many sources, but the most common threads used in quilting are made from cotton, polyester, and silk. The unique properties of each material make some threads better suited for use on some fabrics than others.

Thread Type	Ideal Fabric
Cotton	<ul style="list-style-type: none"> • Cotton • Linen • Rayon
Polyester	<ul style="list-style-type: none"> • Knit or Stretch • Woven synthetic
Silk	<ul style="list-style-type: none"> • Silk • Wool • Basting thread for all fabrics

Thread Size

The thickness of the thread is called the weight (wt.). This number is usually stamped on the edge of the top or bottom of the thread cone. Notice that as the thread becomes heavier and thicker, the weight decreases:

- 60 weight: Very thin, fine thread that will blend in to the fabric.
- 40 weight: Thicker thread that will show up on the fabric.

Note: choose matching weight and thread type when picking top and bottom (bobbin) threads.

Tip: Not all manufacturers will have the same sizing method for their thread. Threads can be measured by weight, tex, denier, or scaling that is unique to its brand. Take the time to understand how the sizing works for a brand you're considering, and keep a few common sewing rules in mind:

- The thicker the thread, the larger the needle required. A needle that is too thin can shred thread.
- The thinner the thread, the smaller the needle should be. A needle that is too large will cause uneven stitching and can leave holes in the fabric.

Thread Processing

Sometimes thread is processed to change its properties. The chart below lists the processes common to cotton and polyester. No extra processing or treatments are typical for silk.

Thread Type	Processing
Cotton	<ul style="list-style-type: none"> • Mercerized: Treated to improve strength and colorfastness. • Glazed: Waxed or coated to give a polished appearance. The coating may rub off and build up in machine. • Gassed: Exposed briefly to a gas flame to burn away fuzz and lint, giving a smooth appearance.
Polyester	<ul style="list-style-type: none"> • Lubricated: Treated with lubricant to reduce friction. Avoid thread that is oily to the touch. • Bonded: Treated with resin to increase strength. This is typically used for heavy-duty applications, such as upholstery.

Our Recommended Thread

Finesse thread is specially-designed for quilting by the Grace Company. It can be used with domestic (sewing) and quilting machines, and comes in 60 colors.

- 100% Polyester, 3-ply thread
- 1,500 yards mini-cone
- 50 wt.
- 110/18 or 100/16 quilting machine needle
- Topstitch 90/14 sewing machine needle

3283 Snow White	3293 Charcoal	2979 Rainbow	2989 Prism	2999 Cherry Blossom	3009 Deep Forest Green
3284 Pearl White	3294 Midnight Blue	2980 Sunny Spring Day	2990 Tropical Sunset	3000 Candy Apple	3010 Vintage Turquoise
3285 Light Wool	3295 Obsidian	2981 Strawberry Lemonade	2991 Aurora Lights	3001 Pomegranate	3011 Seaside Teal
3286 Ice Blue	3296 Marigold	2982 Pastels	2992 Mango Salad	3002 Dusk Rose	3012 Ocean Wave
3287 Pink Rose	3297 Leafy Green	2983 Raspberry Ice	2993 Camp Fire	3003 Cotton Candy	3013 Bright Blue Sky
3288 Lilac	3298 Blue Sapphire	2984 Circus Tent	2994 Mountain Jungle	3004 Tangerine Punch	3014 Lavender Blossom
3289 Light Sand	3299 Magenta	2985 Twilight Pink	2995 Desert Flower	3005 Grapefruit	3015 Amethyst
3290 Thicket Brown	3300 Amber	2986 Mauve Orchid	2996 Primary School	3006 Lemon Zest	3016 Mountain Mist
3291 Desert Tan	3301 Royal Purple	2987 Blueberries	2997 Mojito	3007 Light Spearmint	3017 Riverbed Slate
3292 Smokey Quartz	3302 Ruby Red	2988 King of Atlantis	2998 Florence	3008 Green Tea	3018 Canyon Shale

Choosing Your Fabric and Batting

Fabric

Some fabrics are not recommended for use with the quilting machine. Thick fabrics, such as denim or leather, have a lot of resistance that can bend or snap a needle, and misalign or break internal machinery. When quilting, avoid any fabrics that are difficult to pierce, and take care that the fabric layers of the quilt are well balanced .

Batting

To choose the best batting for your project, consider the look and feel of the quilt that you're going for. Batting thickness is measured by its loft. A low loft batting is thinner and lighter, ideal for a quilt with a flatter appearance. High loft batting should be used if a fluffy, full quilt is the goal.

Typically, wool batting is the thickest batting while bamboo is the lightest. Wool provides the most warmth, followed by polyester, and then cotton.

Troubleshooting Guide

Issue	Cause(s)	Solution
Machine won't turn on.	Loose cables	Check that all cables are securely plugged in (page 27).
	Machine is not turned on	Check power button is pressed down on right side (page 27).
	If problem persists, please contact a Grace Company support technician. Call (800) 264-0644 .	
Stitches are skipped.	Damaged needle	Check needle (page 73).
	Machine improperly threaded	Check that all tensioners and guides were threaded correctly (page 34).
	Bobbin wound or threaded incorrectly	Check that the bobbin was inserted the correct direction in the case (page 32).
	Incorrect thread tension	Adjust top thread tension (page 57). Adjust bottom thread tension (page 29).
	Hopping foot incorrect distance from needle plate	Check hopping foot height distance with height tool (page 96).
	If problem persists, please contact a Grace Company support technician. Call (800) 264-0644 .	
Thread is breaking.	Damaged needle	Check needle (page 73).
	Incorrect thread tension	Adjust top thread tension (page 57). Adjust bottom thread tension (page 29).
	Machine improperly threaded	Check guides and tensioners for accidental double-wrapping (page 34).
	Stitching in place too long	Keep machine moving to avoid stitch build-up in one place, or switch to regulated precise quilting mode (page 45).

Issue	Cause(s)	Solution
Thread is breaking.	Bobbin inserted incorrectly	Check bobbin is the correct direction in the case and inserted firmly (clicked) into the machine (page 32).
	Debris on tension discs	Clean the machine (page 69).
	Burred bobbin	Check bobbin for sharp edges. Contact your dealer to replace if needed.
	Needle plate is rubbing needle	Check that needle plate is centered and does not hit needle (page 80).
	If problem persists, please contact a Grace Company support technician. Call (800) 264-0644 .	
Machine is running loud.	Machine and/or hook assembly needs oiling	Oil the machine and hook assembly (page 69).
	Bobbin winder is on	Press the "off" button on the bobbin winder (page 29).
	If problem persists, please contact a Grace Company support technician. Call (800) 264-0644 .	
Thread is bunching up in hook assembly (bobbin case area).	Bobbin wound or threaded incorrectly	Check that the bobbin was threaded correctly and inserted the correct direction in the case (page 29).
	Machine improperly threaded	Check that all tensioners and guides were threaded (page 34).
	Incorrect thread tension	Adjust top thread tension (page 57). Adjust bottom thread tension (page 29).
	Bobbin case has damaged or missing spring	Check inside bobbin case to see spring. Contact your dealer to replace if needed.
	If problem persists, please contact a Grace Company support technician. Call (800) 264-0644 .	

Index

Symbols

2.4 inch touch display	19
2.5 mm T-handle Allen wrench	4, 19, 21, 22, 80
2 mm T-handle Allen wrench	86
3 mm T-handle Allen wrench	72, 83
4 mm T-handle Allen wrench	4, 8, 14, 16, 19, 22, 80

B

back left wheel base cover	xi, 14
back right wheel base cover	xi, 14
back wheel base assembly	8
basting	48
batting	96
bobbin	26, 29
bobbin case	29
bobbin fill adjustment	27
bobbin tension	30
bottle	66
bottom carriage	4
bottom case tension	30

C

cleaning	66
color theme	50
controls	41
cruise quilting mode	44

D

dimensions	iv
display	19
display cable port	vii
dual-wheel bottom carriage	4

E

electrical	i, iv, 24
encoder	22, 80
encoder port	vii, 23
encoder spring	80

F

fabric	96
features	iv
Finesse thread	95

firmware	59
flat-head screwdriver	77, 83, 86
front left wheel base cover	xi, 14
front right wheel base cover	xi, 14
front wheel base assembly	8

G

getting started	60
grounding instructions	ii
guide loops	27, 33

H

handlebar adjustment	16
handlebar assembly	16
handlebar controls	41
hand wheel	v
hook assembly	vi, 83, 86
hook holder	83
hopping foot	72
hopping foot height tool	72

I

included parts and tools	ix
--------------------------------	----

L

large thread tensioner	54
layout	v
leg cover	14
lint brush	66

M

M4 x 8 mm SBHCS	21
M6 shoulder bolt	8
M6 x 16 sbhcs	15
M6 x 20 mm SBHCS	8
machine dimensions	iv
machine layout	v
machine settings	39
machine specifications	iv
maintaining the machine	64
manual sewing mode	46
measurements	57
metric	40

N

needle	70, 91
needle diagram	92
needle groove	92
needle magnet	70
needle plate	77
needle scarf	92
needle size	91

O

oil bottle	65, 66
oiling	65, 66

P

parts	ix
parts of machine	v
power cable	24
power cable retainer	24
power port	vii, 24
power switch	vii, 24
precise sewing mode	42
processed threads	94
pull up bobbin thread	62

R

run time	59
----------	----

S

safety instructions	i
SBHCS screw M5 x 16 mm	19
SBHCS screw M6 x 14 mm	14, 21
screen installation	19
screen settings	50
screwdriver	77, 83, 86
settings menu	39
sewing mode: basting	48
sewing mode: cruise	44
sewing mode: manual	46
sewing mode: precise	42
single-wheel bottom carriage	4
specifications	iv
stitch count	59
stitches per centimeter	40
stitches per inch	40
support	97

T

thread	26, 93
thread cutter (bobbin thread)	27
thread cutter (top thread)	35
thread size	94
thread stand	21, 27, 33
thread strength	31
thread tension	30, 54
thread the machine	31
tie-off	63
timing machine	86
timing spacer	86
tools	ix
track run time	59
track stitch count	59
troubleshooting guide	97

U

units	40
USB connector port	vii

W

wheel alignment	10
wheel base	8
wheel covers	14
wheels	8
winding a bobbin	26

Y

yank test	31
-----------	----



The Grace Company
Phone: 1-800-264-0644
www.graceframe.com

