

Gracie King/Queen Frame

Task 5: Tension the Long Belt

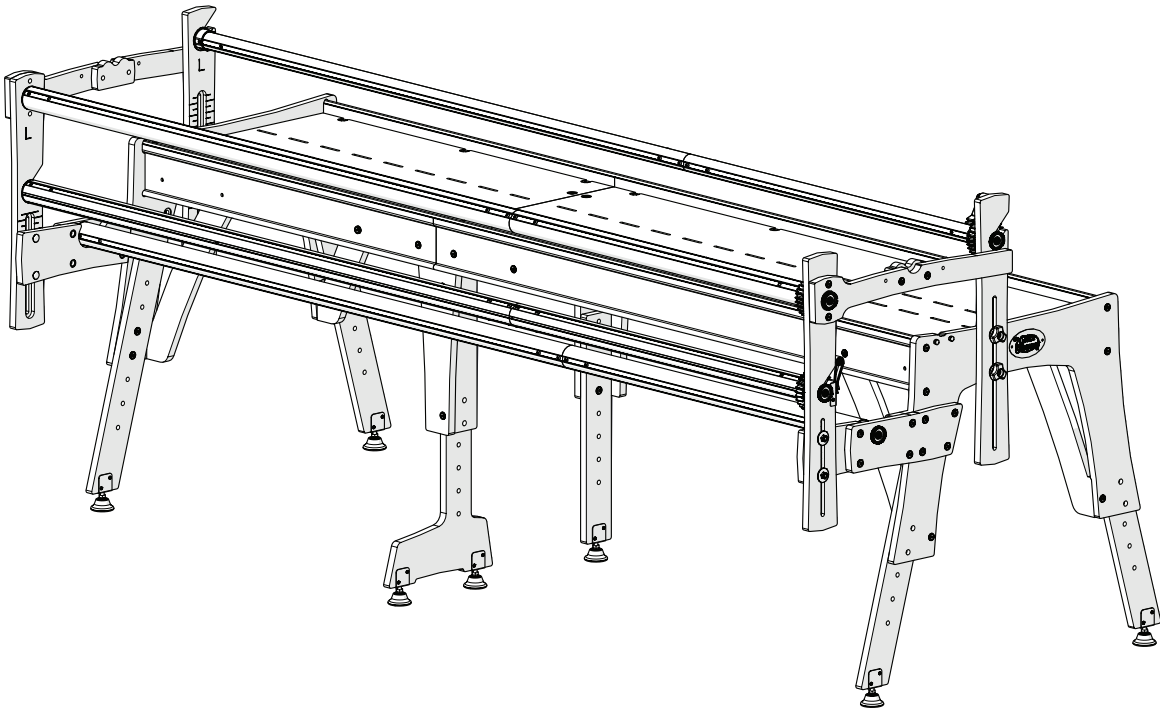

Task 5: Tension the Long Belt

Parts & Tools Needed:

Belt Tensioner

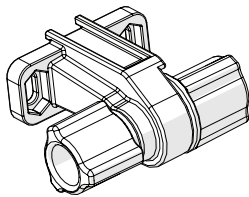

Back Belt Clamp

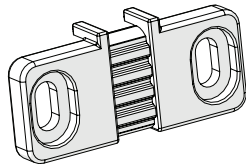

Front Belt Clamp

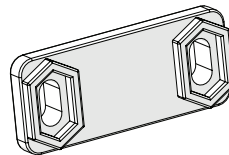

Hex Bolt
M6 x 55 mm (x4)

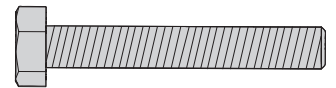

Hex Nut M6 (x2)

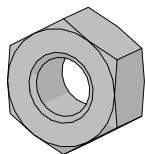

Open-end Wrench
10 mm & 13 mm

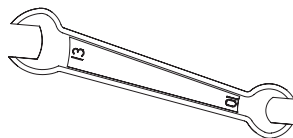

T- Handle
Allen Wrench 4 mm

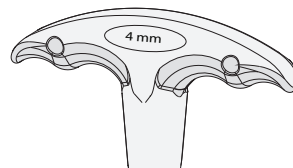

Instructions

The long belt allows QuiltMotion to move horizontally across the frame. Take the following steps to tension the long belt across the frame:

- 1 Place the tensioner on the right side of the frame so the **curve** points down. Attach with the two **M6 x 30 mm hex bolts**.

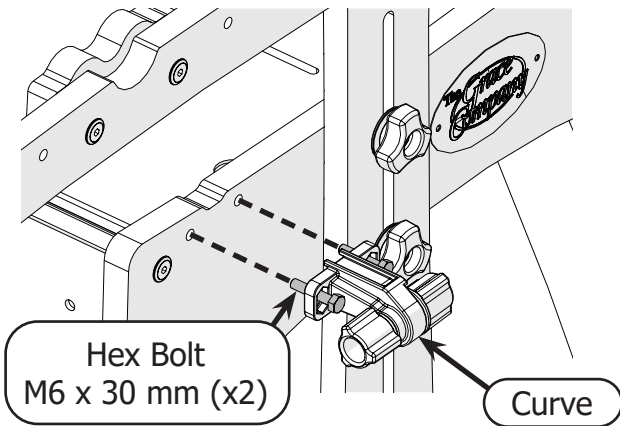

- 2 Slide the two **M6 hex nuts** on the ends of the two M6 x 30 hex bolts. Tighten with the 10 mm open-end wrench.

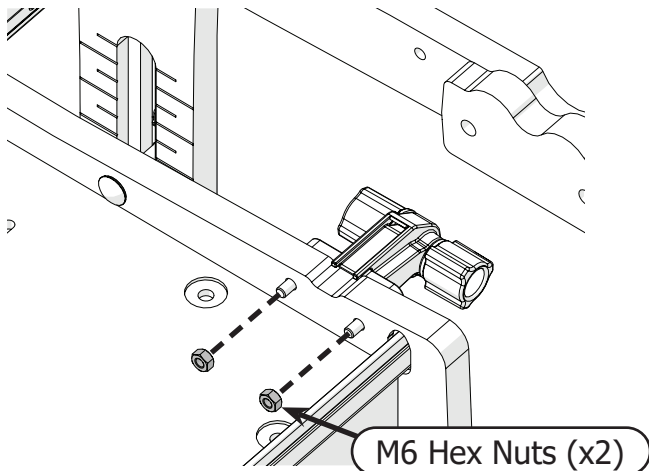

- 3 Place the bottom carriage on its right side on the frame. Do not align with the wheels with the tracks at this time.

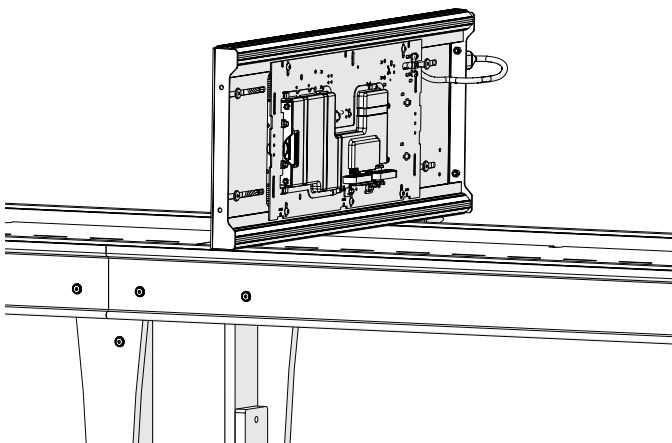

- 4 Cut the **tape** that is holding the long belt coils together.

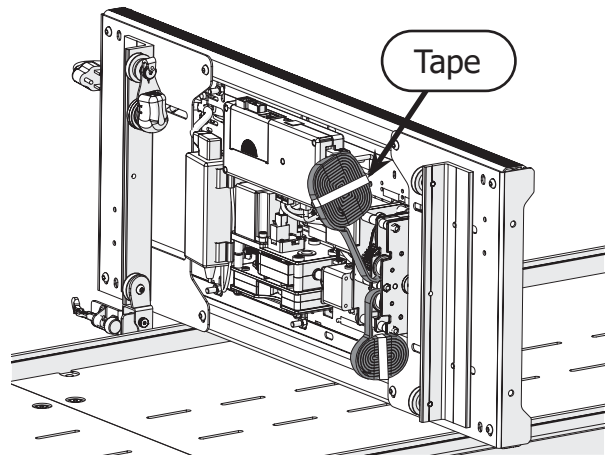

- 5 Lay the carriage flat with the wheels on the tracks and finish unrolling the long belt.

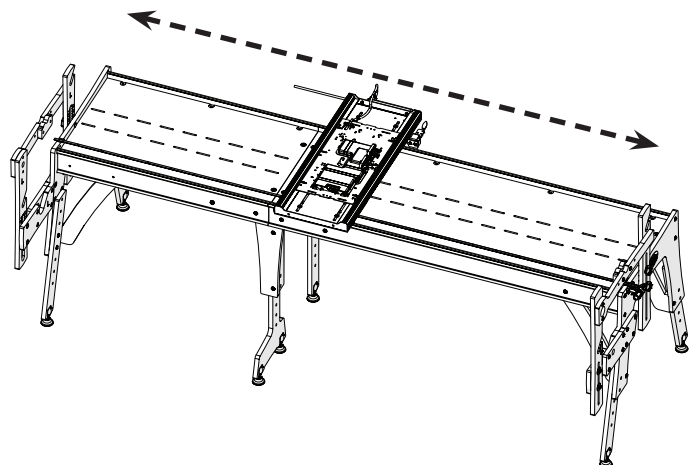
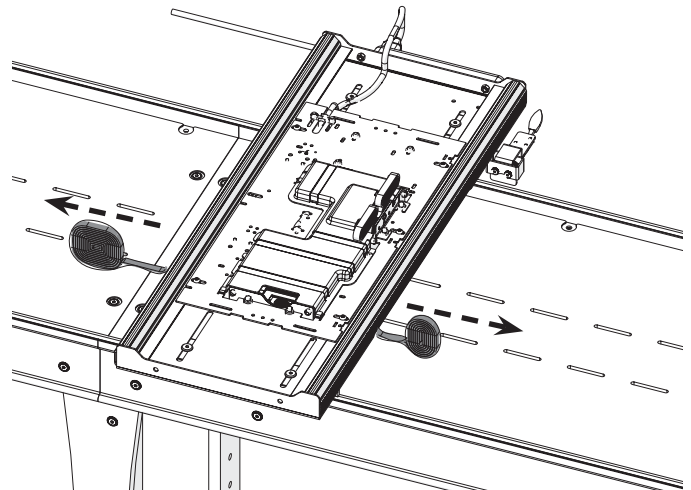

- 6 Place the back belt clamp on the left side of the frame so that the holes align with the holes in the frame.

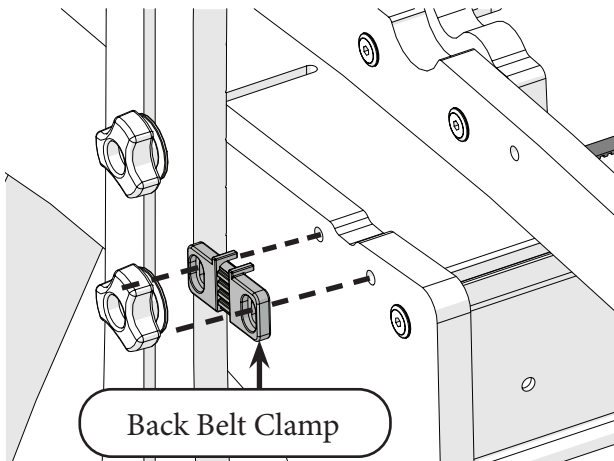

- 7 Drape the **long belt** over the back belt clamp past the bottom of the clamp. Use two **M6 x 40 mm Hex Bolts** to attach the **front belt clamp**.

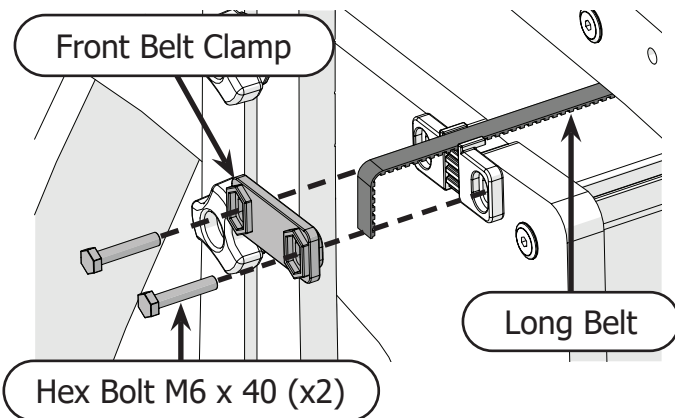

- 8 Fasten the clamp in place using two **M6 hex nuts** and the 10 mm open-end wrench.

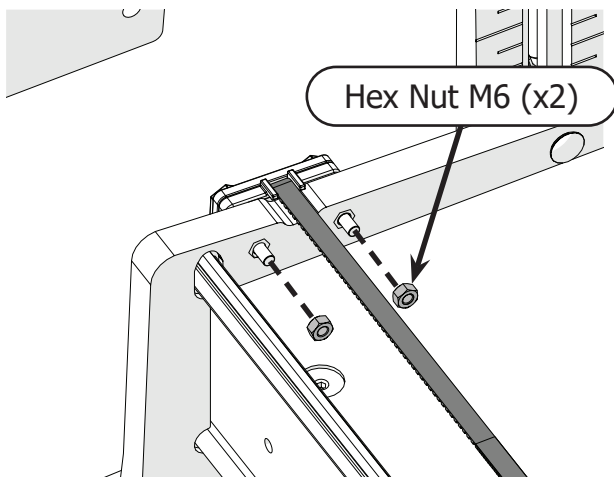

- 9 Feed the other end of the long belt into the top of the **belt tensioner** on the right side of the frame.

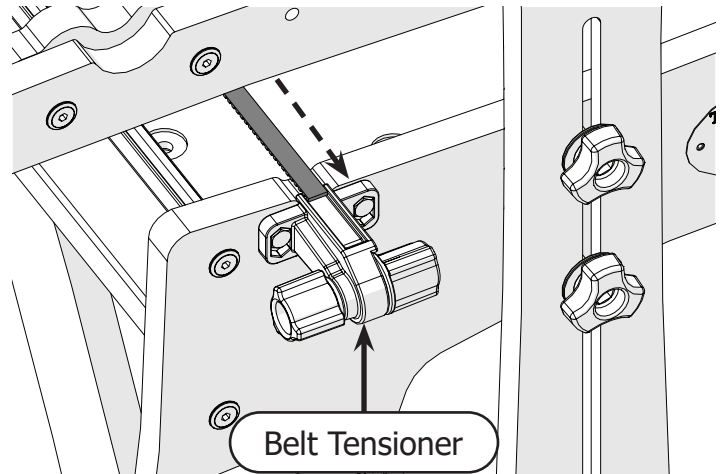

- 10 Turn the **ratchet knob** to pull the extra belt length through the tensioner until the belt is tight across the frame. Turn the **locking knob** to lock it in place.

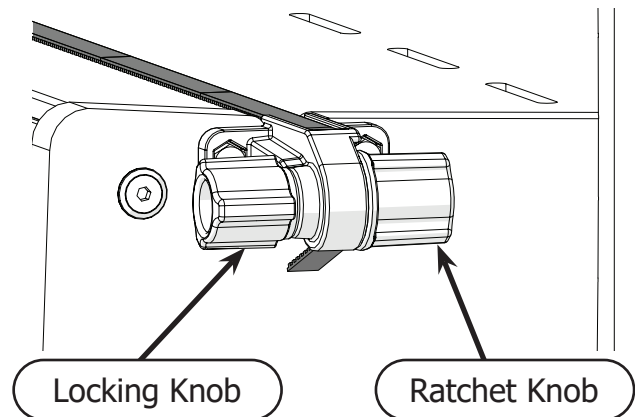

- 11 Once the belt is tight, slide the bottom carriage across the frame. Watch the belt closely for any bowing.

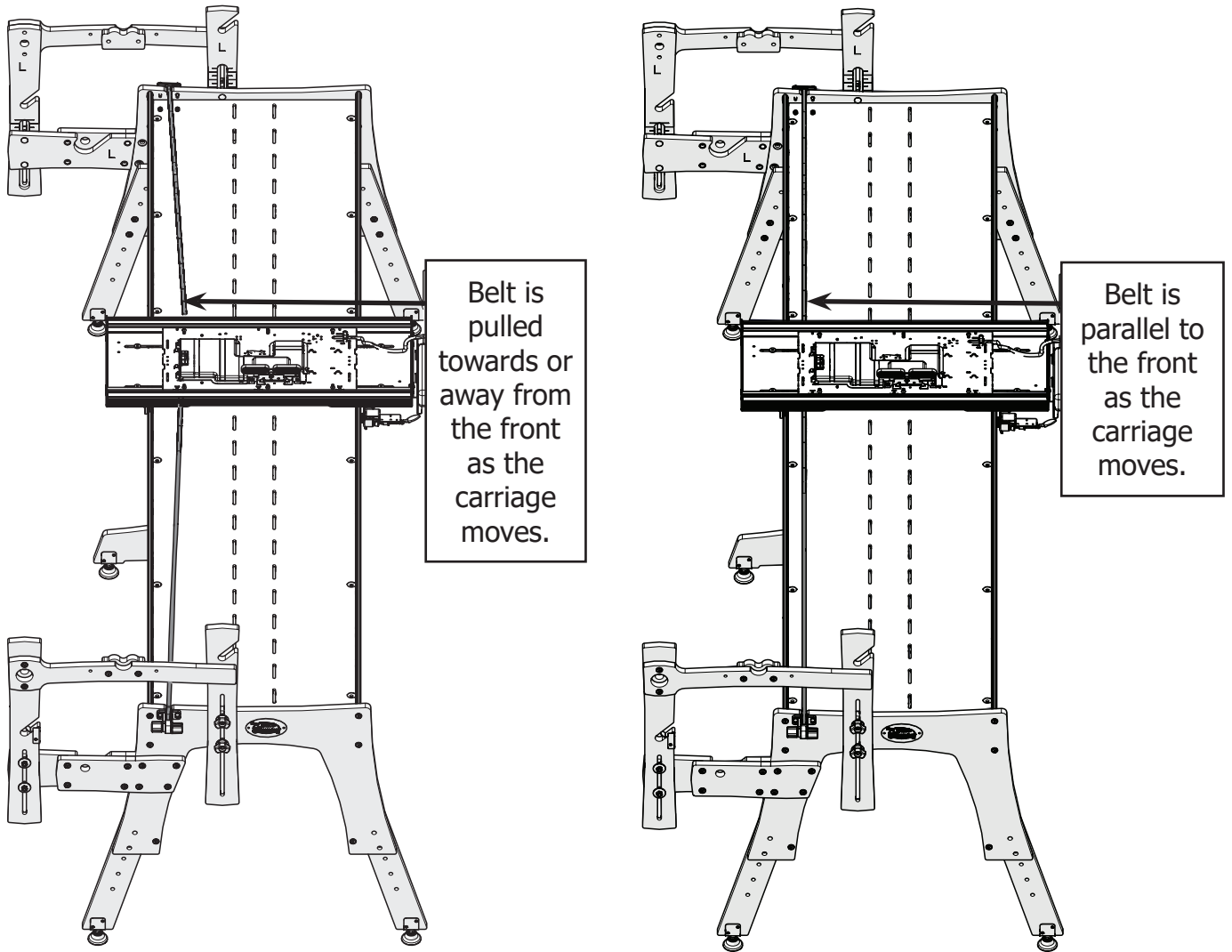

- 12 If the belt is bowing, use the 4 mm Allen wrench to loosen the **shoulder screws** that attach the wheel bases to the carriage. Adjust the carriage on the wheel bases until the belt is straight and then re tighten the shoulder screws.

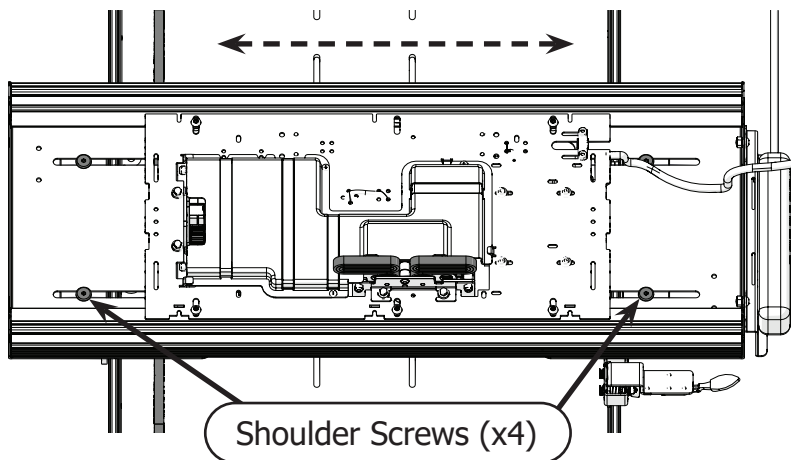

Congratulations! You have completed Part One of this manual.

If you're setting up QuiltMotion on a quilting machine that is not yet assembled:

- Complete the steps in Part Two of your machine's instruction manual.
- If your machine manual is not broken into parts, follow the directions to install and align the machine wheels. Then continue onto Part Two of your QuiltMotion manual.

If you are installing QuiltMotion with a fully assembled quilting machine or a domestic sewing machine on a fully assembled top plate, continue to Part Two of your QuiltMotion manual.

If you will be using a domestic sewing machine and you have not yet assembled your top plate, do so now. Then continue onto Part Two of your QuiltMotion manual.